

Theoretical and experimental results for the
dynamic response of pressure measuring systems.

by

H.Bergh and H.Tijdeman

Summary

For a series-connection of N thin tubes and N volumes a general recursion formula has been derived that relates the sinusoidal pressure disturbance in volume j to the pressure disturbances in the preceding volume $j-1$ and the next volume $j+1$. From this recursion formula the expressions for the complex ratio of the pressure fluctuation of each volume j to the sinusoidal input pressure p_0 can be derived by successively putting $j = N, N - 1, \dots, 2, 1$. For a single pressure measuring system ($N = 1$) and a double pressure measuring system ($N = 2$) these dynamic response formulae are given explicitly.

Theoretical results for single pressure measuring systems are presented that demonstrate the influence of the different parameters. As an illustrative example of the double pressure measuring system some calculations have been performed for a system with a discontinuity in tube radius.

Comparison of theoretical and experimental results shows that the response characteristics of the pressure measuring systems considered can be predicted theoretically to a high degree of accuracy.

Contents.

	<u>Page nr.</u>
<u>1</u> Introduction	5
<u>2</u> Theoretical investigation.	6
<u>2.1</u> General solution.	6
<u>2.2</u> Series connection of N circular tubes and N volumes.	7
<u>2.3</u> Single pressure measuring system.	8
<u>2.4</u> Double pressure measuring system.	9
<u>3</u> Theoretical results.	10
<u>3.1</u> Calculations.	10
<u>3.2</u> Discussions of theoretical results.	10
<u>4</u> Experimental investigation.	12
<u>4.1</u> Test program.	12
<u>4.2</u> Determination of tube radius and pressure transducer volume.	12
<u>4.3</u> Measuring technique.	13
<u>5</u> Experimental results and comparison with theory.	13
<u>6</u> Conclusions.	14
<u>7</u> References.	14

Appendix (9 pages)

4 tables

28 figures

List of symbols.

$a_o = \sqrt{\frac{\gamma p_s}{\rho_s}}$	mean velocity of sound
C_p	specific heat at constant pressure
C_v	specific heat at constant volume
g	gravity constant
$i = \sqrt{-1}$	imaginary unit
J_n	Bessel function of first kind of order n
k	polytropic constant for the volumes
L	tube length
m	mass flow
n	kind of polytropic constant given in eq(1)
N	number of tubes and volumes
$\bar{p} = p_s + p e^{i\omega t}$	total pressure
p_o	amplitude of sinusoidal input pressure
p_s	mean pressure
p	amplitude of pressure disturbance
$Pr = \frac{\mu g C_p}{\lambda}$	Prandtl number
r	co-ordinate in radial direction (fig.1)
R	tube radius
R_e	effective tube radius
R_m	mean tube radius
R_o	gas constant
t	time
$\bar{T} = T_s + T e^{i\omega t}$	total temperature
T_s	mean temperature
T	amplitude of temperature disturbance

$$\bar{u} = u e^{i\gamma t}$$

velocity component in axial direction

$$\bar{v} = v e^{i\gamma t}$$

velocity component in radial direction

$$V_v$$

pressure transducer volume

$$V_t = \pi R^2 L$$

tube volume

$$Y_n$$

Neumann function of first kind of order n

$$x$$

co-ordinate in axial direction (fig.1)

$$\alpha = i^{3/2} R \sqrt{\frac{\rho_s \nu}{\mu}}$$

shear wave number

$$\gamma = \frac{C_p}{C_v}$$

specific heat ratio

$$\lambda$$

thermal conductivity

$$\mu$$

absolute fluid viscosity

$$\nu$$

frequency

$$\bar{\rho} = \rho_s + \rho e^{i\gamma t}$$

fluid density

$$\rho_s$$

mean density

$$\rho$$

amplitude of density disturbance

$$G$$

dimensionless increase in transducer volume due to diaphragm deflection

$$\phi = \frac{\nu}{a_0} \sqrt{\frac{J_0 \langle \alpha \rangle}{J_2 \langle \alpha \rangle}} \sqrt{\frac{\gamma}{n}}$$

subscripts:

$$j$$

refers to pressure transducer j or tube j

$$v$$

pressure transducer volume

1 Introduction.

To support the development at the NLR of a technique for measuring pressure distributions on oscillating windtunnel models (ref.1) a better knowledge of the pressure propagation through thin circular tubes with connected volumes was needed.

The response of pressure measuring systems to a sinusoidal input pressure has been considered by several authors. The method of Taback (ref.2) is based on the analogy between the propagation of sinusoidal disturbances in electrical transmission lines and pressure measuring systems. To predict the response of a pressure measuring system, he uses the propagation velocity calculated from the Rayleigh formula combined with measured values of the attenuation. The fact that the attenuation constants have to be determined experimentally is one of the main disadvantages of this method.

In ref.3 Davis presents asymptotic forms of the dynamic response formulae that can be used as basic guides for the selection of a pressure measuring system. In his work also some comparisons with experimental results are given. Iberall (ref.4) derives the formulae for the dynamic response from the fundamental flow equations, i.e. the Navier-Stokes equations, the equation of continuity, the equation of state and the energy equation. The analytical part of his derivation has been omitted and no comparison with experimental values has been made.

Proceeding along the same lines as Iberall, the present report gives the derivation of a general recursion formula for the dynamic response of a series connection of N tubes and N volumes (fig.2).

From this recursion formula the expressions for the dynamic response of a single pressure measuring system ($N = 1$, fig.3) and a double pressure measuring system ($N = 2$, fig.4) are obtained and presented explicitly. The importance of the various parameters is illustrated by numerical examples representative for applications of the mentioned measuring technique.

The reliability of the theoretical predictions has been verified by comparing calculated and experimental results for single pressure measuring systems with different tube lengths and radii and for a system with one discontinuity in tube diameter.

The authors wish to express their thanks to mr. A.C.A. Bosschaart for his valuable contribution in the earlier stage of this investigation.

2 Theoretical investigation.

2.1 General solution.

The motion of the fluid in a tube with a circular cross-section can be described by the fundamental flow equations, i.e., the Navier-Stokes equations, the equation of continuity, the equation of state and the energy equation that gives the balance between thermal and kinetic energies (see appendix).

As only the behaviour of sinusoidal oscillations in a fluid without steady velocity component are considered it can be assumed that:

$$\bar{p} = p_s + p e^{i\omega t}, \quad \bar{\rho} = \rho_s + \rho e^{i\omega t}, \quad \bar{T} = T_s + T e^{i\omega t}, \quad \bar{u} = u e^{i\omega t} \quad \text{and} \quad \bar{v} = v e^{i\omega t}.$$

where u and v are the oscillatory axial and radial velocity components respectively.

Furthermore assuming that:

- the sinusoidal disturbances are very small
- the internal radius of the tube is small in comparison with its length
- the flow is laminar throughout the system

the mentioned equations can be simplified considerably.

To solve the unknown quantities p, ρ, T, u and v the following boundary conditions have been prescribed. At the rigid wall of the tube the velocity components u and v must be zero. Due to the axial-symmetry of the problem the velocity component v must be also zero at the centerline of the tube. At the wall T has been taken zero, supposing the heat conductivity of the wall being so large that the temperature variations at the wall disappear.

The latter condition, that gives a good representation of what happens in reality, has the advantage that it is not necessary to study in detail the heat exchange between the fluid within the tube, the tubewall and the environment.

For a tube of finite length the solution of the linearized flow equations, that satisfies the former boundary conditions has been given in the appendix.

The two remaining constants can be determined by specifying the boundary conditions at both ends of the tube. That means that at the entrance of tube j the pressure variation must be equal to the given pressure disturbance $p_{j-1} e^{i\omega t}$, while at the end of the tube, where the volume j is connected, the increase of mass of the pressure transducer must be equal to the difference in mass flow leaving tube j and the mass flow entering tube $j + 1$.

To describe the physical process within the transducer volume it is assumed that the pressure and density are only time dependent within this volume and that the pressure expansion takes place polytropically.

The transducer volume has been defined by $V_j (1 + \sigma_j \frac{p_j}{p_s} e^{i\nu t})$, where σ_j is a dimensionless factor giving the increase in volume due to diaphragm deflection. This formulation is valid if the resonance frequency of the diaphragm is large in comparison with the frequency ν of the pressure fluctuation.

2.2 Series connection of N circular tubes and N volumes.

For a series connection of N tubes and N volumes (see fig.2) a recursion formula has been derived that relates the sinusoidal pressure disturbance in volume j to the sinusoidal pressure disturbances in the preceding volume j-1 and the next volume j+1.

The derivation of this formula is given in the appendix. The result is:

$$\frac{p_j}{p_{j-1}} = \left[\cosh \langle \phi_j L_j \rangle + \frac{V_j}{V_{t_j}} \left(\sigma_j + \frac{1}{k_j} \right) n_j \phi_j L_j \frac{\sinh \langle \phi_j L_j \rangle}{\sinh \langle \phi_{j+1} L_{j+1} \rangle} + \frac{V_{t_{j+1}} \phi_{j+1} L_j J_0 \langle \alpha_j \rangle J_2 \langle \alpha_{j+1} \rangle}{V_{t_j} \phi_j L_{j+1} J_0 \langle \alpha_{j+1} \rangle J_2 \langle \alpha_j \rangle} \frac{\sinh \langle \phi_j L_j \rangle}{\sinh \langle \phi_{j+1} L_{j+1} \rangle} \right] \left[\cosh \langle \phi_{j+1} L_{j+1} \rangle - \frac{p_{j+1}}{p_j} \right]^{-1} \quad (1)$$

$$\text{with } \phi_j = \frac{\nu}{a_{o_j}} \sqrt{\frac{J_0 \langle \alpha_j \rangle}{J_2 \langle \alpha_j \rangle}} \sqrt{\frac{\gamma}{n_j}}$$

$$\alpha_j = i \sqrt{i} R_j \sqrt{\frac{\rho_s \nu}{\mu_j}}, \text{ the so-called shear wave number, being a measure of the wall shearing effects.}$$

$$n_j = \left[1 + \frac{\gamma-1}{\gamma} \frac{J_2 \langle \alpha_j \rangle \sqrt{P_r}}{J_0 \langle \alpha_j \rangle \sqrt{P_r}} \right]^{-1}$$

From formula (1) the expressions for the complex ratio of the pressure fluctuation in each transducer j to the sinusoidal input pressure p_0 can be derived by successively putting $j = N, N-1, \dots, 2, 1$.

It appears that a solution identical to (1) is obtained if the equation of state and the energy equation are replaced by the polytropic relation

$$\frac{\bar{p}}{\bar{p}^n} = \text{constant, with } n = \left[1 + \frac{\gamma-1}{\gamma} \frac{J_2 \langle \alpha_j \sqrt{P_r} \rangle}{J_0 \langle \alpha_j \sqrt{P_r} \rangle} \right]^{-1}$$

Evidently the pressure expansion in tube j can be interpreted as a polytropic process with a polytropic factor

$$n_j = \left[1 + \frac{\gamma-1}{\gamma} \frac{J_2 \langle \alpha_j \sqrt{P_r} \rangle}{J_0 \langle \alpha_j \sqrt{P_r} \rangle} \right]^{-1}$$

Asymptotic values are $\lim_{\alpha_j \rightarrow 0} n_j = 1$ and $\lim_{\alpha_j \rightarrow \infty} n_j = \gamma$, corresponding to

isothermal and isentropic conditions respectively. In fig.6 the factor n is given as a function of the parameter $\alpha \sqrt{P_r}$.

It will be remarked that by putting $V_{v_j} = 0$ expression (1) offers the possibility for calculating the dynamic response for a system with a discontinuity in tube radius or in temperature.

2.3 Single pressure measuring system (fig.3)

The formula for the dynamic response to a sinusoidal pressure input p_0 of a system consisting of one tube connected at the end to the instrument volume V_v can be derived immediately from the general recursion formula by putting $j = N = 1$.

The result yields:

$$\frac{p_1}{p_0} = \left[\cosh \langle \phi L \rangle + \frac{V_v}{V_t} \left(\sigma + \frac{1}{k} \right) n \phi L \sinh \langle \phi L \rangle \right]^{-1} \quad (2)$$

It can be shown easily that the expression (2) is identical to that derived by Iberall (ref.4) for the complex attenuation of the fundamental.

In the case of an inviscid isentropically expanding fluid in the tube ($\mu = 0$; $n = \gamma$)

$\sqrt{\frac{J_0 < \alpha >}{J_2 < \alpha >}} \rightarrow 1$ and the formula for the pressure ratio becomes

$$\frac{p_1}{p_0} = \left[\cos \left\langle \frac{vL}{a_0} \right\rangle - \gamma \frac{v}{v_t} \left(\sigma + \frac{1}{k} \right) \frac{vL}{a_0} \sin \left\langle \frac{vL}{a_0} \right\rangle \right]^{-1} \quad (3)$$

From eq(3) it follows that resonance will occur if

$$\cotg \left\langle \frac{vL}{a_0} \right\rangle = \gamma \frac{v}{v_t} \left(\sigma + \frac{1}{k} \right) \frac{vL}{a_0} \quad (4)$$

In the limiting cases $v_v = 0$ and $v_v = \infty$ eq(4) yields the well known organ pipe resonance formulae for a closed and open organ pipe.

$$\left. \begin{aligned} v_v = 0: \quad \cotg \left\langle \frac{vL}{a_0} \right\rangle = 0, \text{ that means } \frac{v}{2\pi} = \frac{2s+1}{4} \frac{a_0}{L} \quad (s = 0, 1, 2, \dots) \\ v_v = \infty: \quad \cotg \left\langle \frac{vL}{a_0} \right\rangle = \infty, \text{ that means } \frac{v}{2\pi} = \frac{s}{2} \frac{a_0}{L} \quad (s = 1, 2, \dots) \end{aligned} \right\} \quad (5)$$

2.4 Double pressure measuring system (fig.4).

Using the recursion formula (1) for the system formed by a series connection of two systems as treated above the following formulae for the dynamic response of this system are obtained:

$$j = 2: \quad \frac{p_2}{p_1} = \left[\cosh \langle \phi_2 L_2 \rangle + n_2 \frac{v_2}{v_{t_2}} \left(\sigma_2 + \frac{1}{k_2} \right) \phi_2 L_2 \sinh \langle \phi_2 L_2 \rangle \right]^{-1} \quad (6)$$

$$j = 1: \quad \frac{p_1}{p_0} = \left[\cosh \langle \phi_1 L_1 \rangle + n_1 \frac{v_1}{v_{t_1}} \left(\sigma_1 + \frac{1}{k_1} \right) \phi_1 L_1 \sinh \langle \phi_1 L_1 \rangle + \frac{v_{t_2} \phi_2 L_1 J_0 \langle \alpha_1 \rangle J_2 \langle \alpha_2 \rangle}{v_{t_1} \phi_1 L_2 J_0 \langle \alpha_2 \rangle J_2 \langle \alpha_1 \rangle} \frac{\sinh \langle \phi_1 L_1 \rangle}{\sinh \langle \phi_2 L_2 \rangle} \left\{ \cosh \langle \phi_2 L_2 \rangle - \frac{p_2}{p_1} \right\} \right]^{-1} \quad (7)$$

The complex pressure ratio $\frac{p_2}{p_0} = \frac{p_2}{p_1} \cdot \frac{p_1}{p_0}$ can be found from eq (6) and (7)

3 Theoretical results.

3.1 Calculations.

Besides calculations for comparison with experimental results (see section 5) a number of specific cases has been calculated to show the influence of different parameters on the dynamic response of a pressure measuring system. From the theoretical expressions it can be seen that the dynamic response depends on the following parameters:

geometric parameters:

R = tube radius

L = tube length

V_v = pressure transducer volume

σ = dimensionless increase in transducer volume
due to diaphragm deflection

physical parameters:

k = polytropic constant for the pressure expansion
in the transducer volume

T_s = mean temperature

p_s = mean pressure

It must be noted that the quantities V_v , σ and k only appear in the combination $V_v (\sigma + \frac{1}{k})$; a variation in one of these parameters separately can be expressed as an equivalent variation in one of the others.

The cases given in table 1 have been calculated to demonstrate the influence of the mentioned parameters on the dynamic response of the single pressure measuring system of fig.3.

As an example of a double pressure measuring system, the dynamic response has been calculated for a system with a discontinuity in tube radius (fig.5). The different cases that have been considered for this system are summarized in table 2.

3.2 Discussion of theoretical results.

a Influence of the different parameters:

The results of fig.9,10 and 11 show that in most cases, just like in organ pipes, resonance peaks occur. As could be expected it appears that for a given length a wider tube produces higher resonance peaks than a smaller one. Lengthening a tube of a given diameter results in lower resonance peaks at smaller values of the frequency. Furthermore for certain combinations of L and R

no resonances occur as is demonstrated in fig.11 for $R = 0,50$ mm. From fig.12 it can be seen that the product $V_v \left(\bar{G} + \frac{1}{k} \right)$ must be changed considerably to have much effect on the dynamic response characteristic. Mostly the increase in pressure transducer volume due to the deflection of the diaphragm is only a very small part of the total volume. The influence of the factor \bar{G} itself therefore will be very small. The extreme values of the factor k are 1 and 1,4, corresponding respectively to isothermal and isentropic pressure expansion in the instrument volume. Fig.13 shows that this factor only has a small influence on the response characteristic.

The variations of the mean pressure p_g that have been considered appear to have a strong influence on the dynamic response of a pressure measuring system (fig.14). A variation in mean temperature between 0° and 30° C does not have much effect (see fig.15).

b System with discontinuity in tube radius.

The results for the given systems with a discontinuity in tube radius show some remarkable facts. From fig.16, 17 and 18 it can be seen that a wider second tube does not always have a favourable effect on the dynamic response. A smaller second tube on the contrary does not always act unfavourable.

This can be explained as follows: For a system consisting of a smaller tube followed by a wider one, the latter tube is more easy to overcome for a pressure disturbance due to relatively smaller effect of wall friction. On the other hand the wider tube acts like a kind of additional volume, thus reducing the output of the first tube. This two opposite effects are responsible for the final behaviour of the total system. The same effects, but working in opposite sense, are responsible for the behaviour of a system of a wider tube followed by a smaller one.

It will be clear that by changing the lengths of the two connected tubes also the ratio of the mentioned effects will be changed, thus giving other response characteristics.

From fig.19 and 20 it follows that a restriction at the entrance of a tube generally results in lower values of the amplitude ratio than in the case of a restriction at the end of the tube. Also in these figures it can be seen that changing the lengths of the restrictions gives other response characteristics. By proper selection of the ratio of tube lengths and of the ratio of tube diameters, a response characteristic can be obtained which is most suitable for a given purpose. In practice however one must be careful, because the discontinuities in the tube offer the possibility of non-linearities.

4 Experimental investigation.

4.1 Test program.

To get an insight into the reliability of the theoretical formulae an experimental investigation has been performed for a series of tubes of various dimensions (see table 3 and 4). Except the two longer tubes, which are of plastic, all the tubes are made of stainless steel. With the aid of the equipment described in section 4.3 the dynamic responses have been measured in the frequency range $10 \leq \nu \leq 200$ c.p.s. At the entrance of the systems a sinusoidal pressure disturbance of about 65 kg/m^2 has been applied. To investigate the linearity of the systems with a discontinuity in tube radius two values of the input pressure p_0 have been used.

4.2 Determination of tube radius and pressure transducer volume.

The dynamic response of a pressure measuring system is very sensitive to small variations in tube radius. This implies that it is necessary to have an accurate method for determining that internal radius of the thin tubes. In the present investigation the mean tube radius R_m is determined as follows:

- 1) by weighing the tube empty and measuring the mean external diameter. From the tube weight, the specific weight of the tube material and the external diameter the mean wall-thickness can be calculated.
- 2) by weighing the tube empty and filled with water. The mean radius R_m than can be calculated from the increase in weight.

	tube length	R_m (method 1)	R_m (method 2)	R_m (used in calculations)
Results:	500 mm	0,519 mm	0,529 mm	0,525 mm
	1000	0,490	0,492	0,49
	1000	0,792	0,799	0,795
	1000	1,092	1,092	1,09
	3000	-	0,70	0,70
	3910	-	0,965	0,965

To determine the volumes of the pressure transducers the test set up of fig.7 has been used. A variation of p_1 results in a variation of p_2 and thus in a variation of the volume of the instrument plus connecting glass tube of known diameter. From the displacement of mercury drop 2 the value of G can be determined. From the displacement of drop 1 the value of V_v can be calculated with the aid of Boyle's law.

4.3 Measuring technique.

The semi-automatic measuring system, which has been developed at the NLR to enable a quick determination of a large number of pressures on oscillating windtunnel models (ref.1) has been used to perform the present experiments. A block-diagram of the equipment is drawn in fig.8. In the electro-dynamically driven pressure generator a harmonically varying pressure with amplitude p_0 and frequency ν is generated. The signals of the pressure transducers 1 and 2 are amplified one after the other and fed into the vector component resolver, that decomposes them into one component in phase with the 0-degree oscillator signal and one in quadrature to it. The resolver rejects all signals, except those, having a frequency equal to that of the oscillator. The two components of each signal are measured by a digital voltmeter.

The results P_2/P_1 have been corrected for the attenuation of the small tube, that connects transducer 1 to the internal volume of the pressure generator. In the frequency range considered this correction is only of the order of a few percent.

5 Experimental results and comparison with theory.

The experimental and theoretical results for a single pressure measuring system with different tube lengths and tube radii have been plotted in the figs. 21-26. In fig.27 and 28 the results for the system with a discontinuity in tube radius are presented.

The theoretical results have been calculated assuming an ideal tube with circular cross section and constant internal radius. In reality an exact measurement of the tube radius is not possible and furthermore local deviations may occur. A comparison of the experimental results with theoretical results calculated with the experimentally determined mean tube radius R_m shows that in most cases small deviations exist. It appears that these differences can be completely cancelled by performing the calculations with an effective tube radius R_e which is only slightly (2-5 %) smaller than the mean radius R_m . The fact that the largest correction must be applied to the smallest tube seems to indicate that the determination of the mean tube radius was not accurate enough. This is supported by the two experiments with the discontinuous system (fig.27 and 28).

In the first case the pressure disturbance has been applied at the entrance of the wider part of the tube and the pressure transducer was connect-

ed to the end of the smaller one. In the second case the same tube has been used, but now in opposite direction. In both cases the same effective radii for the two parts must be taken to obtain theoretical results that are in perfect agreement with experiment. Furthermore it is striking that these values agree with the effective radii of the tubes of the single systems of fig.21 and 23, that are coming from the same original tubes as the two parts of the discontinuous system. The results with different values of the pressure input p_0 show that in the range considered non linear effects are hardly present.

Finally, since both steel tubes and plastic tubes give a good agreement between theory and experiment, the tube material appears to have no noticeable influence.

6 Conclusions.

From the investigation, the following conclusions can be drawn:

- 1) The response characteristics of the pressure measuring systems considered can be predicted theoretically to a high degree of accuracy.
- 2) In the range of applied sinusoidal input pressures the non-linearities are negligible.
- 3) The tube material does not have any noticeable influence on the dynamic response.
- 4) The present theory enables the optimal design of pressure measuring systems adapted to the NLR technique for measuring pressure distributions on oscillating windtunnelmodels.

7 References.

- 1 Bergh, H. A new method for measuring the pressure distribution on harmonically oscillating wings.
Proceedings of the 4th FICAS-congress, Paris 1964
(also NLR-MP.224)
- 2 Taback, I. The response of pressure measuring systems to oscillating pressures.
NACA TN 1819, 1949

- 3 Davis jr., E.L. The measurement of unsteady pressures in windtunnels
AGARD rep. 169; 1958.
- 4 Iberall, A.S. Attenuation of oscillatory pressures in instrument
lines.
Journal of research of the national bureau of
standards.
Vol.45, July 1950.

APPENDIX.

DERIVATION OF THE FORMULAE.

The equations governing the motion of a fluid in a circular tube (fig.1) are:

- (a) The NAVIER-STOKES equations (for constant value of the absolute fluid viscosity μ):

$$\bar{\rho} \frac{\partial \bar{u}}{\partial t} + \bar{v} \frac{\partial \bar{u}}{\partial r} + \bar{u} \frac{\partial \bar{u}}{\partial x} = - \frac{\partial \bar{p}}{\partial x} + \mu \left[\frac{\partial^2 \bar{u}}{\partial x^2} + \frac{\partial^2 \bar{u}}{\partial r^2} + \frac{1}{r} \frac{\partial \bar{u}}{\partial r} \right] + \frac{1}{3} \frac{\partial}{\partial x} \left[\frac{\partial \bar{u}}{\partial x} + \frac{\partial \bar{v}}{\partial r} + \frac{\bar{v}}{r} \right] \quad (1)$$

$$\bar{\rho} \frac{\partial \bar{v}}{\partial t} + \bar{v} \frac{\partial \bar{v}}{\partial r} + \bar{u} \frac{\partial \bar{v}}{\partial x} = - \frac{\partial \bar{p}}{\partial r} + \mu \left[\frac{\partial^2 \bar{v}}{\partial r^2} + \frac{1}{r} \frac{\partial \bar{v}}{\partial r} - \frac{\bar{v}}{r^2} + \frac{\partial^2 \bar{v}}{\partial x^2} \right] + \frac{1}{3} \frac{\partial}{\partial r} \left[\frac{\partial \bar{u}}{\partial x} + \frac{\partial \bar{v}}{\partial r} + \frac{\bar{v}}{r} \right] \quad (2)$$

- (b) The equation of continuity:

$$\frac{\partial \bar{\rho}}{\partial t} + \bar{u} \frac{\partial \bar{\rho}}{\partial x} + \bar{v} \frac{\partial \bar{\rho}}{\partial r} + \bar{\rho} \left[\frac{\partial \bar{u}}{\partial x} + \frac{\partial \bar{v}}{\partial r} + \frac{\bar{v}}{r} \right] = 0 \quad (3)$$

- (c) The equation of state for an ideal gas:

$$\bar{p} = \bar{\rho} R_0 \bar{T} \quad (4)$$

- (d) The energy equation:

$$\bar{\rho} \bar{c}_p \left[\frac{\partial \bar{T}}{\partial t} + \bar{u} \frac{\partial \bar{T}}{\partial x} + \bar{v} \frac{\partial \bar{T}}{\partial r} \right] = \lambda \left[\frac{\partial^2 \bar{T}}{\partial r^2} + \frac{1}{r} \frac{\partial \bar{T}}{\partial r} + \frac{\partial^2 \bar{T}}{\partial x^2} \right] + \frac{\partial \bar{p}}{\partial t} + \bar{u} \frac{\partial \bar{p}}{\partial x} + \bar{v} \frac{\partial \bar{p}}{\partial r} + \mu \phi \quad (5)$$

where ϕ is the dissipation function that represents the heat transfer due to internal friction:

$$\phi = 2 \left[\left(\frac{\partial \bar{u}}{\partial x} \right)^2 + \left(\frac{\partial \bar{v}}{\partial r} \right)^2 + \left(\frac{\bar{v}}{r} \right)^2 \right] + \left[\frac{\partial \bar{v}}{\partial x} + \frac{\partial \bar{u}}{\partial r} \right]^2 - \frac{2}{3} \left[\frac{\partial \bar{u}}{\partial x} + \frac{\partial \bar{v}}{\partial r} + \frac{\bar{v}}{r} \right]^2$$

Putting

$$\left. \begin{aligned} \bar{p} &= p_s + p e^{i\omega t} \\ \bar{\rho} &= \rho_s + \rho e^{i\omega t} \\ \bar{T} &= T_s + T e^{i\omega t} \\ \bar{u} &= u e^{i\omega t} \\ \bar{v} &= v e^{i\omega t} \end{aligned} \right\} \quad (6)$$

and assuming that:

- the sinusoidal disturbances are very small
- the internal radius of the tube is small in comparison with its length
- the flow is laminar throughout the system

the eqs (1) to (5) can be simplified to:

$$i\nu u = - \frac{1}{\rho_s} \frac{\partial p}{\partial x} + \frac{\mu}{\rho_s} \left[\frac{\partial^2 u}{\partial r^2} + \frac{1}{r} \frac{\partial u}{\partial r} \right] \quad (6)$$

$$0 = - \frac{\partial p}{\partial r} \quad (7)$$

$$i\nu \rho = - \rho_s \left[\frac{\partial u}{\partial x} + \frac{\partial v}{\partial r} + \frac{v}{r} \right] \quad (8)$$

$$\rho = \frac{\gamma}{a_o^2} \left(1 + \frac{\rho_s}{T_s} \frac{T}{\rho} \right) \text{ or } \rho = \frac{\gamma}{a_o^2} (p - \rho_s R_o T) \quad (9)$$

$$i\nu \rho_s g C_p T = \lambda \left[\frac{\partial^2 T}{\partial r^2} + \frac{1}{r} \frac{\partial T}{\partial r} \right] + i\nu p. \quad (10)$$

The unknown quantities p, ρ, T, u and v must satisfy the following boundary conditions:

At the wall of the tube ($r = R$):

$$\text{zero radial and axial velocity, i.e.: } u = 0 ; v = 0 \quad (11)$$

$$\text{The conductivity of the wall is supposed to be so large that the variation in temperature at the wall will be zero: } T = 0 \quad (12)$$

At the center of the tube ($r = 0$):

$$\text{Due to the axial-symmetry of the problem: } v = 0 \quad (13)$$

A further requirement is that the values of u, T, p and ρ remain finite

General solution:

From eq.(7) it follows that the amplitude of the pressure disturbance p is a function of the x -coordinate only.

Eq(10) can be written as:

$$T - \frac{\lambda}{i\nu \rho_s g C_p} \left[\frac{\partial^2 T}{\partial r^2} + \frac{1}{r} \frac{\partial T}{\partial r} \right] = \frac{p}{\rho_s g C_p} \quad (14)$$

Introducing the notation $\alpha = i^{3/2} R \sqrt{\frac{\rho_B v}{\mu}}$ and $P_r = \frac{\mu g C_p}{\lambda}$ (the so-called Prandtl-number) and putting $T = f\langle x \rangle h\langle z \rangle$, where $z = \frac{\alpha r}{R} \sqrt{P_r}$, equation (14) reads:

$$\frac{d^2 h\langle z \rangle}{dz^2} + \frac{1}{z} \frac{dh\langle z \rangle}{dz} + h\langle z \rangle = \frac{p}{\rho_s g C_p} \frac{1}{f\langle x \rangle} \quad (15)$$

with the solutions:

$$h\langle z \rangle = C_1 J_0\langle z \rangle + C_2 Y_0\langle z \rangle + \frac{p}{\rho_s g C_p} \frac{1}{f\langle x \rangle} \quad (16)$$

From the condition that T must remain finite for $r = 0$, it follows $C_2 \equiv 0$. For $r = R$ T must be zero, so:

$$f\langle x \rangle = - \frac{1}{C_1 J_0\langle \alpha \sqrt{P_r} \rangle} \frac{p}{\rho_s g C_p} \quad (17)$$

From (16) and (17)

$$T = f\langle x \rangle h\langle z \rangle = \left[1 - \frac{J_0\langle \frac{\alpha r}{R} \sqrt{P_r} \rangle}{J_0\langle \alpha \sqrt{P_r} \rangle} \right] \frac{p}{\rho_s g C_p} \quad (18)$$

and substituting this result in eq (9):

$$\rho = \frac{\gamma}{a_0^2} p \left[1 - \frac{\gamma - 1}{\gamma} \left\{ 1 - \frac{J_0\langle \frac{\alpha r}{R} \sqrt{P_r} \rangle}{J_0\langle \alpha \sqrt{P_r} \rangle} \right\} \right] \quad (19)$$

Eq(6) can be rewritten as:

$$u - \frac{\mu}{i\nu\rho_s} \left[\frac{\partial^2 u}{\partial r^2} + \frac{1}{r} \frac{\partial u}{\partial r} \right] = - \frac{1}{i\nu\rho_s} \frac{dp}{dx} \quad (20)$$

This equation can be solved in a similar way as eq(14). The solution that fulfils the requirements that u remains finite for $r = 0$ and is zero for $r = R$ yields:

$$u = \left[\frac{J_0\langle \frac{\alpha r}{R} \rangle}{J_0\langle \alpha \rangle} - 1 \right] \frac{1}{i\nu\rho_s} \frac{dp}{dx} \quad (21)$$

Finally the equation of continuity, eq (8), has to be satisfied, thus

$$\frac{1}{r} \frac{\partial(v.r)}{\partial r} = i\nu \frac{\rho}{\rho_s} - \frac{\partial u}{\partial x} \quad (22)$$

or with the aid of the expressions (19) and (21):

$$\frac{1}{r} \frac{\partial(v.r)}{\partial r} = \frac{1}{i\nu\rho_s} \left[\frac{\nu^2}{a_o^2} \gamma_p \left\{ 1 - \frac{\gamma-1}{\gamma} \left(1 - \frac{J_o \langle \frac{\alpha r}{R} \sqrt{P_r} \rangle}{J_o \langle \alpha \sqrt{P_r} \rangle} \right) \right\} - \frac{d^2_p}{dx^2} \left\{ \frac{J_o \langle \frac{\alpha r}{R} \rangle}{J_o \langle \alpha \rangle} - 1 \right\} \right] \quad (23)$$

After integration with respect to r:

$$v.r = \frac{1}{i\nu\rho_s} \left[\frac{\nu^2}{a_o^2} \gamma_p \left\{ \frac{1}{2} r^2 - \frac{\gamma-1}{\gamma} \left(\frac{1}{2} r^2 - \frac{rR}{\alpha \sqrt{P_r}} \frac{J_1 \langle \frac{\alpha r}{R} \sqrt{P_r} \rangle}{J_o \langle \alpha \sqrt{P_r} \rangle} \right) \right\} - \frac{d^2_p}{dx^2} \left\{ \frac{rR}{\alpha} \frac{J_1 \langle \frac{\alpha r}{R} \rangle}{J_o \langle \alpha \rangle} - \frac{1}{2} r^2 \right\} + F \langle x \rangle \right] \quad (24)$$

From the boundary condition $v = 0$ for $r = R$ it follows:

$$- F \langle x \rangle = \frac{\nu^2}{a_o^2} \gamma \frac{R^2}{2} p \left\{ 1 + \frac{\gamma-1}{\gamma} \frac{J_2 \langle \alpha \sqrt{P_r} \rangle}{J_o \langle \alpha \sqrt{P_r} \rangle} \right\} - \frac{R^2}{2} \frac{d^2_p}{dx^2} \frac{J_2 \langle \alpha \rangle}{J_o \langle \alpha \rangle} \quad (25)$$

Due to the axial symmetry; it must hold that $\lim_{r \rightarrow 0} v = 0$ (26)

This requirement is fulfilled if $F \langle x \rangle = 0$, or

$$\frac{\nu^2}{a_o^2} \gamma_p \left\{ 1 + \frac{\gamma-1}{\gamma} \frac{J_2 \langle \alpha \sqrt{P_r} \rangle}{J_o \langle \alpha \sqrt{P_r} \rangle} \right\} - \frac{J_2 \langle \alpha \rangle}{J_o \langle \alpha \rangle} \frac{d^2_p}{dx^2} = 0 \quad (27)$$

From this differential equation p can be solved as:

$$p = A \exp \left[\frac{\nu x}{a_0} \sqrt{\frac{J_0 \langle \alpha \rangle}{J_2 \langle \alpha \rangle}} \left\{ \gamma + (\gamma-1) \frac{J_2 \langle \alpha \sqrt{P'_R} \rangle}{J_0 \langle \alpha \sqrt{P'_R} \rangle} \right\}^{1/2} \right] + B \exp \left[- \frac{\nu x}{a_0} \sqrt{\frac{J_0 \langle \alpha \rangle}{J_2 \langle \alpha \rangle}} \times \right. \\ \left. \left\{ \gamma + (\gamma-1) \frac{J_2 \langle \alpha \sqrt{P'_R} \rangle}{J_0 \langle \alpha \sqrt{P'_R} \rangle} \right\}^{1/2} \right] \quad (28)$$

introducing the notation

$$n = \frac{1}{1 + \frac{\gamma-1}{\gamma} \frac{J_2 \langle \alpha \sqrt{P'_R} \rangle}{J_0 \langle \alpha \sqrt{P'_R} \rangle}} \quad (29)$$

the general solution for the fluid motion in a tube yields:

$$p = A \exp \left[\frac{\nu x}{a_0} \sqrt{\frac{J_0 \langle \alpha \rangle}{J_2 \langle \alpha \rangle}} \sqrt{\frac{\gamma}{n}} \right] + B \exp \left[- \frac{\nu x}{a_0} \sqrt{\frac{J_0 \langle \alpha \rangle}{J_2 \langle \alpha \rangle}} \sqrt{\frac{\gamma}{n}} \right] \quad (30)$$

$$u = \frac{i}{a_0 \rho_s} \sqrt{\frac{J_0 \langle \alpha \rangle}{J_2 \langle \alpha \rangle}} \sqrt{\frac{\gamma}{n}} \left\{ \frac{J_0 \langle \frac{\alpha r}{R} \rangle}{J_0 \langle \alpha \rangle} - 1 \right\} \left\{ A \exp \left[\frac{\nu x}{a_0} \sqrt{\frac{J_0 \langle \alpha \rangle}{J_2 \langle \alpha \rangle}} \sqrt{\frac{\gamma}{n}} \right] - \right. \\ \left. - B \exp \left[- \frac{\nu x}{a_0} \sqrt{\frac{J_0 \langle \alpha \rangle}{J_2 \langle \alpha \rangle}} \sqrt{\frac{\gamma}{n}} \right] \right\} \quad (31)$$

$$v = - \frac{i \nu}{a_0^2 \rho_s} \left[\frac{1}{2} \left\{ 1 + \frac{J_0 \langle \alpha \rangle}{J_2 \langle \alpha \rangle} \frac{\gamma}{n} \right\} + \frac{(\gamma-1)R}{\alpha \sqrt{P'_R}} \frac{J_1 \langle \frac{\alpha r}{R} \sqrt{P'_R} \rangle}{J_0 \langle \alpha \sqrt{P'_R} \rangle} - \frac{R\gamma}{n\alpha} \frac{J_1 \langle \frac{\alpha r}{R} \rangle}{J_2 \langle \alpha \rangle} \right] p \quad (32)$$

$$\rho = \frac{\gamma}{a_0^2} \left[1 - \frac{\gamma-1}{\gamma} \left\{ 1 - \frac{J_0 \langle \frac{\alpha r}{R} \sqrt{P'_R} \rangle}{J_0 \langle \alpha \sqrt{P'_R} \rangle} \right\} \right] p \quad (33)$$

$$T = \frac{1}{\rho_s \mathcal{E} C_p} \left[1 - \frac{J_0 \langle \frac{\alpha r}{R} \sqrt{P'_R} \rangle}{J_0 \langle \alpha \sqrt{P'_R} \rangle} \right] p \quad (34)$$

The constants A en B can be determined after the boundary conditions at both ends of the tube have been prescribed.

Application

With the aid of the solutions (30) - (34) a system consisting of a series connection of N tubes and N volumes (fig.2) can be treated. To solve this problem some additional assumptions are made:

- the pressure and the density in the instrument volumes are only time dependent.
- the pressure expansion in the instrument volume is a polytropic process,

$$\text{described by } \left(\frac{\bar{p}_v}{\bar{\rho}_v}\right)^{k_j} = \text{constant} \quad (35)$$

For the flow through tube j the following expressions are valid:

$$p = A_j \exp(\phi_j X_j) + B_j \exp(-\phi_j X_j) \quad (36)$$

and

$$u = \frac{i}{\nu \rho_{sj}} \phi_j \left\{ \frac{J_o < \frac{\alpha_j R_j}{r} >}{J_o < \alpha_j >} - 1 \right\} \left\{ A_j \exp(\phi_j X_j) - B_j \exp(-\phi_j X_j) \right\} \quad (37)$$

$$\text{where } \phi_j = \frac{\nu}{a_{oj}} \sqrt{\frac{J_o < \alpha_j >}{J_2 < \alpha_j >}} \sqrt{\frac{r}{n_j}} \quad \text{and } j = 1, 2, 3, \dots, N \quad (38)$$

For tube j it holds:

$$\text{at the entrance: } X_j = 0 : p_{j-1} = A_j + B_j \quad (39)$$

$$\text{at the exit: } X_j = L_j : p_j = A_j \exp(\phi_j L_j) + B_j \exp(-\phi_j L_j) \quad (40)$$

$$u_{ji} = \frac{i}{\nu \rho_{sj}} \phi_j \left\{ \frac{J_o < \frac{\alpha_j R_j}{r} >}{J_o < \alpha_j >} - 1 \right\} \left\{ A_j \exp(\phi_j L_j) - B_j \exp(-\phi_j L_j) \right\} \quad (41)$$

and

$$\text{the mass leaving tube j: } m_{ji} = \int_0^{R_j} \rho_{sj} u_{ji} 2\pi r dr =$$

$$= \frac{\pi R_j^2 \phi_j}{i\nu} \frac{J_2 \langle \alpha_j \rangle}{J_0 \langle \alpha_j \rangle} \left\{ A_j \exp(\phi_j L_j) - B_j \exp(-\phi_j L_j) \right\} \quad (42)$$

For tube j+1 it holds:

$$\text{at the entrance : } X_{j+1} = 0 : \quad p_j = A_{j+1} + B_{j+1} \quad (43)$$

$$u_{j0} = \frac{i}{\nu \rho_{sj+1}} \phi_{j+1} \left\{ \frac{J_0 \langle \frac{\alpha_{j+1} R_{j+1}}{r} \rangle}{J_0 \langle \alpha_{j+1} \rangle} - 1 \right\} + \left\{ A_{j+1} - B_{j+1} \right\} \quad (44)$$

$$\begin{aligned} \text{the mass entering tube } j+1 : \dot{m}_{j0} &= \int_0^{R_{j+1}} \rho_{sj+1} u_{j0} 2\pi r dr \\ &= \frac{\pi R_{j+1}^2 \phi_{j+1}}{i\nu} \frac{J_2 \langle \alpha_{j+1} \rangle}{J_0 \langle \alpha_{j+1} \rangle} \left\{ A_{j+1} - B_{j+1} \right\} \quad (45) \end{aligned}$$

at the exit: $X_{j+1} = L_{j+1}$

$$\begin{aligned} p_{j+1} &= A_{j+1} \exp(\phi_{j+1} L_{j+1}) + \\ &B_{j+1} \exp(-\phi_{j+1} L_{j+1}) \quad (46) \end{aligned}$$

From eq (39) and (40) it can easily be found that:

$$A_j = \frac{p_j - p_{j-1} \exp(-\phi_j L_j)}{\exp(\phi_j L_j) - \exp(-\phi_j L_j)} \quad \text{and} \quad B_j = \frac{p_{j-1} \exp(\phi_j L_j) - p_j}{\exp(\phi_j L_j) - \exp(-\phi_j L_j)} \quad (47)$$

and from eq (43) and (46) it follows:

$$\begin{aligned} A_{j+1} &= \frac{p_{j+1} - p_j \exp(-\phi_{j+1} L_{j+1})}{\exp(\phi_{j+1} L_{j+1}) - \exp(-\phi_{j+1} L_{j+1})} \\ \text{and } B_{j+1} &= \frac{p_j \exp(\phi_{j+1} L_{j+1}) - p_{j+1}}{\exp(\phi_{j+1} L_{j+1}) - \exp(-\phi_{j+1} L_{j+1})} \quad (48) \end{aligned}$$

For the instrument volume it is assumed that

$$\frac{\bar{p}_v}{(\bar{\rho}_v)^{k_j}} = \frac{p_s + p_v e^{i\nu t}}{(\rho_s + \rho_v e^{i\nu t})^{k_j}} = \left(\frac{p_s}{\rho_{sj}}\right)^{k_j} \quad (49)$$

Considering small values of p_v ($=p_j$) and ρ_v eq (49) can be simplified to

$$p_j = a_{oj}^2 \frac{k_j}{\gamma} \rho_v \quad (50)$$

The instrument volume, corrected for diaphragm deflection is defined as:

$$V_{vj} (1 + \sigma_j \frac{p_j}{p_s} e^{i\nu t}) \quad (51)$$

The mass of air within this volume is then:

$$m_v = V_{vj} (1 + \sigma_j \frac{p_j}{p_s} e^{i\nu t}) (\rho_{sj} + \rho_v e^{i\nu t}) \approx V_{vj} (\rho_{sj} + \frac{\sigma_j \rho_{sj}}{p_s} p_j e^{i\nu t} + \frac{\gamma}{a_{oj}^2 k_j} p_j e^{i\nu t}) \quad (52)$$

The variation of mass within the instrument volume is:

$$\frac{dm_v}{dt} = \frac{i\nu\gamma}{a_{oj}^2} V_{vj} (\sigma_j + \frac{1}{k_j}) p_j e^{i\nu t} \quad (53)$$

The mass increase of the instrument volume must be equal to the difference in mass leaving tube j and the mass entering tube $j+1$, thus:

$$\frac{dm_v}{dt} = (m_{ji} - m_{jo}) e^{i\nu t} \quad (54)$$

Substituting the expressions (42), (45), (47), (48) and (53) into eq (54) the following recursion formula can be derived:

$$\frac{p_j}{p_{j-1}} = \left[\cos h \langle \phi_j L_j \rangle + \frac{V_{vj}}{V_{tj}} \left(\sigma_j + \frac{1}{k_j} \right) n_j \phi_j L_j \sin h \langle \phi_j L_j \rangle + \right. \\ \left. + \frac{V_{tj+1}}{V_{tj}} \frac{\phi_{j+1}}{\phi_j} \frac{L_j}{L_{j+1}} \frac{J_0 \langle \alpha_j \rangle}{J_0 \langle \alpha_{j+1} \rangle} \frac{J_2 \langle \alpha_{j+1} \rangle}{J_2 \langle \alpha_j \rangle} \frac{\sin h \langle \phi_j L_j \rangle}{\sin h \langle \phi_{j+1} L_{j+1} \rangle} \times \right. \\ \left. \left\{ \cos h \langle \phi_{j+1} L_{j+1} \rangle - \frac{p_{j+1}}{p_j} \right\}^{-1} \right] \quad (55)$$

with $V_{tj} = \pi R_j^2 L_j$, the volume of tube j.

From the recursion formule (55) the expressions for the complex ratio of the pressure fluctuation of each transducer j to the sinusoidal input pressure p_0 can be derived by successively putting $j = N, N-1, \dots, 2, 1$. It will be noted that for $j = N$ ^(the) last two terms of expression (55) disappear.

Table 1

Single pressure measuring systems (calculations)

R	L	V_v	σ	k	T_s	p_s	fig.	Remarks
0,50 mm	500 mm	300 mm ³	0	1,4	15° C	1 ata	9	Influence of R and L
0,75	"	"	"	"	"	"		
1,25	"	"	"	"	"	"		
0,50	1000	"	"	"	"	"	10	
0,75	"	"	"	"	"	"		
1,25	"	"	"	"	"	"		
0,50	3000	"	"	"	"	"	11	
0,75	"	"	"	"	"	"		
1,25	"	"	"	"	"	"		
0,75	1000	100	0	1,4	15	1	12	Influence of V_v
"	"	300	"	"	"	"		
"	"	1000	"	"	"	"		
0,75	1000	300	0	1,4	15	1	13	Influence of k
"	"	"	"	1,0	"	"		
0,75	1000	300	0	1,4	15	2	14	Influence of p_s
"	"	"	"	"	"	1		
"	"	"	"	"	"	0,5		
0,75	1000	300	0	1,4	0	1	15	Influence of T_s
"	"	"	"	"	30	1		

Table 2

Systems with discontinuity in tube radius (calculations)

L ₁ mm	L ₂ mm	R ₁ mm	R ₂ mm		
250	750	0,75	0,50	0,75	1,25
250	750	0,50	"	"	-
500	500	0,75	"	"	1,25
500	500	0,50	"	"	-
750	250	0,75	"	"	1,25

$V_{v1} = 0$
 $V_{v2} = 300 \text{ mm}^3$
 $G_2 = 0$
 $k_2 = 1,4$
 standard sea level
 conditions

Table 3

Single pressure measuring systems (calculations and experiments)

L mm	R _m mm
500	0,525
1000	0,49
1000	0,795
1000	1,09
3000	0,70
3910	0,965

$V_v = 285 \text{ mm}^3$
 $G = 0,02$

Table 4

Systems with discontinuity in tube radius (calculations and experiments)

L ₁	L ₂	R _{1m}	R _{2m}
500 mm	500 mm	0,525 mm	0,79 mm
500	500	0,79	0,525

$V_v = 285 \text{ mm}^3$
 $G = 0,02$

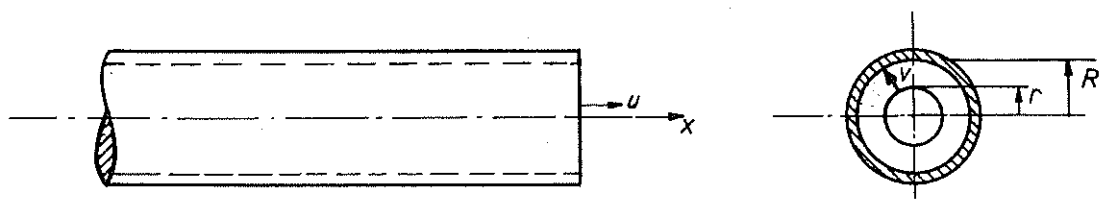

Fig.1 Co-ordinate system.

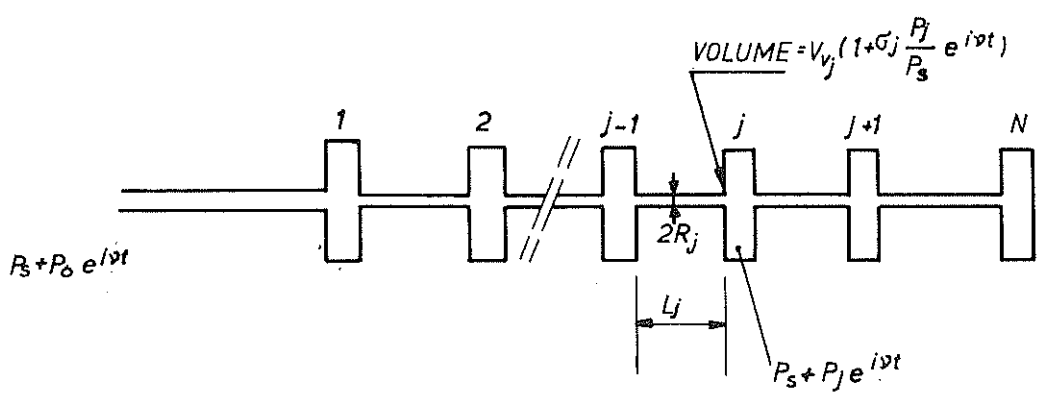

Fig.2 Series connection of tubes and transducers.

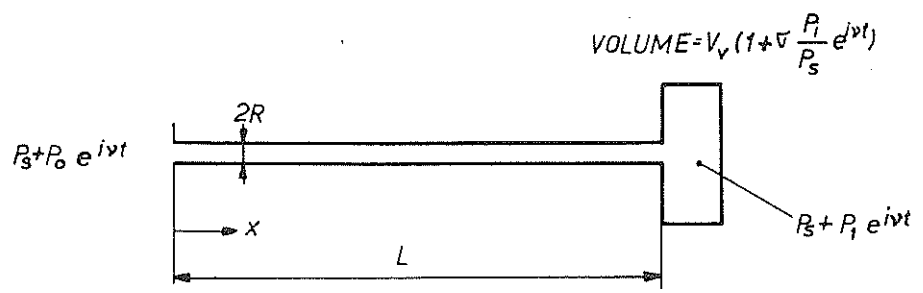

Fig.3 Single pressure measuring system.

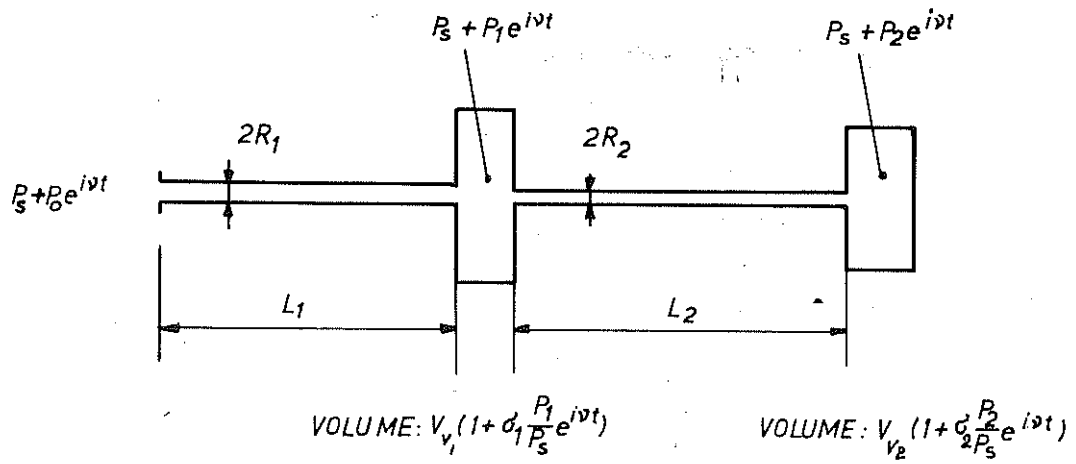

Fig.4 Double pressure measuring system.

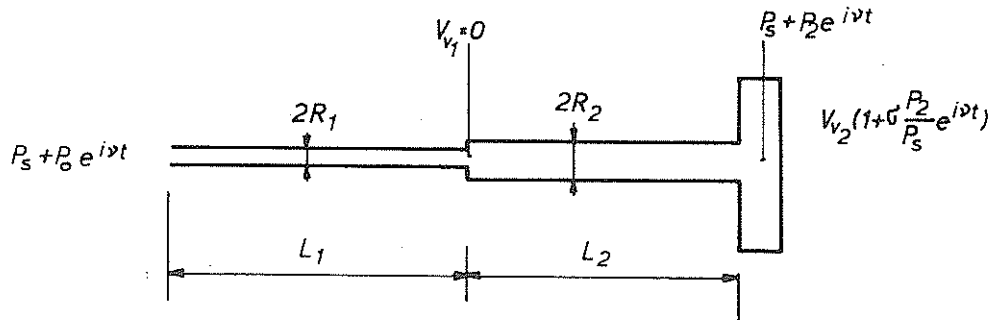

Fig.5 Tube with discontinuity in tube radius.

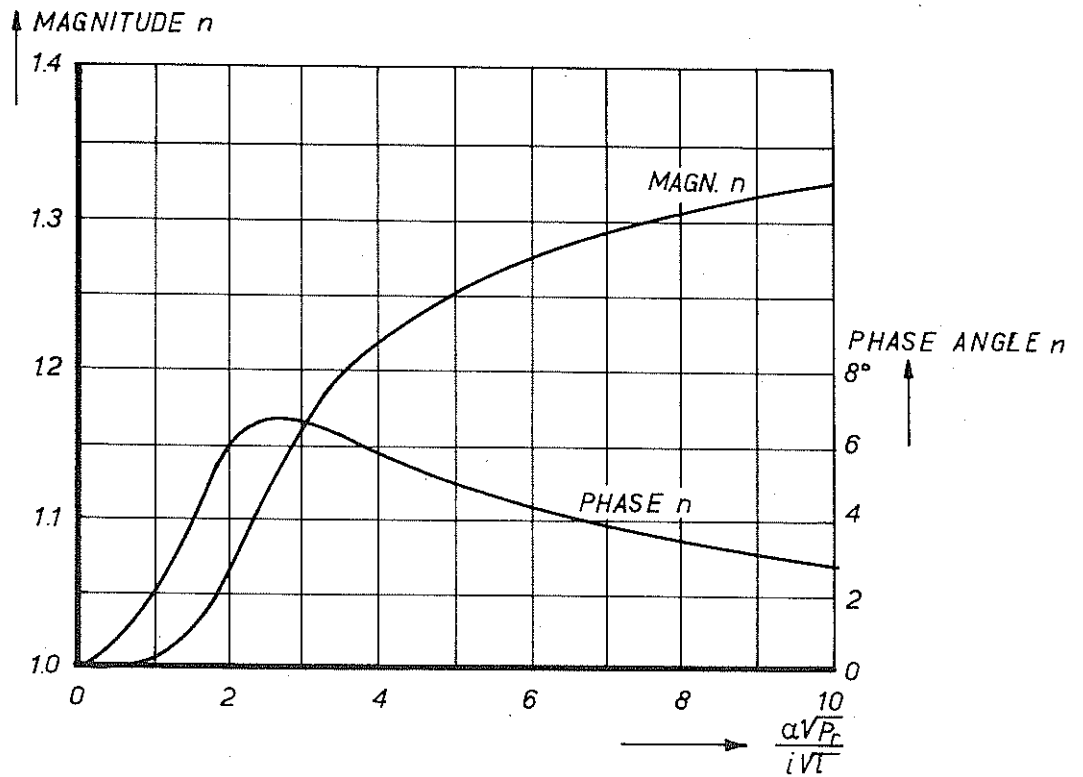

Fig.6 "Polytropic" factor n as a function of $\frac{\alpha\sqrt{P_r}}{i\sqrt{i}}$

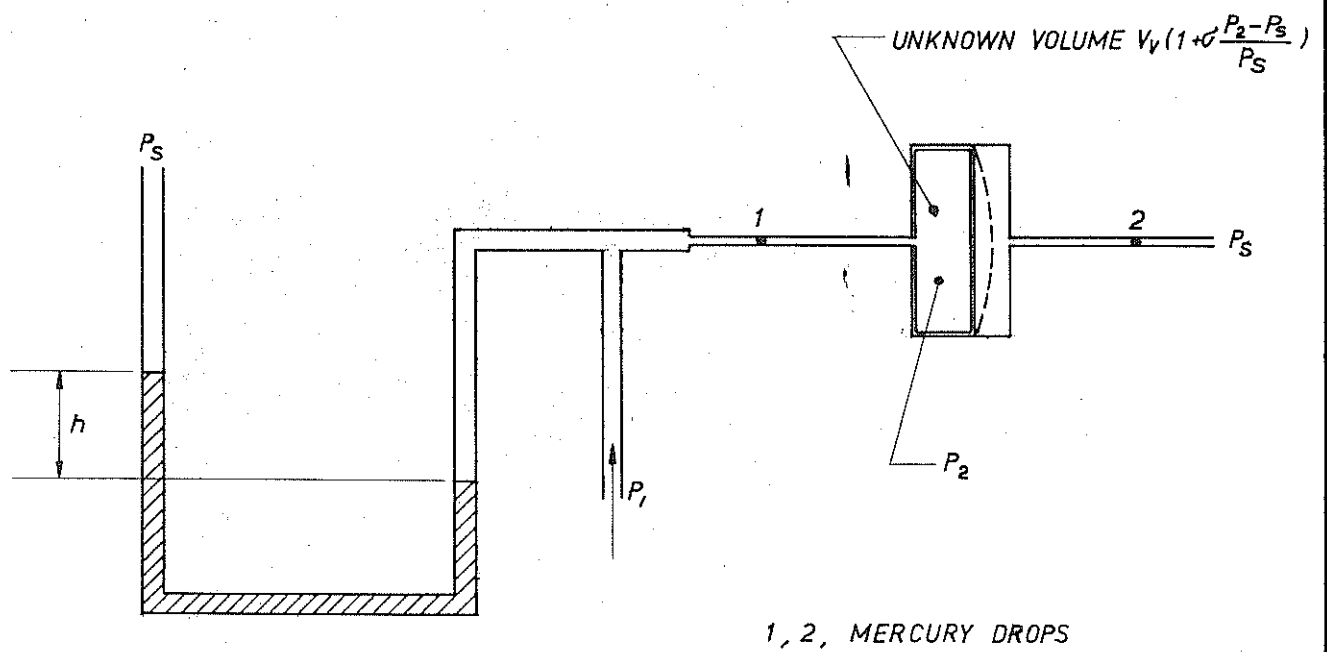

Fig.7 Test set up for the determination of V_v and γ .

Fig.8 Block diagram of equipment.

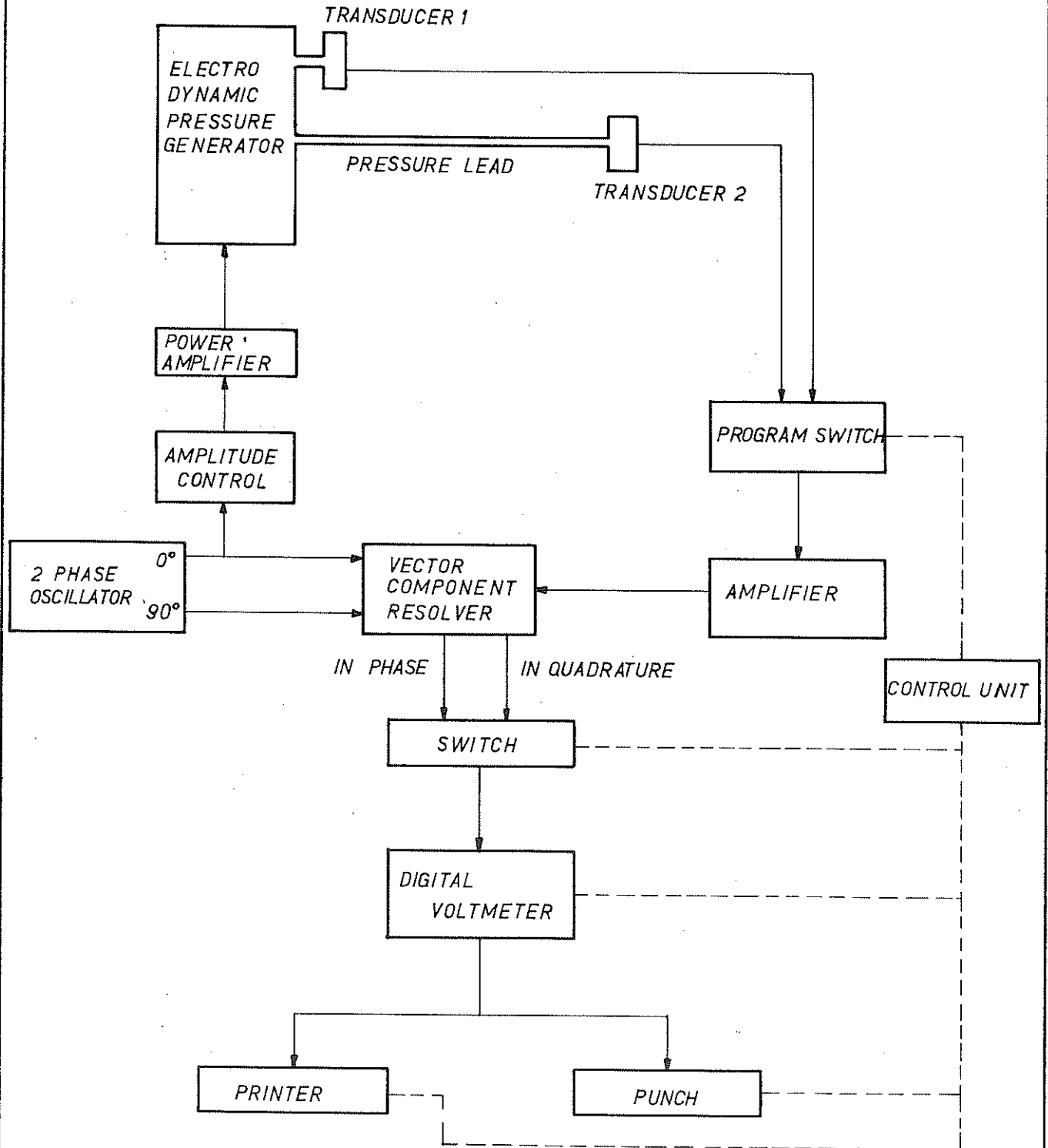

Fig.9 Influence of tube radius R on the dynamic response.

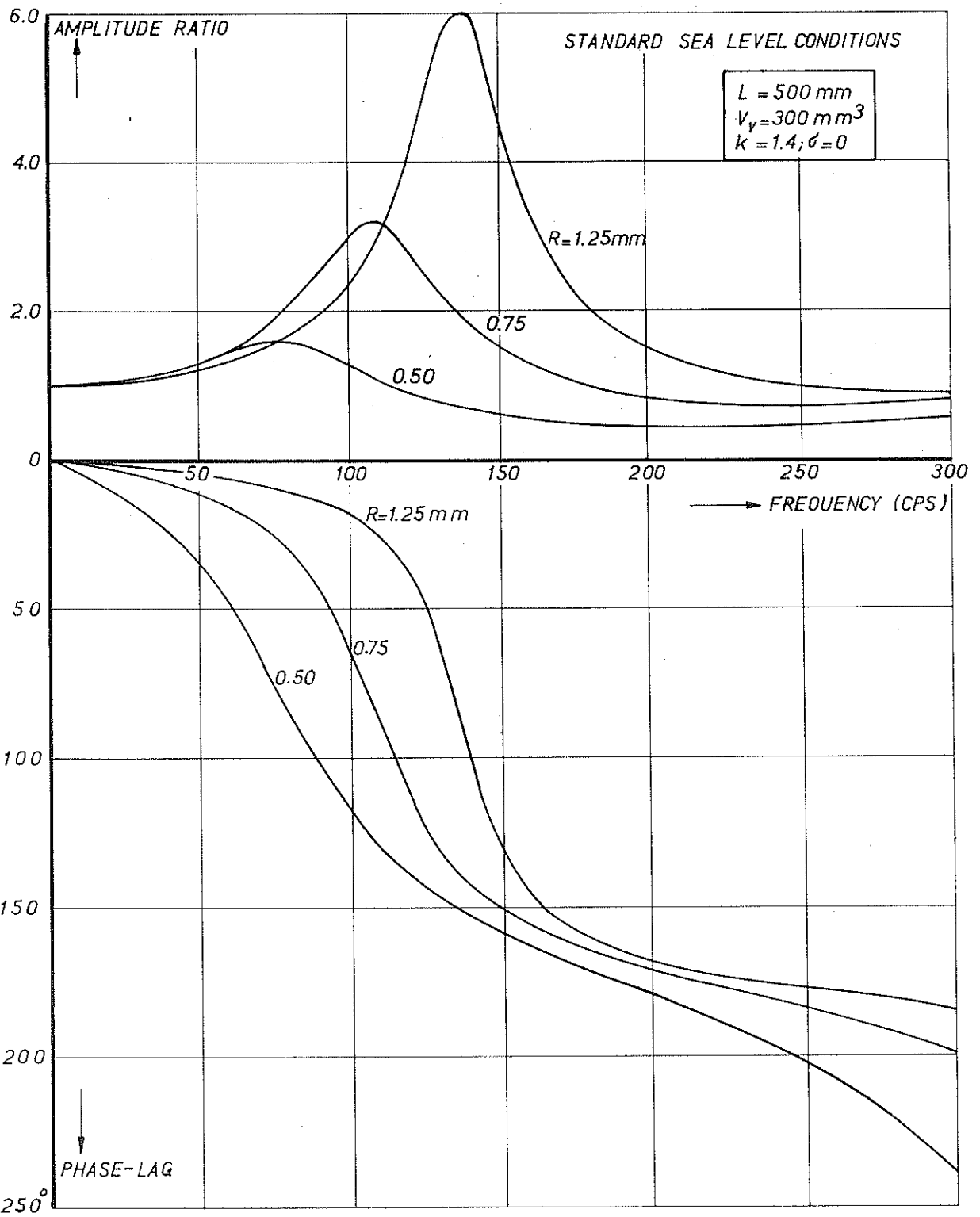

Fig.10 Influence of tube radius R on the dynamic response.

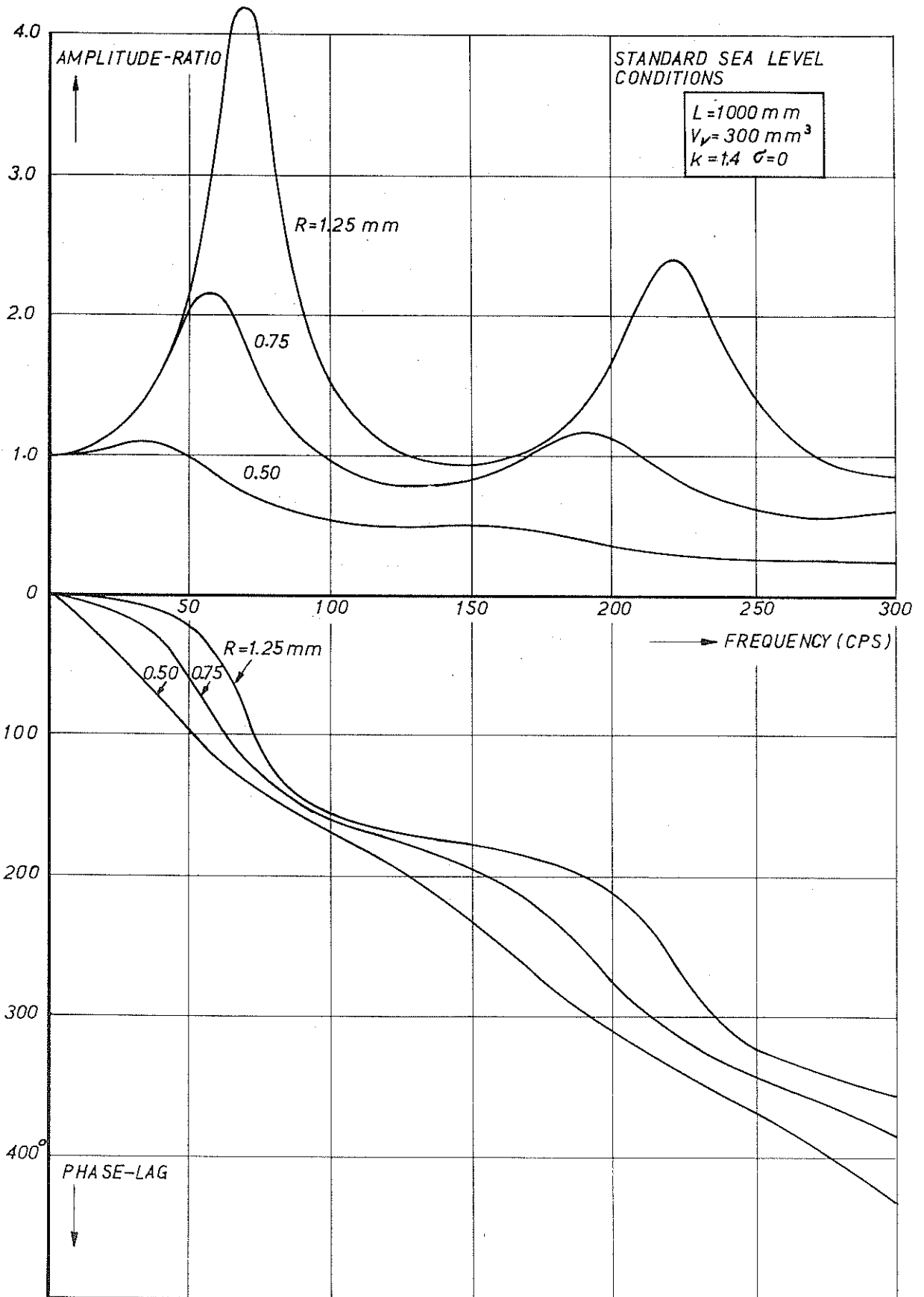

Fig.11 Influence of tube radius R on the dynamic response.

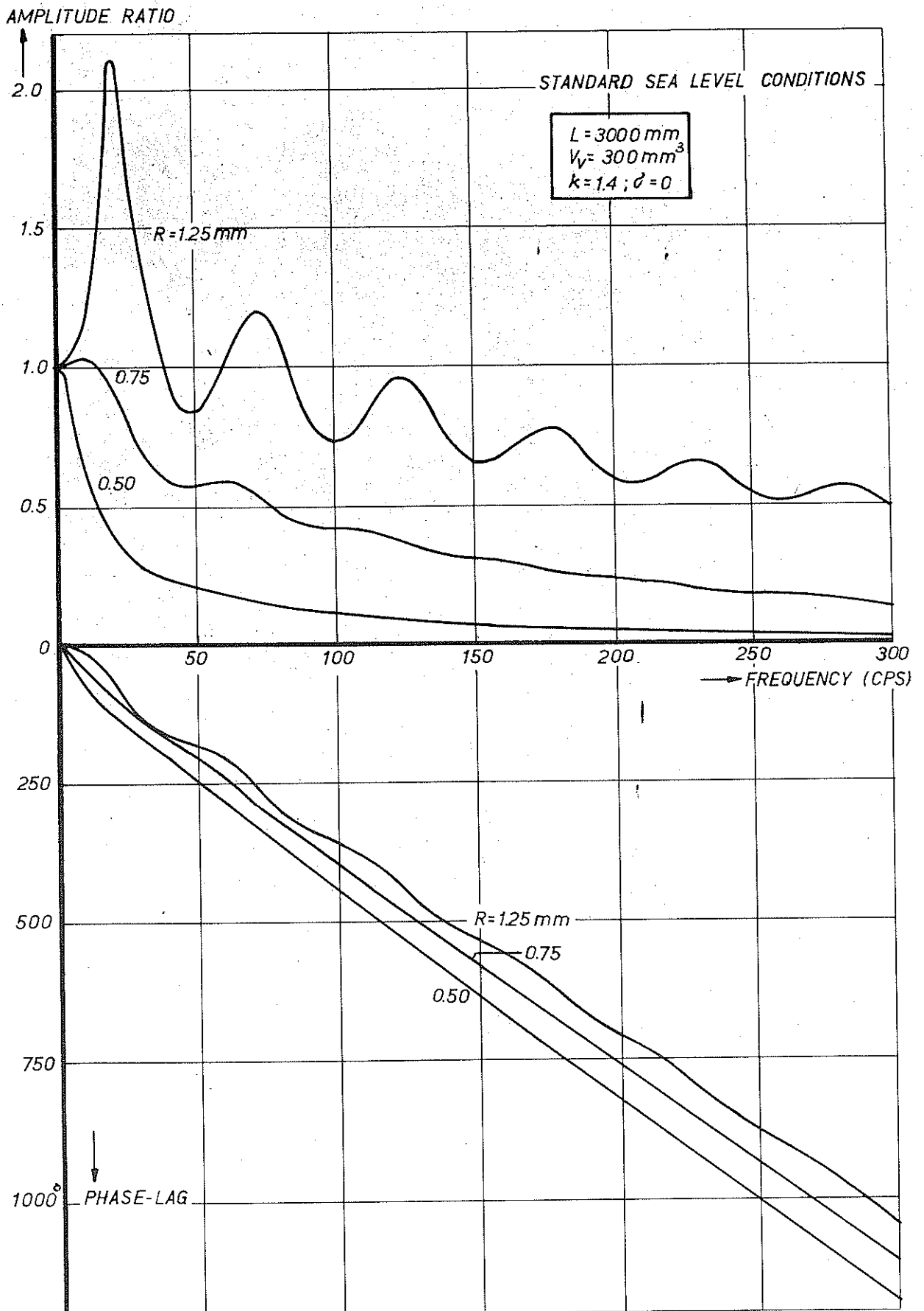

Fig.12 Influence of pressure transducer volume V_v on the dynamic response.

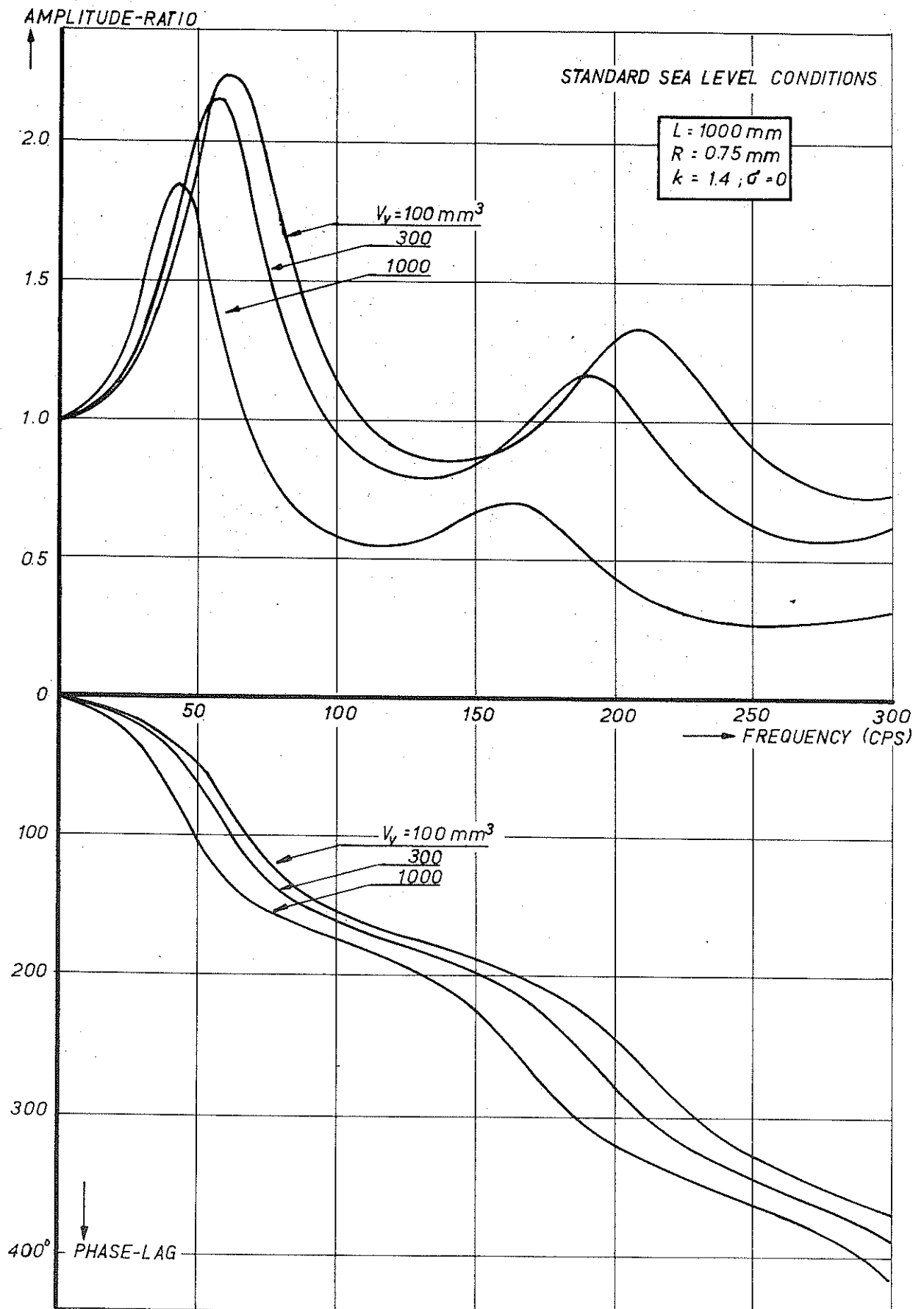

Fig.13 Influence of polytropic constant k on the dynamic response.

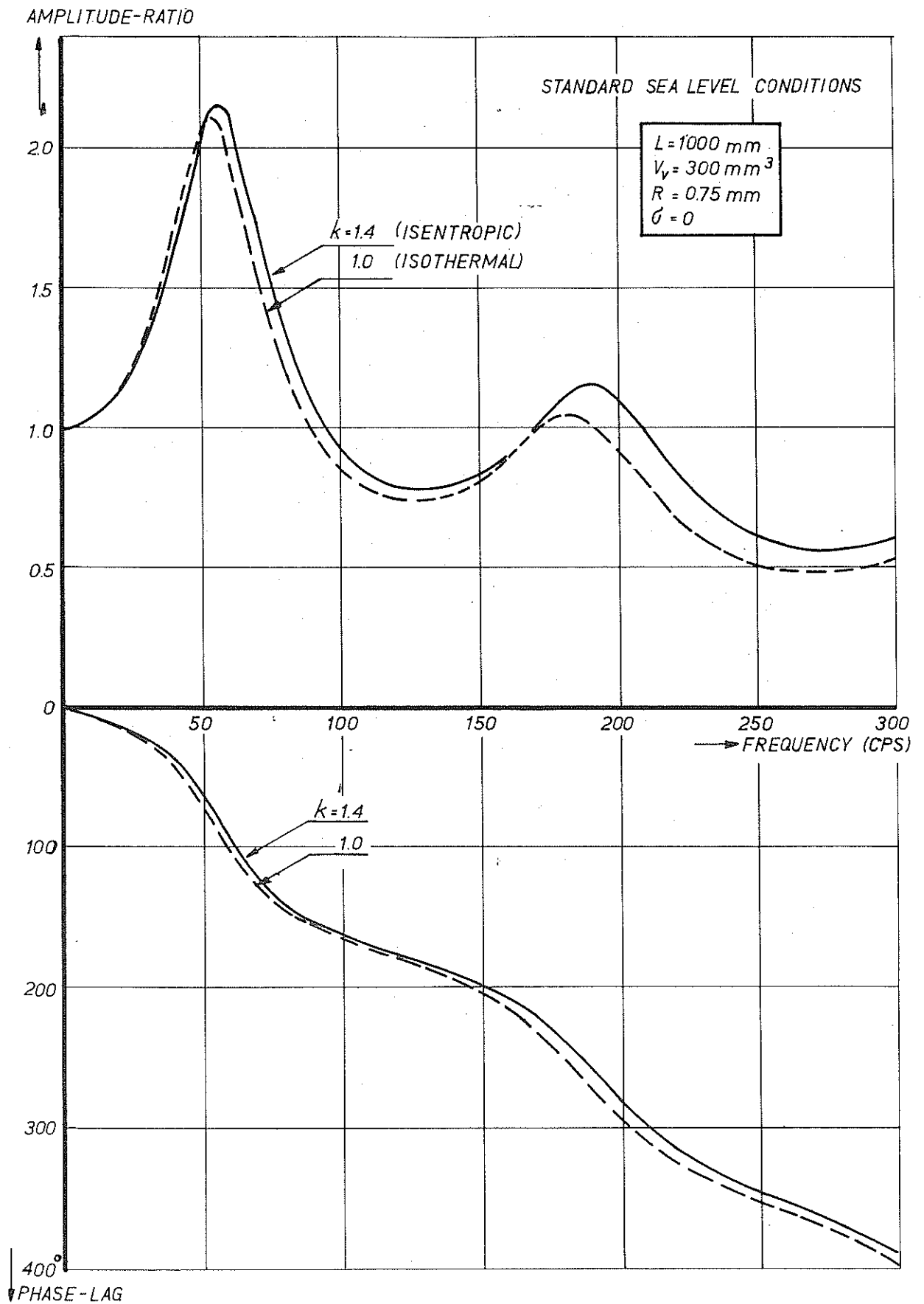

Fig.14 Influence of mean pressure on the dynamic response.

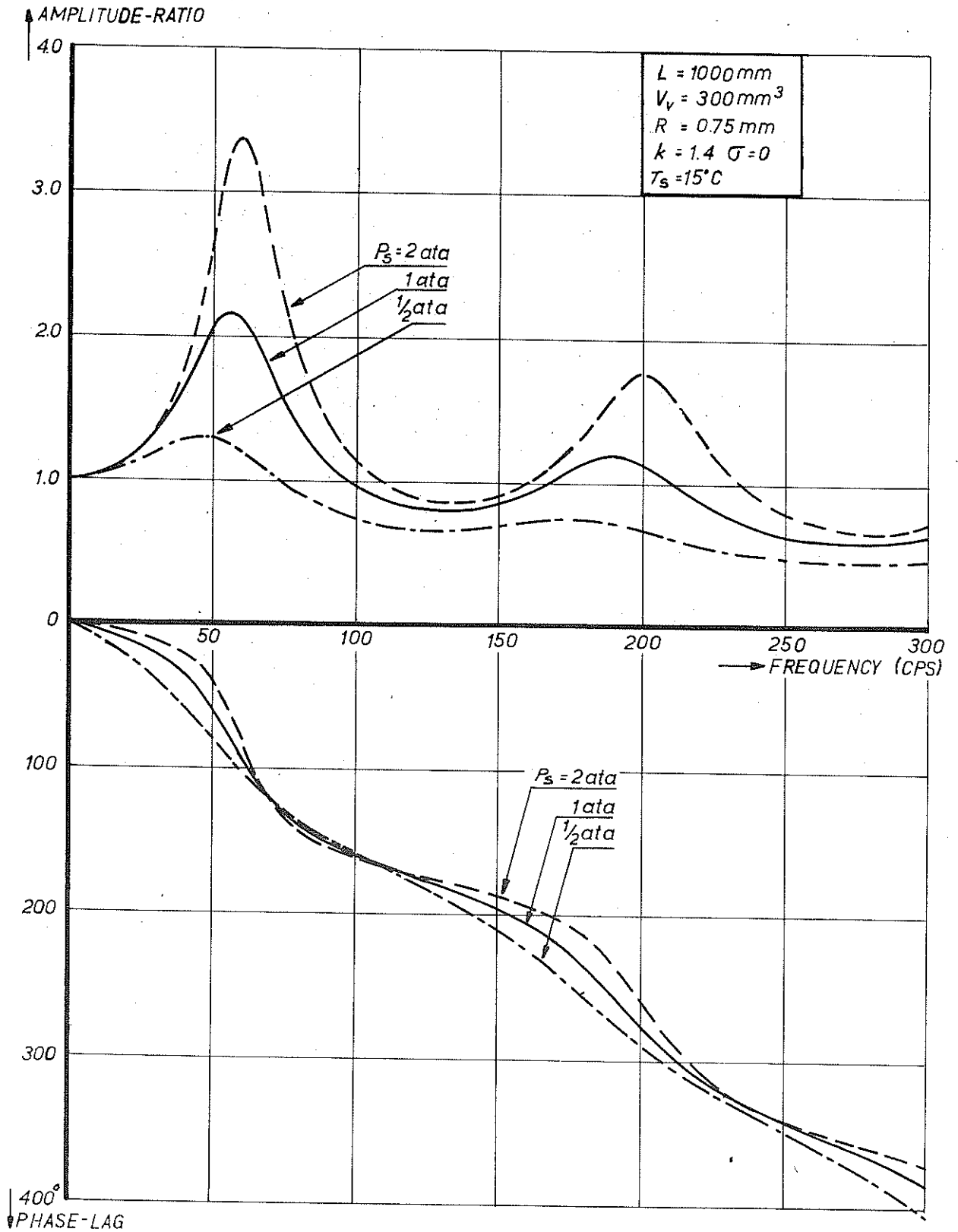

Fig.15 Influence of mean temperature on the dynamic response.

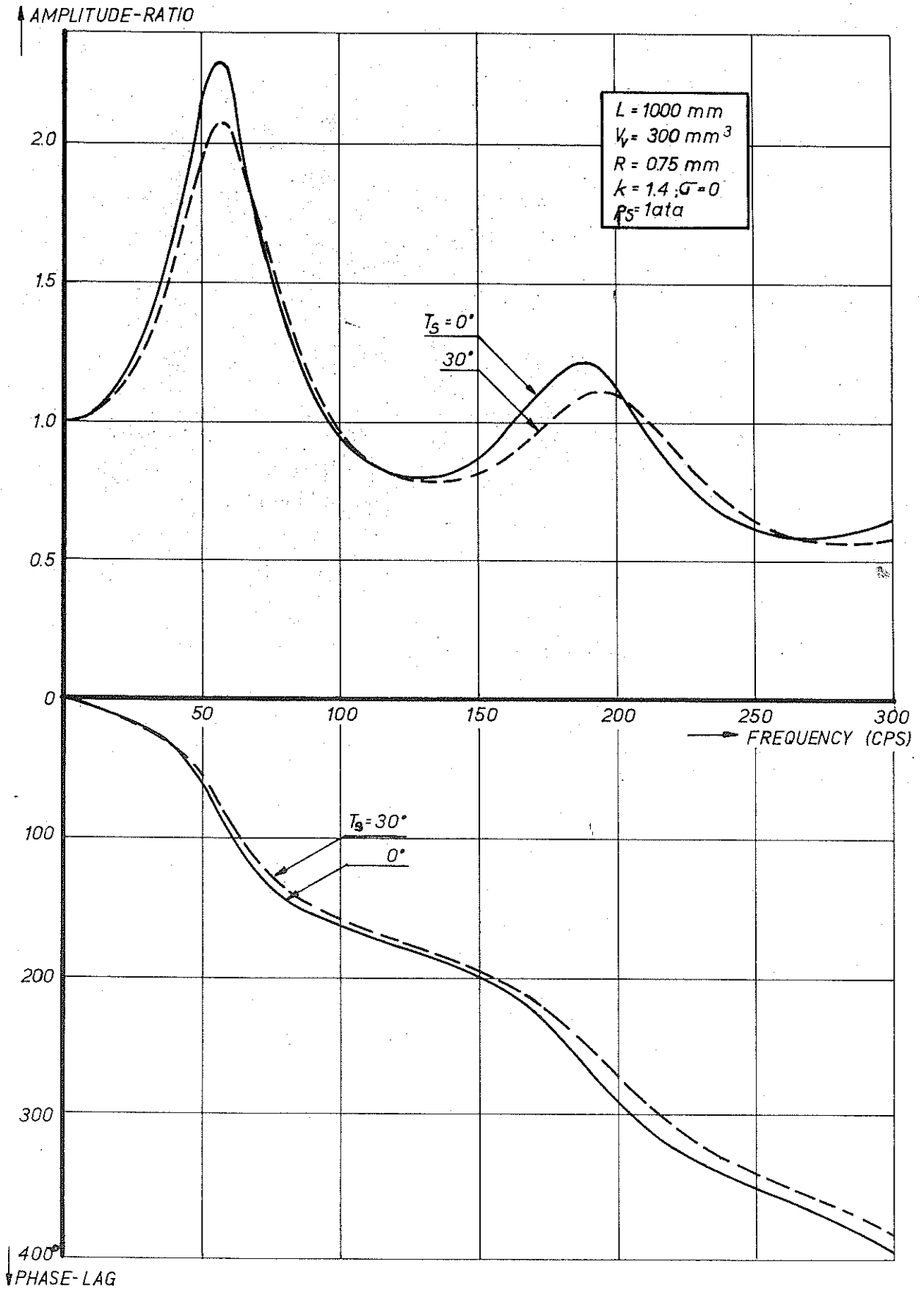

Fig.16 Influence of R_2 on the dynamic response of a double pressure measuring system.

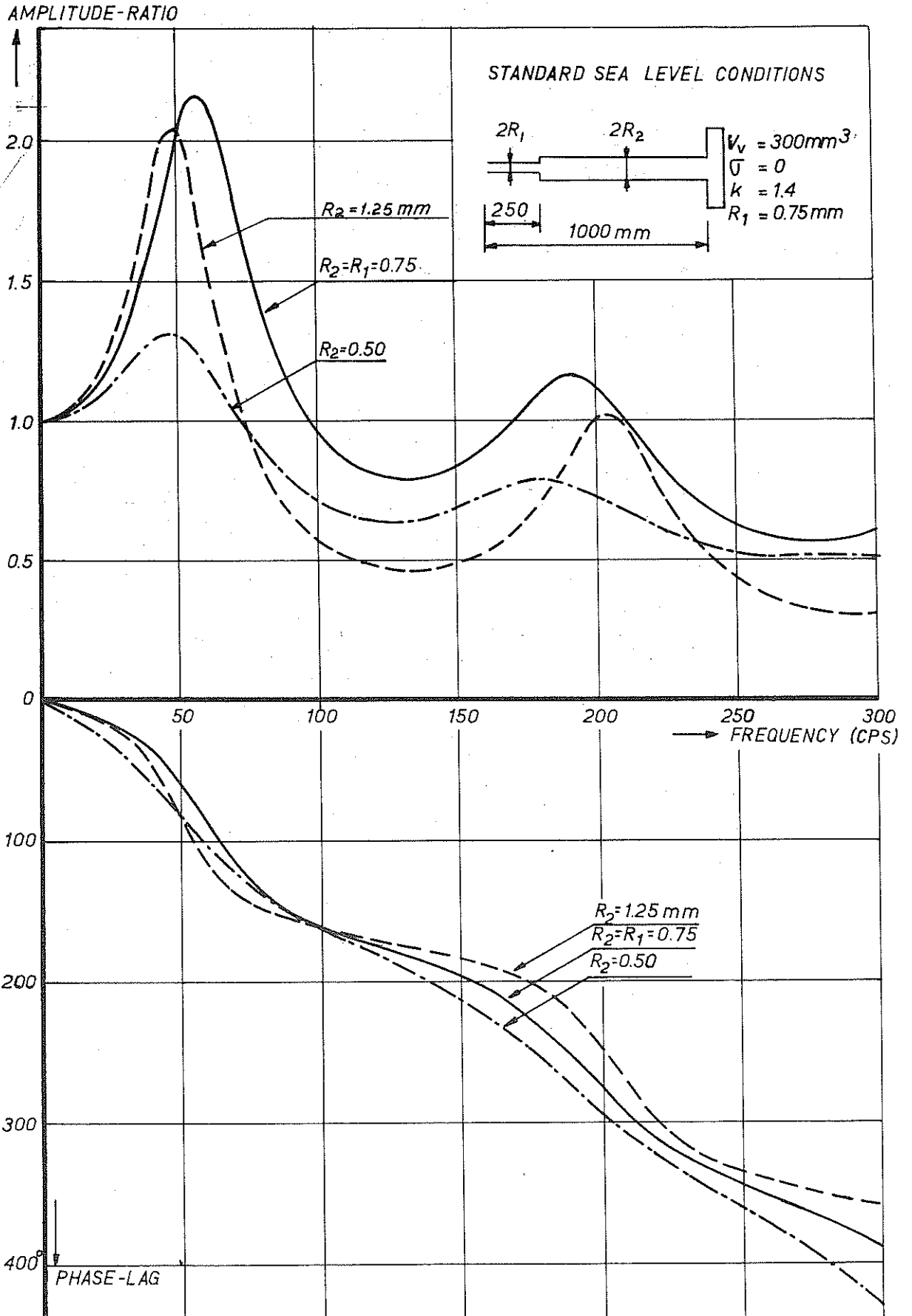

Fig.17 Influence of R_2 on the dynamic response of a double pressure measuring system.

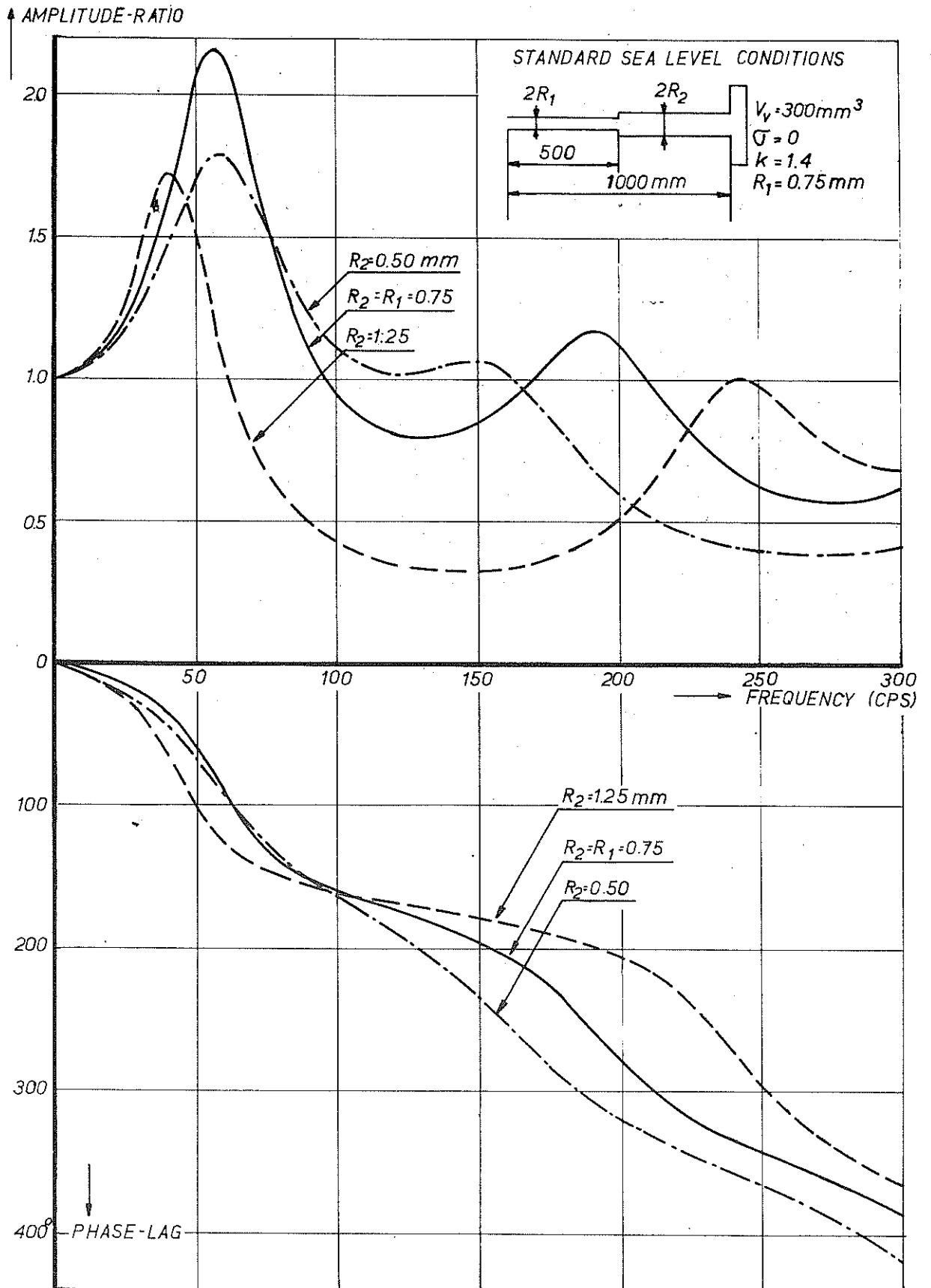

Fig.18 Influence of R_2 on the dynamic response of a double pressure measuring system.

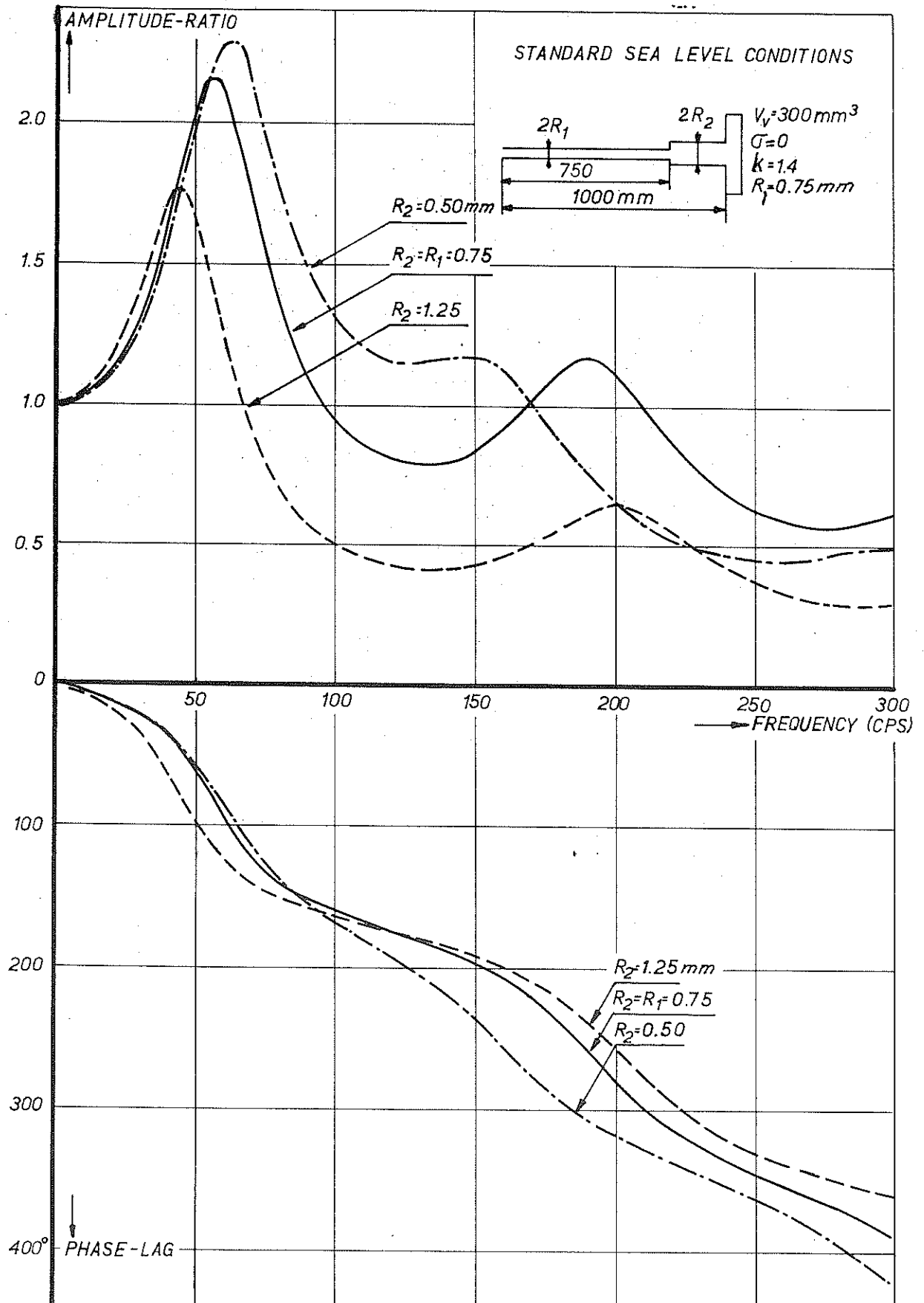

Fig.19 Influence of restrictions at the entrance and at the end of the tube

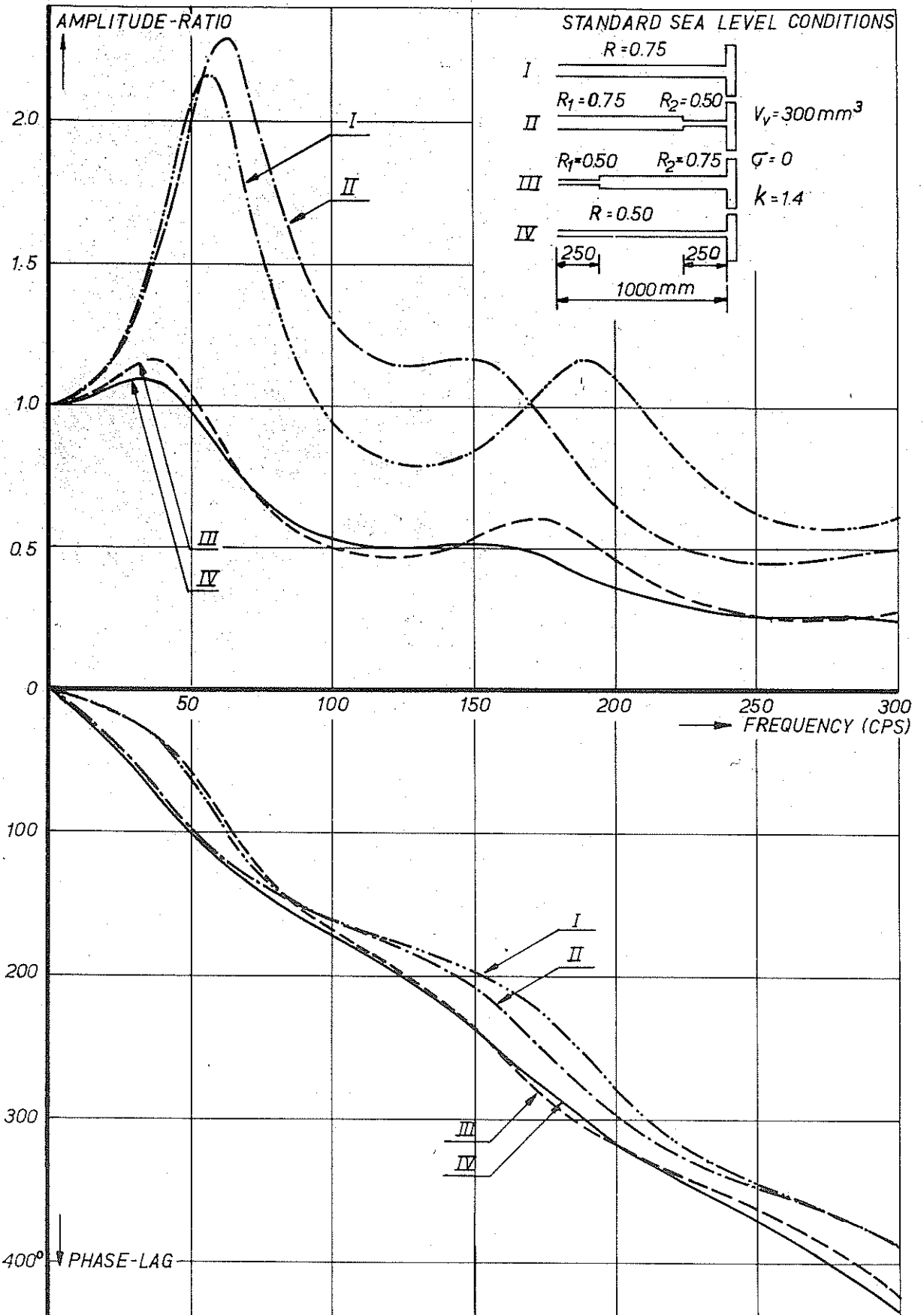

Fig.20 Influence of restrictions at the entrance and at the end of the tube.

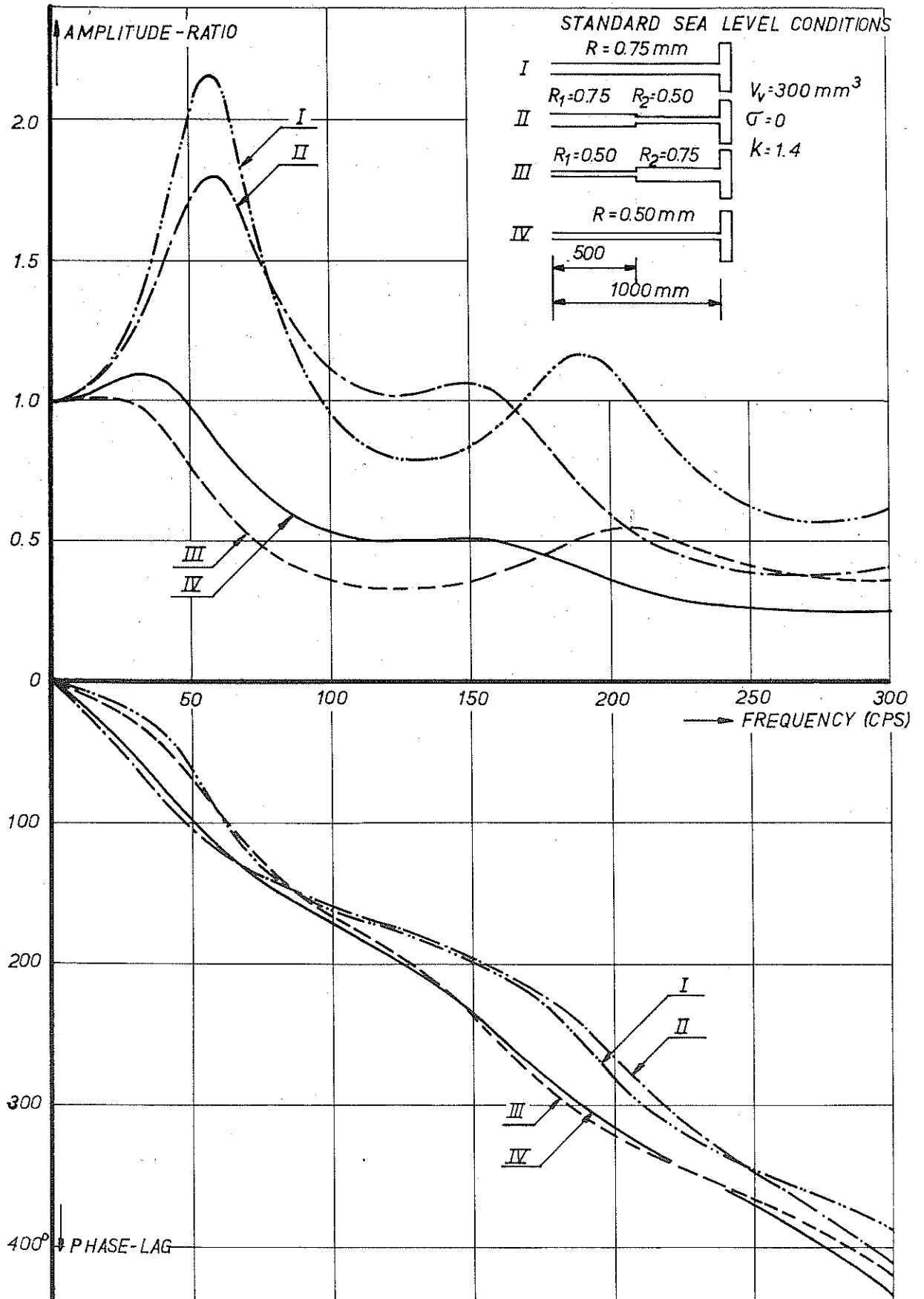

Fig.21 Experimental and theoretical results for a single pressure measuring system.

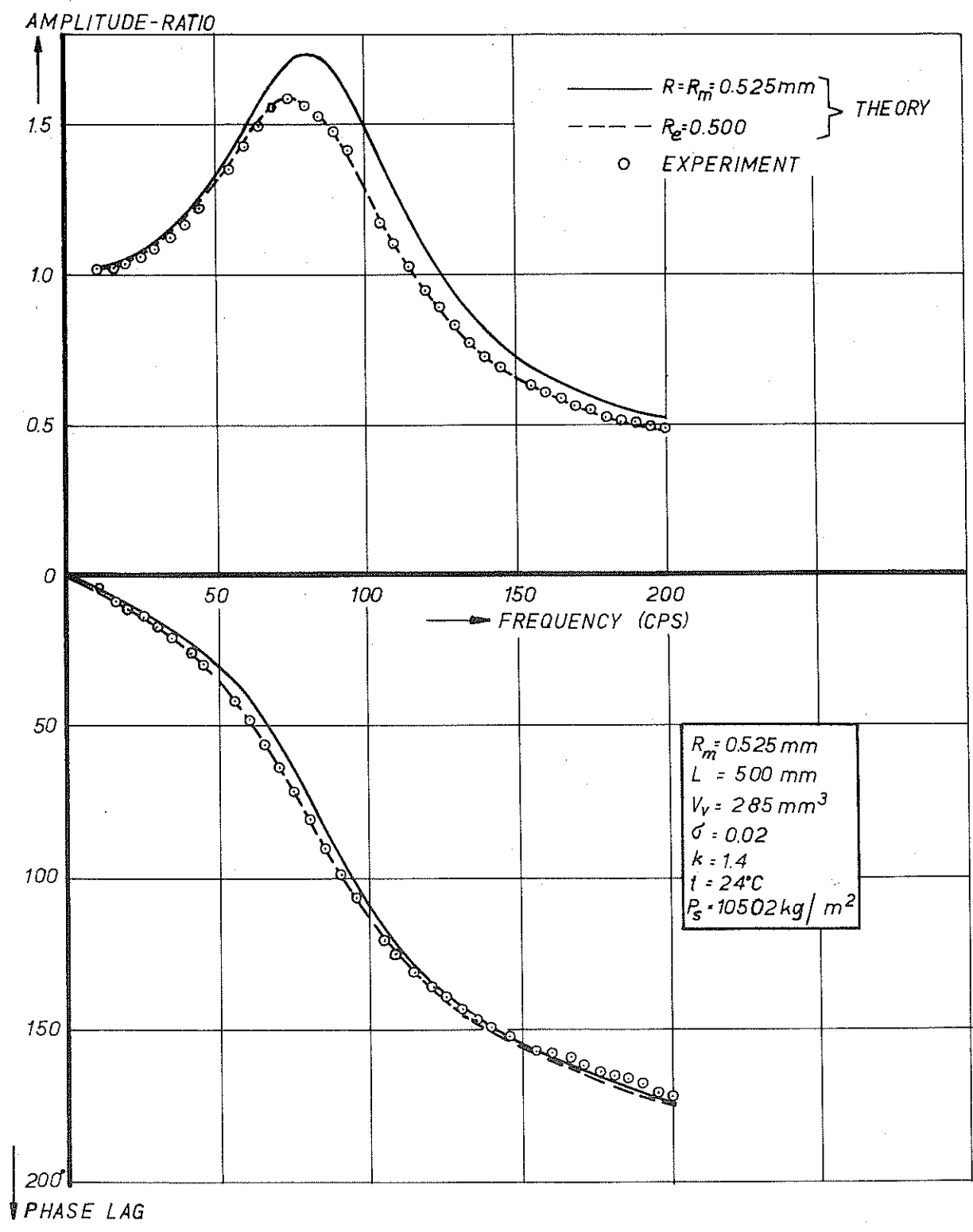

Fig.22 Experimental and theoretical results.

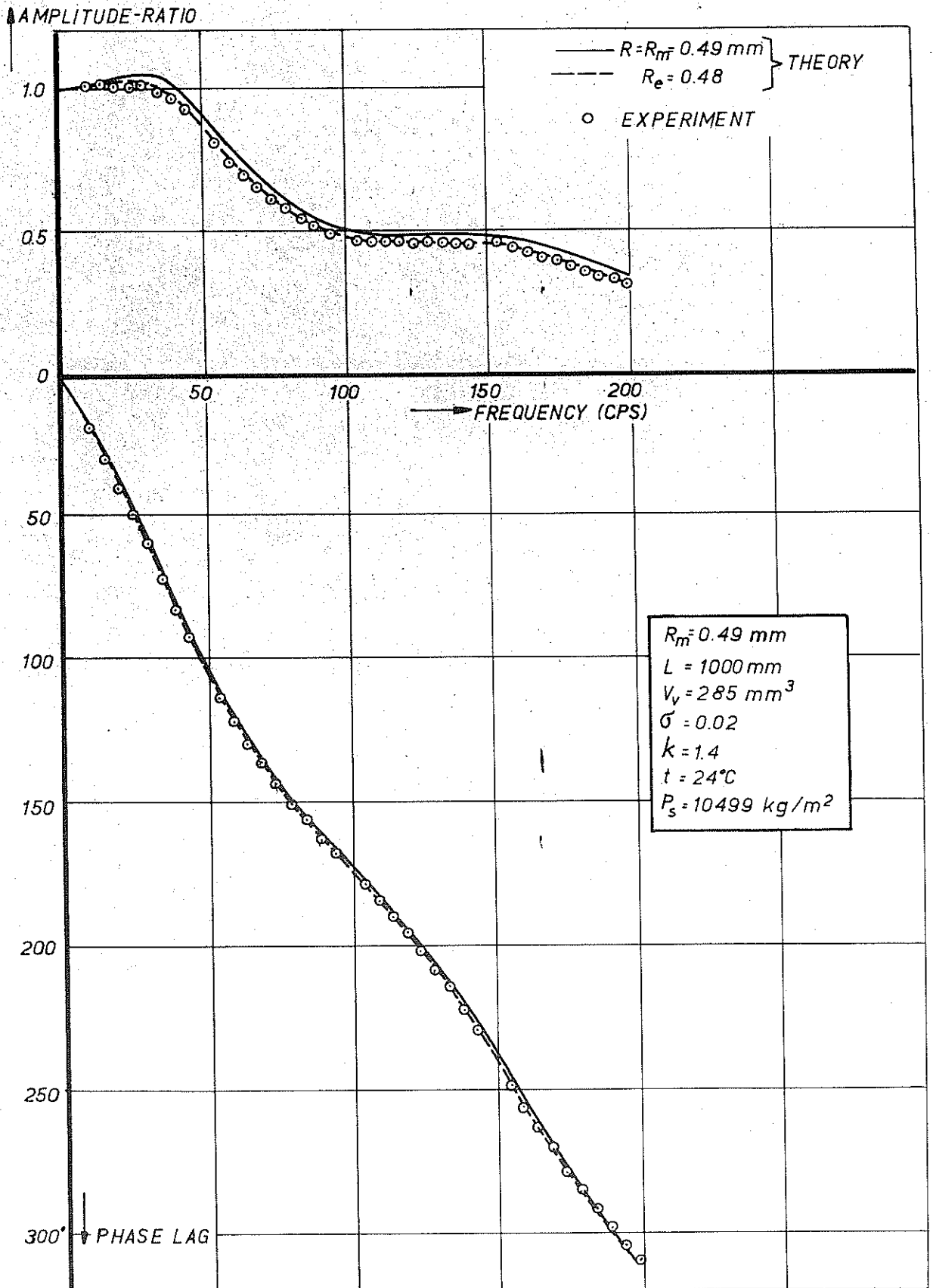

Fig.23 Experimental and theoretical results for a single pressure measuring system.

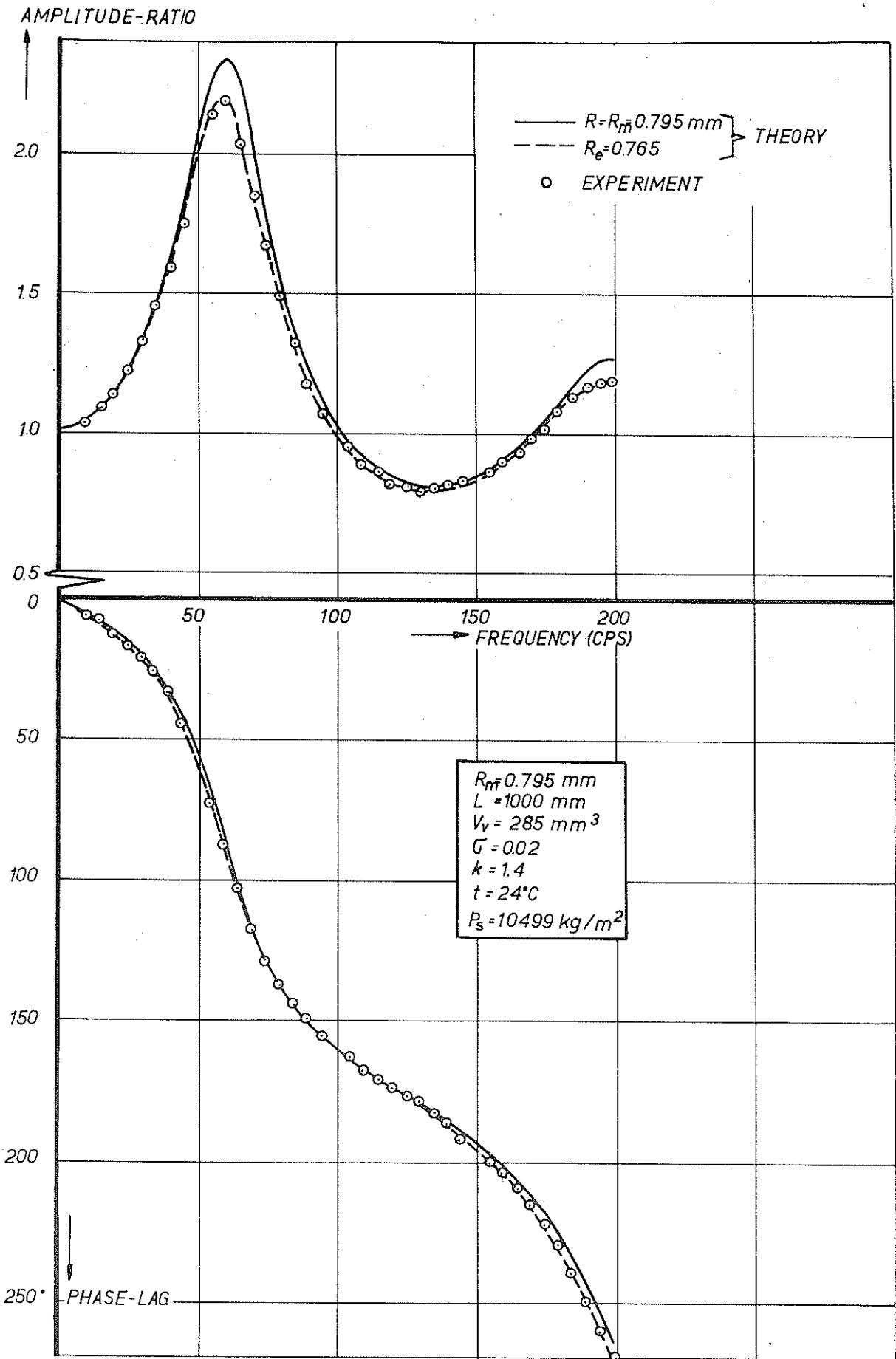

Fig. 24 Experimental and theoretical results for a single pressure measuring system.

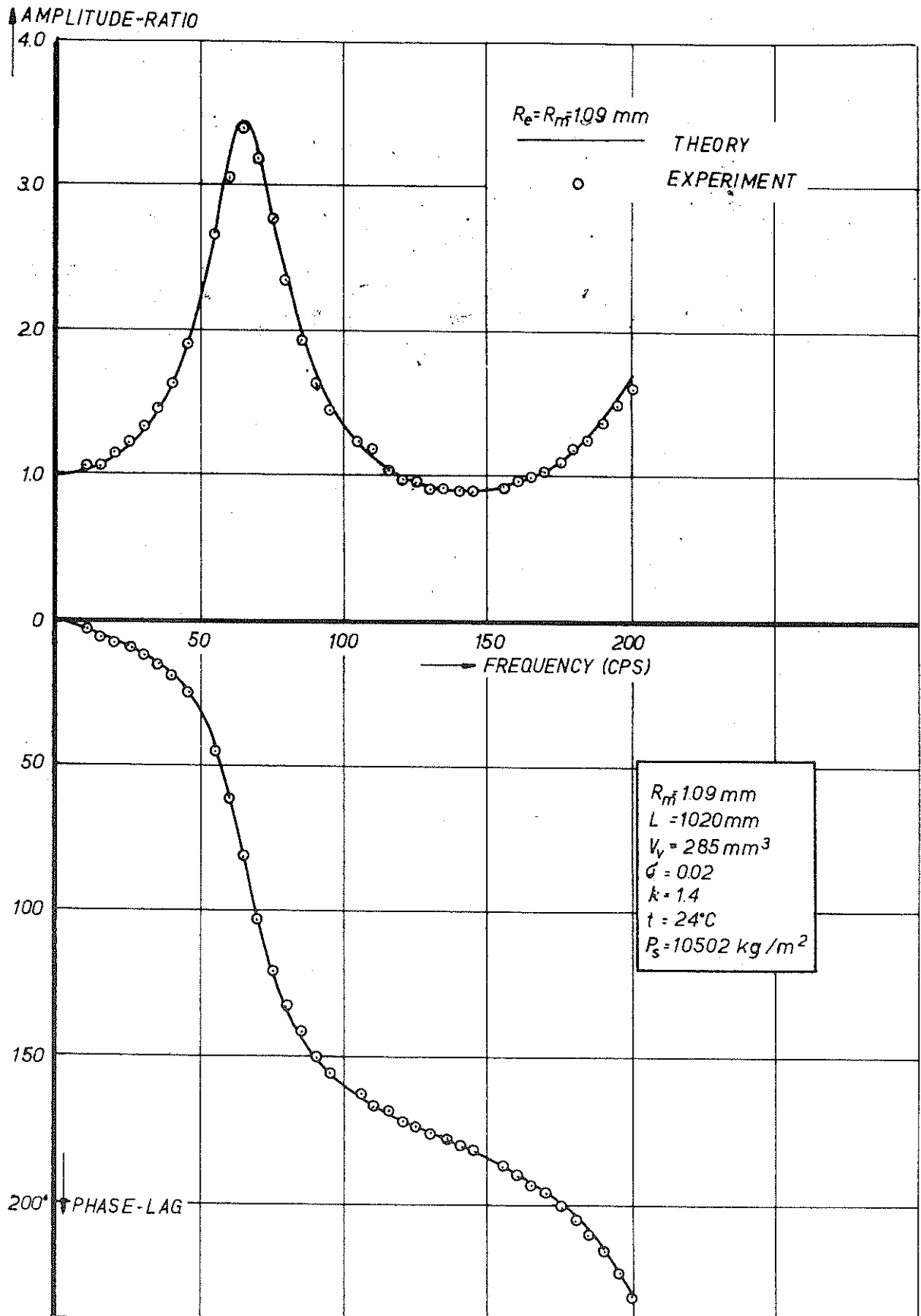

Fig.25 Experimental and theoretical results for a single pressure measuring system.

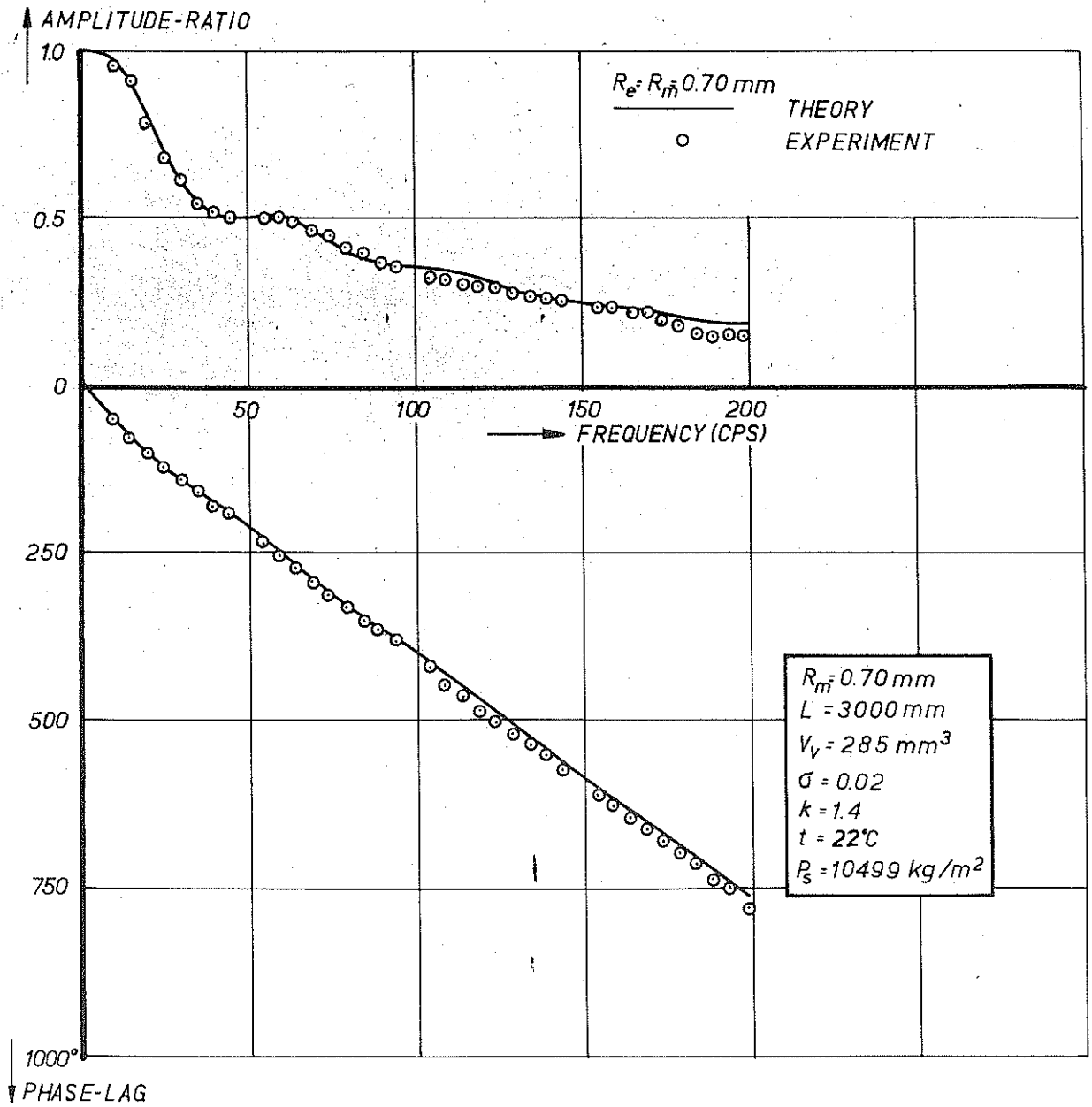

Fig.26 Experimental and theoretical results for a single pressure measuring system.

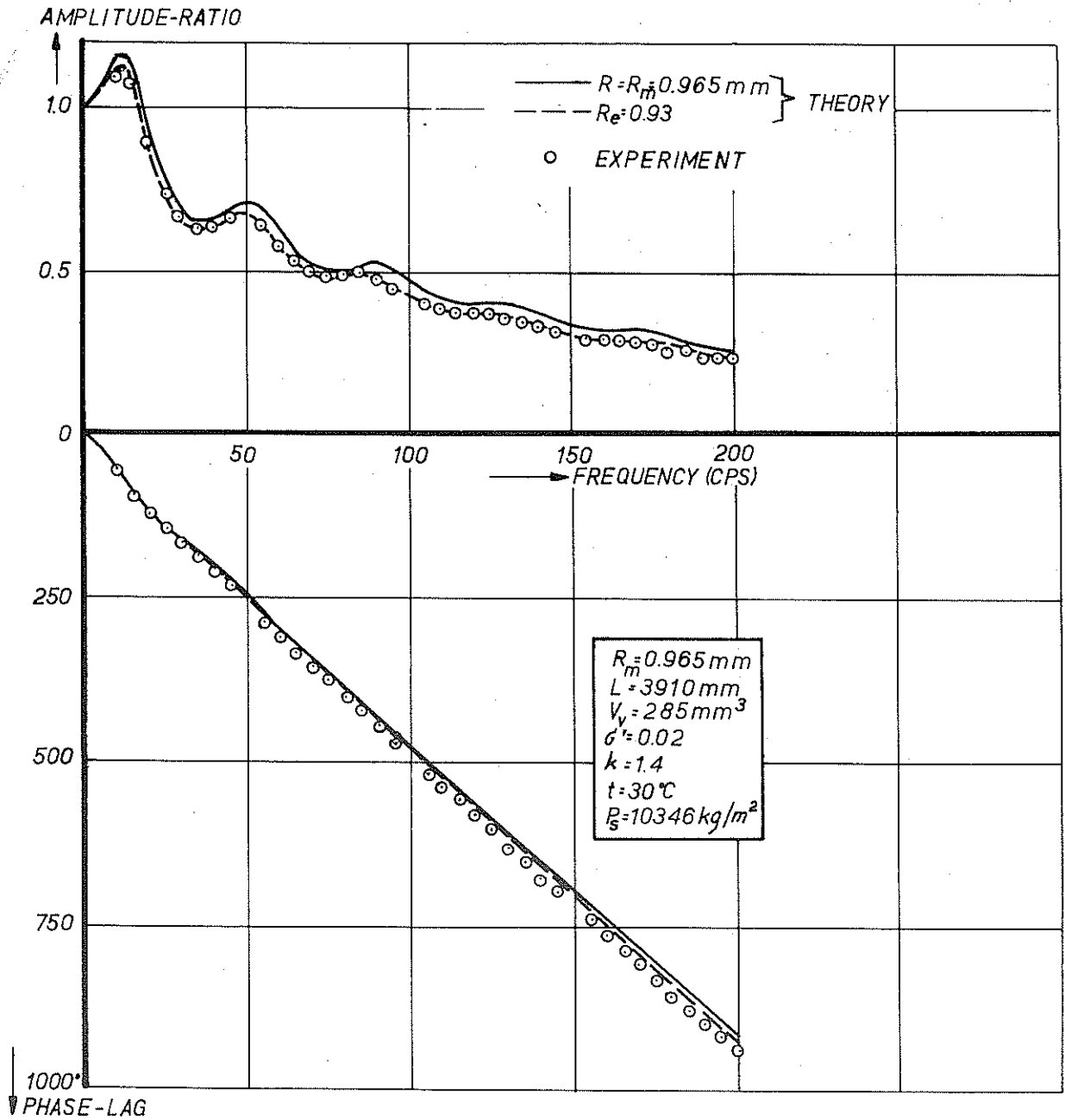

Fig.27 Experimental and theoretical results for a double pressure measuring system.

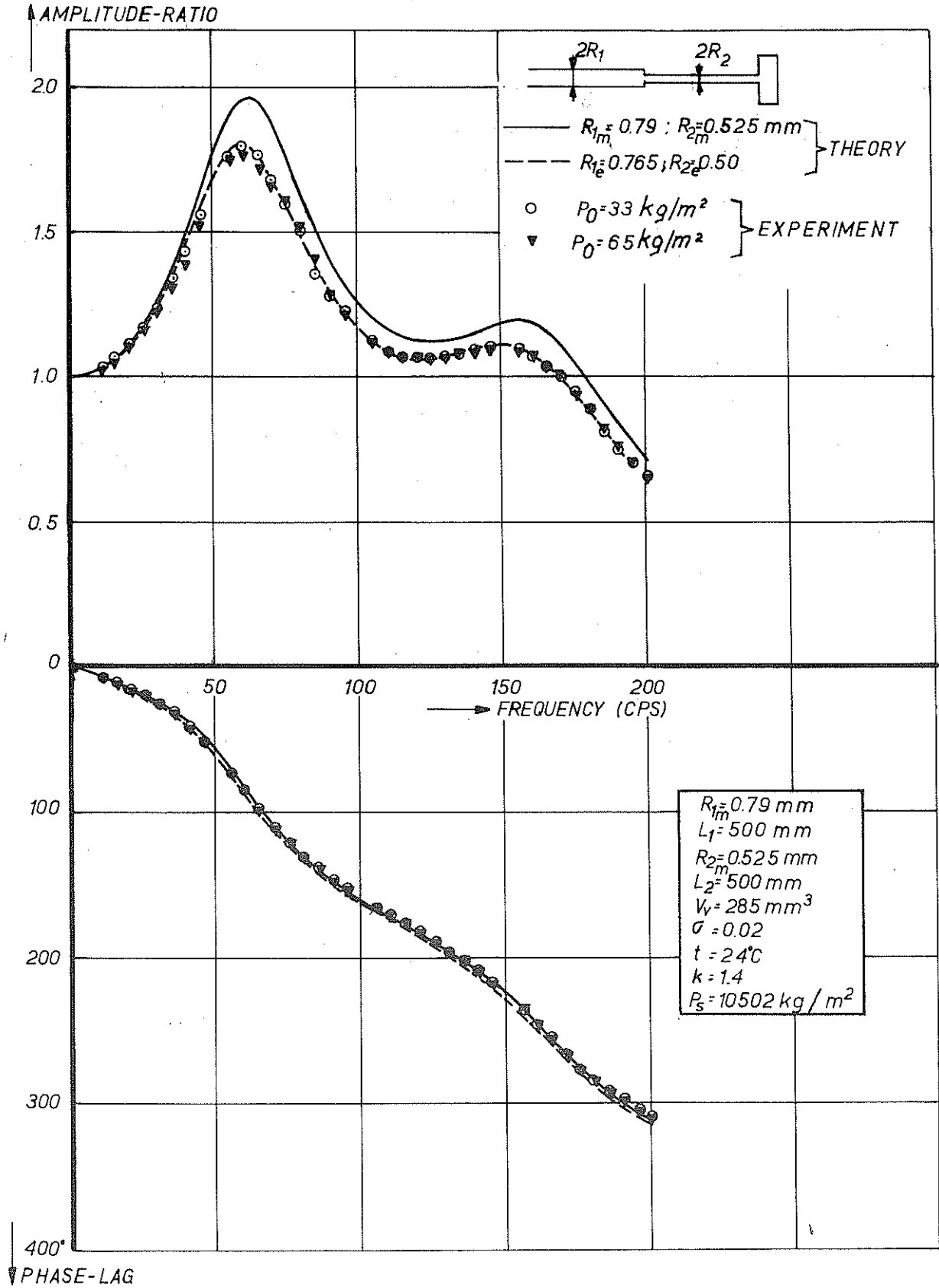

Fig.28 Experimental and theoretical results for a double pressure measuring system.

