

Appendix to report:

SBJ-33-C5-OON-22-RE-015-B
K12 - SHIP IMPACT, BRIDGE GIRDER

Appendix title:

APPENDIX B - MESH AND MATERIAL SENSITIVITY STUDY

Contract no: 18/91094
Project number: 5187772/12777
Document number: SBJ-33-C5-OON-22-RE-015-B App. B

Date: 15.08.2019
Revision: 0
Number of pages: 10

Prepared by: Marius Austnes
Controlled by: Thanh Ngan Nguyen
Approved by: Kolbjørn Høyland

CONCEPT DEVELOPMENT FLOATING BRIDGE E39 BJØRNAFJORDEN



Table of Content

1	MODEL	4
2	ALTERNATIVE MATERIAL MODELS	5
3	ELEMENT TYPES AND INTEGRATION POINTS	9
4	REFERENCES	10

A sensitivity study is performed to investigate how element size and mesh scaling affect material fracture and energy dissipation.

3

Three sets of analysis have been conducted:

- BWH model without mesh scaling
- BWH model with mesh scaling
- FLD and FLSD material model

1 MODEL

To evaluate the material model and mesh size for the large-scale simulations it is chosen to perform the sensitivity study on a limited model with the same characteristics as the large-scale simulations. Geometry:

- Plate size: 6000 mm x 6000 mm. Thickness 10 mm
- Stiffeners: c/c 3000 mm, L-profiles 300x100x10 mm
- Indenter: Analytical rigid: Diameter 1000 mm with 100 mm edge fillet

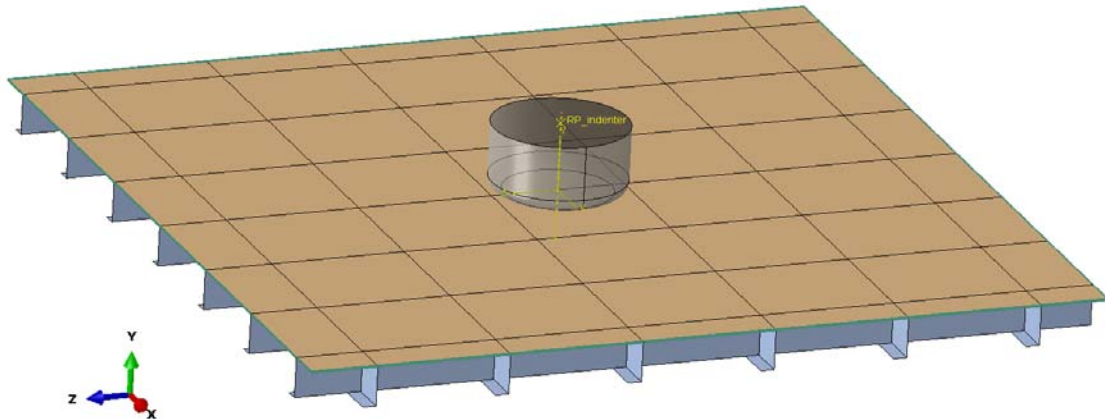

> Figure B-1 Geometry of model for mesh sensitivity study

Analysis set-up:

- Boundary conditions: Pinned
- Constant velocity of indenter: 6.2 m/s
- Step time: 0.3 sec

The material is set to S275 according to DNV RP-208 [1] with low fractile material coefficients.

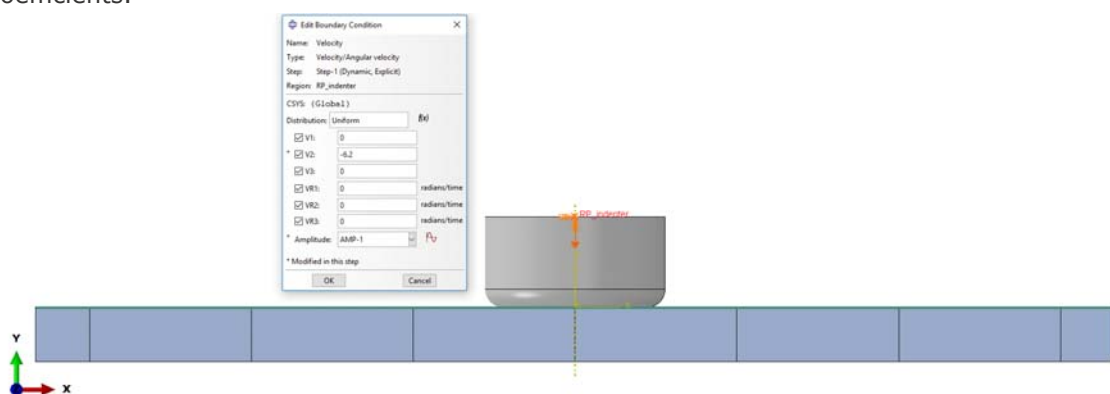

> Figure B-2 Analysis set-up

2 ALTERNATIVE MATERIAL MODELS

For reference it is chosen to use a standard strain-based FLD (Forming Limit Diagram) material described in the Abaqus documentation [2] and a stress-based FLSD (Forming Limit Stress Diagram). Description of the model is according to the Abaqus documentation module. For the elastic and plastic range of the material model values and fasting curves are according to DNV-RP 208 [1], see Figure B-3.

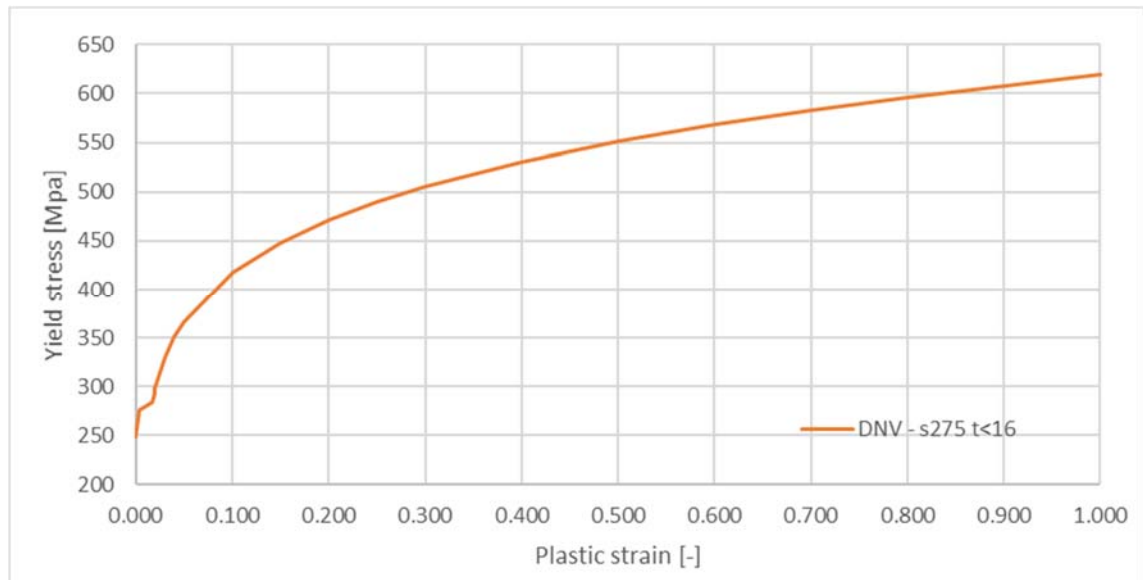

> Figure B-3 Plasticity according to DNV-RP 208. Low fractile values for S275 [1]

Figure B-4 illustrates the characteristic stress-strain behavior of a material undergoing damage according to the FLD and FLSD material models. In the context of an elastic-plastic material with isotropic hardening, the damage manifests itself in two forms: softening of the yield stress and degradation of the elasticity. The solid curve in the figure represents the damaged stress-strain response, while the dashed curve is the response in the absence of damage.

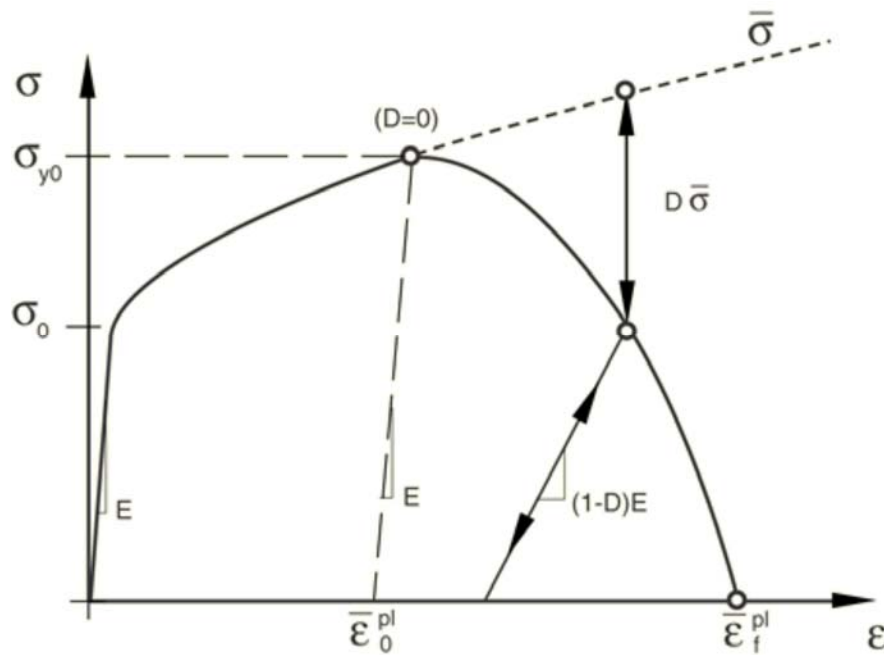

> Figure B-4 Principle for damage evolution materials in Abaqus [2]

The FLD is used to determine the amount of deformation the material can withstand before the onset of necking instability. The states at which the deformation becomes unstable is described by the relation between major (e_1) and minor strains (e_2). The line connecting these states is referred to as the Forming Limit Curve (FLC). Major and minor strains refer to the maximum and minimum values of the in-plane principle limit strains, respectively. It is chosen to use the Swift instability criterion [3]. The Swift instability criterion is given as:

$$\begin{pmatrix} e_1 \\ e_2 \end{pmatrix} = \begin{pmatrix} \frac{2n(2-\alpha)(1-\alpha+\alpha^2)}{4-3\alpha-3\alpha^2+4\alpha^3} \\ \frac{2n(1-2\alpha)(1-\alpha+\alpha^2)}{4-3\alpha-3\alpha^2+4\alpha^3} \end{pmatrix}$$

where $\alpha = \sigma_1 / \sigma_2$ and n is the power law exponent. The Swift instability describe a diffuse neck initiation, see plot in Figure 3-7 [4].

For comparison the Storen and Rice bifurcation curve is used [3]:

$$e_1 = \frac{3\beta^2 + n(2 + \beta)^2}{2(2 + \beta)(1 + \beta + \beta^2)}$$

where n is the power law exponent and β is the strain increment ratio.

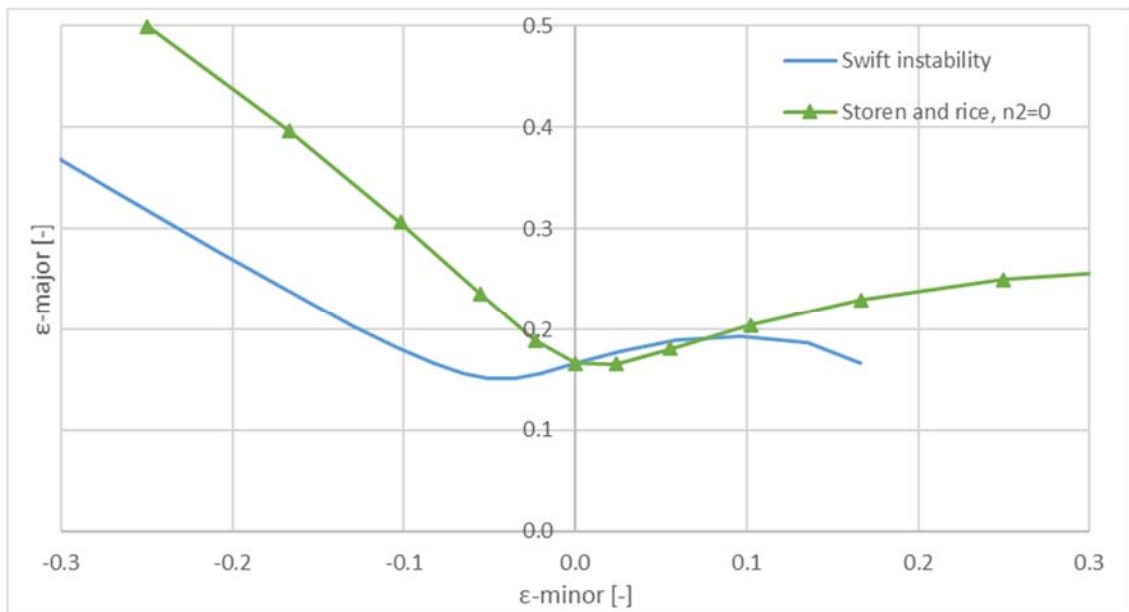

> Figure B-5 Forming Limiting Curve (FLC) according to the Swift instability. Exemplified for S275.

A stress based FLSD material model based on the FLC-material with the Swift instability is established. The conversion from FLD to FLSD is done with the same relation as described for the BWH-material in section 3-3 [4].

It is chosen to define the damage evolution based on linear effective plastic displacement. The damage evolution parameter is set to the same value for the FLD and FLSD materials. The damage parameter is set to

$$\frac{\dot{u}^{pl}}{L} = L \dot{\bar{\epsilon}}^{pl}$$

where L is the characteristic element length and is equal to the element length for first-order elements. $\dot{\bar{\epsilon}}^{pl}$ is the equivalent plastic strain. Equivalent plastic strain at failure is set according to the gross yielding check in section 5.1.3.2 in DNV-RP 208 [1].

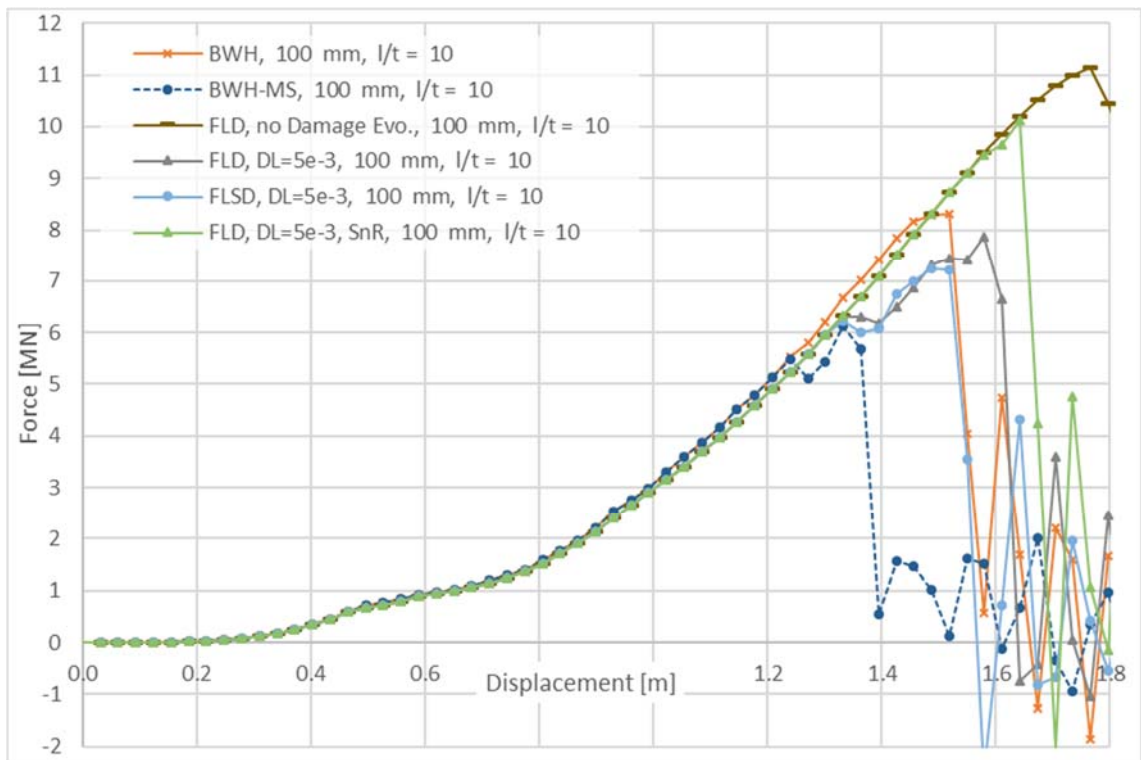

> Figure B-6 Comparison between BWH, FLD and FLSD. Mesh size 100 mm.

Both the FLD and FLSD material with Swift instability predict fracture at approximately the same level as the BWH model without mesh scaling. The FLD material with Store and Rice bifurcation model predict fracture at a higher force level.

3 ELEMENT TYPES AND INTEGRATION POINTS

To optimize the analysis time it is chosen to use elements with reduced integration and three integration points over the element thickness. Sensitivity studies are performed to study the effect of these choices. The results are presented in Figure B-7.

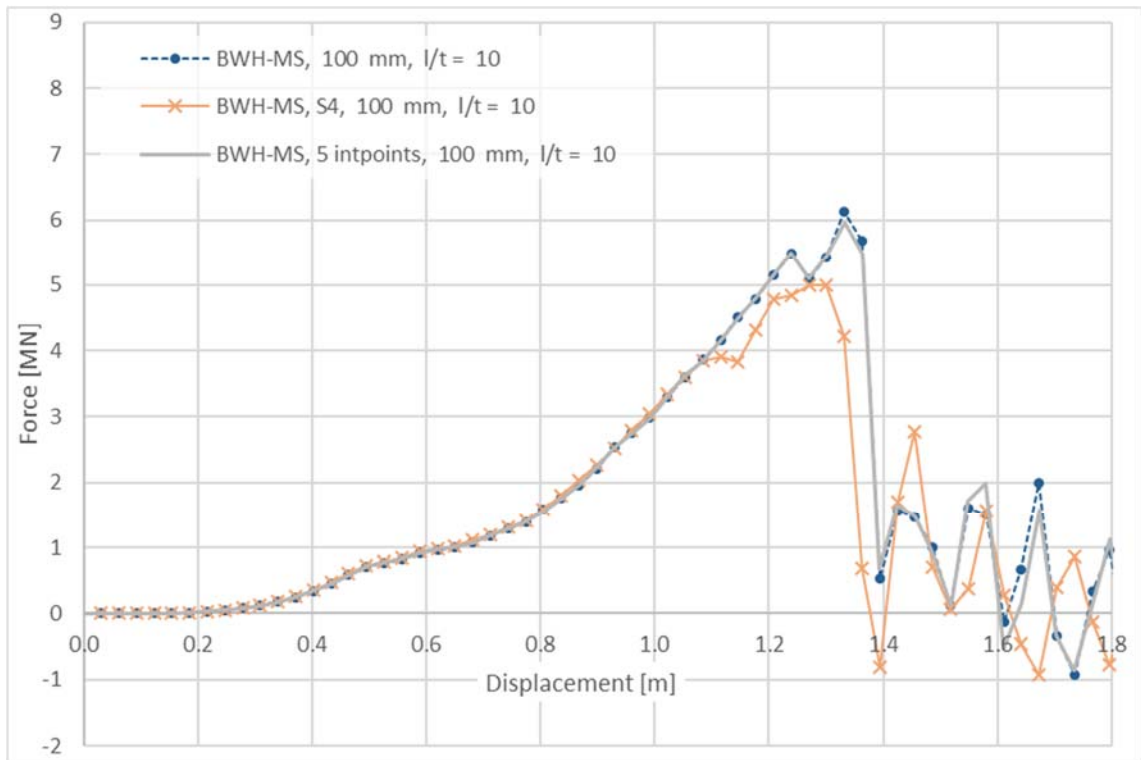

> Figure B-7 Sensitivity study of element formulations

It is seen from the force-displacement curves in Figure B-7 the difference in force level at fracture is small when comparing three integration points over the thickness with five points. This is expected for the BWH model. The model defined so that instability in the middle integration point give the same damage for the whole element.

Analysis with reduced integration give a stiffer response than the analysis with full integration. The reason for this is believed to be that the element control such as hourglass control may add additional stiffness to the elements. Artificial energy should therefore be studied in the full analysis.

4 REFERENCES

- [1] DNVGL-RP-C208, "Determination of structural capacity by non-linear finite element analysis methods," DNV GL, 2016.
- [2] Simulia, "Abaqus/CAE 2017," Dassault Systèmes, 2016.
- [3] T. B. Stoughton and X. Zhu, "Review of theoretical models of the strain-based FLD and their relevance to the stress-based FLD," *International Journal of Plasticity*, vol. 20, pp. 1463-1486, 2004.
- [4] SBJ-33-C5-OON-22-RE-015-B, "Concept development floating bridge E39 Bjørnafjorden - K12 - Ship impact, Bridge girder," Norconsult, Dr. Techn. Olav Olsen, 2019.