



Statens vegvesen

Norwegian Public Roads
Administration

General specifications 2

Standard specification texts for bridges and quays

Principal specification 8

Manual

Handbook 026E

026E

March 2009



Statens vegvesen

Norwegian Public Roads
Administration

Handbook 026

General Specifications 2

Standard specification texts for bridges and quays

Principal specification 8

2009

March 2009

Norwegian Public Roads Administration Handbooks

This is one of a series of handbooks prepared and issued by The Norwegian Public Roads Administration - a collection of consecutively numbered books which primarily are written for use within the Administration.

This English version is a translation of the Norwegian text. In case of linguistic differences between the two versions, the Norwegian version is the valid one.

The books are for sale and may be ordered from the Directorate of Public Roads at prices given in the book-list - Handbook no. 022. Preparing and updating the books are a responsibility of the Directorate of Public Roads.

The Graphic Division within the Administration Department is generally responsible for designing and printing the books.

Handbooks are also available in digital form on the following web-site:
www.vegvesen.no/Fag/Publikasjoner/Handboker
Some handbooks are only available in digital form on this web site.

The handbooks are issued on two levels:
Level 1: Yellow band on the cover indicates Regulations, Standards and Guidelines approved by the authority responsible or The Directorate of Public Roads with authorisation.

Level 2: Blue band on the cover indicates Instructions, Teaching Manuals and Road Data approved by individual departments authorised by the Directorate of Public Roads.

Standard specification texts for bridges and quays
No. 026 in the series of handbooks
Design: Graphic Division NPRA
Issued: Only available in digital form – see web site above

ISBN 978-82-7207-620-6

Preface English edition

This is a translation of handbook 026, November 2007 edition. All reasonable measures have been taken to ensure the accuracy of this translation, but no responsibility will be accepted for error, omission or inaccuracy.

In cases of doubt or dispute, the original Norwegian text only is valid.

This English translation is therefore not to be referred to as a contract document.

Denne er en oversettelse av håndbok 026, november 2007-utgaven. Alle rimelige foranstaltninger er tatt for å sikre nøyaktigheten i oversettelsen, men ansvar vil ikke bli akseptert for feil, uteglemler eller unøyaktighet.

Ved eventuell tvil eller uenighet, er bare den norske teksten gyldig.

Det skal derfor ikke henvises til den engelske utgaven som et kontraktsdokument

Directorate of Public Roads
Oslo, March 2009
Responsible department:
Road Development Department/Technology Department

Foreword

This edition of General Specifications 2 replaces the edition of 1997.

The main objectives of the 2007 update have been:

- to take new technical solutions into account
- to update in relation to revised handbooks and standards
- to take necessary account of the fact that all work is now carried out through contracts
- to come more closely into line with NS 3420 Specification texts for building, construction and installations, where appropriate (within the existing structure of the General Specifications).

The intention of coming more closely into line with NS 3420, partly with a view to making measurement rules as similar as possible, has been accomplished to some extent. In order to bring about alignment with NS 3420 for structures at specification level, the letters d) and e) have switched contents, and x) replaces f). The General Specifications measurement rules have been evaluated against NS 3420. In a number of cases the measurement rules have been changed, but this has not been done consistently.

As a result of changes in standards for concrete works, designations for materials have been updated with respect to strength class, durability class etc.

References to standards and handbooks have been updated for all specifications as far as possible.

All embedded detail has been collected in Specification 84 Concrete.

The materials section of Specification 85 Steel has been substantially revised. The same applies to the section on surface treatment of steel structures.

The contents of Specification 86 have been changed. It has become an umbrella specification for collecting together materials other than concrete and steel, and has been called Specification 86, Wood, stone and aluminium.

The contents of Specification 87 have also been changed. It has become an umbrella specification for equipment and special work that do not belong in the other specifications. It has been given the name Specification 87 Bridge surfacing, equipment and special work.

In the previous version, bridges and quays each had their own operations and maintenance specifications. These have now been combined into a specification called Specification 88 Inspection, operations and maintenance. The operations and maintenance specifications associated with function agreements are also undergoing evaluation. Specification 88.8 has therefore been reserved for "other operations and maintenance".

The digit 9 is being reserved as previously for "Other works" additional to those specified in the General Specifications. Specifications where it may be relevant to use the 9 are not shown in the printed version, but added as needed.

General Specifications 2 now contains only specifications that are used in contracts.

In conclusion it should be mentioned that the Component Code to be used in the tender documents for new structures has been substantially simplified and reduced in size.

Directorate of Public Roads
Oslo, November 2007
Responsible department:
Road Development Department/Technology Department

Contents

Foreword	5
Contents	7
Introduction.....	9
1. Areas of application of the general specifications.....	9
2. Structure and editing of the general specifications.....	9
2.1 Principal specifications.....	9
2.2 Subdivision principles	9
2.3 General structure	10
2.4 Use of special digits	10
3. Place and component code	10
4. Use of the general specifications in tendering	11
4.1 Tender documents	11
4.2 Departures from/supplements to the general specifications.....	11
4.3 Pricing and measurement rules.....	11
4.4 Methods of execution.....	11
4.5 Inspections.....	12
5. Hierarchical structure of specifications	12
6. Relationship with other documents	12
7. Quantity specifications.....	12
7.1 Terms.....	12
7.2 Definitions for basis for quantity surveying.....	13
7.3 Definitions of state	13
8. Use of the general specifications as a basis for registering costs	13
9. Units	13
10. Terminology.....	14
11. List of specifications.....	15
12. Specifications with explanation	21
13. Component code with explanation	269
13.1 The place and component code.....	269
13.2 Relationship between the component code and The general specifications	269
13.3 Complete component code for tender documents	269
13.4 Expanded component code.....	271

Introduction

1. AREAS OF APPLICATION OF THE GENERAL SPECIFICATIONS

The General Specifications cover construction work, operations and maintenance work, and are to be used in work carried out by the Norwegian Public Roads Administration through contracts.

They shall provide uniform rules for the execution, inspection and quantity surveying of work of the same type. It shall facilitate the work of preparing conditions for tenders. This will also make it far simpler for contractors to price the work, because the scope and requirements for the individual piece of work will be the same from one tender to the next and be specified in a standardized, recognised text.

2. STRUCTURE AND EDITING OF THE GENERAL SPECIFICATIONS

2.1 PRINCIPAL SPECIFICATIONS

The General Specifications are hierarchically structured according to the decimal system. Related general specifications are broken down into ten groups called Principal Specifications, which are numbered from 0 to 9:

Principal Specification 0:	For internal use
Principal Specification 1:	Preparatory measures and general costs
Principal Specification 2:	Blasting and earthworks
Principal Specification 3:	Tunnels
Principal Specification 4:	Ditches, manholes and ducts
Principal Specification 5:	Road foundation
Principal Specification 6:	Road surfacing
Principal Specification 7:	Road equipment and environmental measures
Principal Specification 8:	Bridges and quays
Principal Specification 9:	For use in operations and maintenance

Each Principal Specification is subdivided into specifications through the addition of one or more digits after the Principal Specification number. The General Specifications are divided into levels depending on the number of digits designating the specifications. High level specifications have few digits, while low level specifications have many digits. The General Specifications are constructed so as to allow free choice of the level of detail for description and cost follow-up in the individual case.

2.2 SUBDIVISION PRINCIPLES

The general principles for subdivision of a specification are either that

- A All sub-specifications together constitute the specification at the level above or
- B The sub-specifications are more precisely defined optional variants of the specification at the level above.

An example of subdivision according to principle A (sub-products):

Table 2.2-1 (026)			
84.37 Tension reinforcement			
84.371 Delivery and installation of tension reinforcement including accessories	84.372 Tensioning of tension reinforcement	84.373 Temporary frost and corrosion protection of tension reinforcement	84.374 Grouting of tension cable duct

An example of subdivision according to principle B (optional variants):

Table 2.2-2 (026)			
84.21 Plane formwork above water			
84.212 Plane formwork with panels (visible surfaces)	84.213 Plane formwork with boards (visible surfaces)	84.214 Plane, profiled wooden for- mwork	84.215 Plane formwork with pat- terned matrices

In a number of cases, specifications at a particular level are subdivided according to both principle A and B simultaneously. In other words, some of the underlying specifications are sub-products, and some are optional variants of these sub-products.

2.3 GENERAL STRUCTURE

The texts specifying the specifications are arranged according to the following general structure:

- a) Scope
- b) Materials
- c) Execution
- d) Tolerances
- e) Testing, inspection
- x) Quantity rules

Any of the points a) – x) in the individual specifications may be supplemented by drawings and/or special specifications.

There are a few specifications where supplementary details are added under all these points.

2.4 USE OF SPECIAL DIGITS

The use of the number 9 as 2nd or higher digit is reserved for “other works”, i.e. other than those specified with the same number of digits. In other words, specification numbers ending in 9 are used for works that are necessary for achieving a complete product, but for which a separate specification is not defined (Subdivision principle A). Similarly, specification numbers ending in 9 are used for options other than those that are allocated a separate specification number (Subdivision principle B).

Specifications where it may be relevant to use the number 9 are not shown in the printed version, but added as needed. Examples of use of the number 9 are shown below.

Example: If formwork is to be of a type other than those covered by Specifications 84.211-215, it can be specified by means of Specification 84.219.

3. PLACE AND COMPONENT CODE

The tender documents are normally broken down according to specification.

In large projects, a place code may also be used to define where the works are to be executed, for example different bridges, roads or tunnels.

For bridge works, a component code may also be used to specify a subdivision of place. Element may be abutments, columns etc.

Example: BB-C2 (Place: Bråten Bridge – Element: piers)

For work on bridges and quays, details of standardized component codes A-H are specified in Chapter 13.

4. USE OF THE GENERAL SPECIFICATIONS IN TENDERING

4.1 TENDER DOCUMENTS

In connection with tendering, the General Specifications will form a part of the tender documents, normally as Chapter D1 according to Handbook 066 **Tender documents**:

D1. Description and bill of quantities

The description and bill of quantities shall be prepared in accordance with "General Specifications 1. Standard specification texts for road contracts" (Handbook 025) and "General Specifications 2. Standard specification texts for bridges and quays" (Handbook 026), unless otherwise decided.

Chapter D1 shall include or refer to the individual specifications in the General Specifications.

4.2 DEPARTURES FROM/SUPPLEMENTS TO THE GENERAL SPECIFICATIONS

In connection with a number of specifications, it will be necessary to specify where the work is to be carried out, and it may be necessary to have technical descriptions which depend on local conditions/design criteria, and which therefore cannot be standardized. Chapter D1 "Description and bill of quantities" is to be supplemented as needed by special specifications which will include additions, exceptions and changes in relation to the formulations in the General Specifications.

4.3 PRICING AND MEASUREMENT RULES

Unit prices for each specification shall normally cover all costs that are necessary for delivering the work in accordance with the requirements in the tender documents. Unit prices shall cover:

- materials and accessories
- wages
- social expenses
- transport
- temporary storage
- equipment, tools, machinery
- scaffolding and temporary installations
- administration and earnings margin
- safety measures
- required documentation
- declaration(s) of compliance with relevant documentation

unless these costs are specified separately in separate specifications.

Settlement shall take place according to the measurement rules given under point x) in the respective specifications. When the measuring rules specify settlement according to planned quantities, and the preconditions for quantity calculations change because of conditions over which the contractor for the works in question has no control, the design basis is assumed to be adjusted, and changed planned quantities recorded. Together with the specified unit prices the changed planned quantities constitute the basis for the settlement (see provisions of the contract).

4.4 METHODS OF EXECUTION

The work shall be carried out in compliance with current Norwegian legislation, public regulations and rules. The Contractor must himself evaluate the methods and safety of the execution, independently of measuring rules etc.

In connection with a number of specifications, the contractor shall present his plans for the execution of the work to the Project Owner. As a general rule:

- if the contractor wishes to use other methods of execution than those specified, he must obtain the consent of the Project Owner, and must himself cover any extra costs entailed by his method of execution.
- the Project Owner's consent to or approval of the Contractor's plans does not exempt the Contractor from responsibility.

4.5 INSPECTIONS

Requirements with respect to inspection of materials and execution are specified in the provisions of the contract, Handbook 066 Tender documents and in the General Specifications, Specification 11.4. In the General Specifications, point d) of the respective specifications indicates the tolerances that are to apply, and point e) what testing/inspection is to be carried out during stable operations.

Tolerances shall not be exploited one-sidedly. See current standards and guidelines for the proportion of accepted deviations from tolerance requirements. 'Stable operations' means that work proceeds in the normal, intended manner, and that there is therefore no reason to suspect deviations from specifications. Separate inspection instructions may also be issued and/or supplements to the inspection required in the documents mentioned above, in *the special specifications* or in special contract provisions.

5. HIERARCHICAL STRUCTURE OF SPECIFICATIONS

Each digit in the specification number has a distinct meaning. For example:

8:	Bridges and quays
84:	Concrete
84.2:	Formwork
84.21:	Plane formwork above water
84.212:	Plane formwork with panels (visible surfaces)

Requirements regarding materials, the execution of the work, inspections and tolerances specified at a higher level also apply to a subordinate level. However, the scope of the work described in a higher specification does not apply to the subordinate specification if there is further text specifying scope.

For example: the provisions applying to Specification 84.372 "Tensioning of tension reinforcement" consist of the texts specified under Specifications 84.372, 84.37, 84.3 and 84. However, this does not apply to the scope of the specification. Specification 84.372 covers only tensioning of tension reinforcement, even though the higher-level specification 84.37 covers much more, such as grouting, frost protection etc.

6. RELATIONSHIP WITH OTHER DOCUMENTS

The General Specifications constitute a technical descriptive document and take precedence over the documents to which reference is made in the General Specifications, unless otherwise decided. The documents to which reference is made can be classified into two groups:

- Norwegian Standards
- Norms, codes of practice and guidelines

The General Specifications are not concerned with criteria for choice of solutions (textbook material), but only with descriptions of the work that is to be carried out. In any cases where the General Specifications lack or contain inadequate descriptions, the relevant provisions/recommendations in the documents to which reference is made in the technical description shall apply.

7. QUANTITY SPECIFICATIONS

*(Norwegian abbreviations are used in the following text.)

7.1 TERMS

The following terms are used:

Basis for quantity surveying	Condition		
	In-place	Loose	Deposited
Planned	(pf) *		(pa) *
Completed	(uf) *	(ul) *	(ua) *

7.2 DEFINITIONS FOR BASIS FOR QUANTITY SURVEYING

Planned quantity (p)*

is the quantity within the measurement limits forming the basis for execution of the work.

Completed quantity (u)*

is the actual quantity within the measurement limits of the finished product after execution.

7.3 DEFINITIONS OF STATE

In place (f)*

is the state the materials are in before ripping or loading.

Loose (l)*

is the state the materials are in after loading on a means of transport, before transport. This also applies to transport in a loader or excavator bucket or similar.

Deposited (a)*

is the condition the materials are in when they have been deposited and processed.

8. USE OF THE GENERAL SPECIFICATIONS AS A BASIS FOR REGISTERING COSTS

A restrictive practice shall be conducted with respect to giving specifications content other than the standardized content. Departure from the standardized content will make any cost statistics less accurate. Subdivision of specifications that deviate in any way from the standardized specifications should therefore be avoided. The use of '9' as the last digit in the code number should be considered for options that deviate from the standardized solutions.

There may be doubt as to which specification number should be used in connection with a particular piece of work. In such cases, the recommendation is to begin 'looking from above' in the hierarchy according to which the General Specifications are structured.

The level of detail to which the work should be broken down (i.e. how many digits should be used) will be a compromise between the need for and interest in the data that are recorded as a result, and how precisely the processes can be recorded in practice. In cost recording and follow-up it will be natural to use fewer digits and less detail than in the tender documents.

9. UNITS

Norwegian Standard 1024 generally applies to the use of units. The following basic units apply in SI (Système International d'Unités – the international unit system):

Parameter	Basic unit	
	Name	Symbol
Length	Metre	m
Mass	Kilogram	kg
Time	Second	s
Electricity	Ampere	A
Light intensity	Candela	Cd

The following units have been derived from these basic parameters and given separate names.

Parameter	Derived unit		
	Name	Symbol	Derived from
Power	Newton	N	kgm s ⁻²
Frequency	Hertz	Hz	s ⁻²
Pressure, tension	Pascal	Pa	N/m ²
Energy, work, heat	Joule	J	Nm
Power	Watt	W	J/s

Among other units that can be used with SI units because of their general practical importance are:

Parameter	Unit	
	Name	Symbol
Time	Minute	Min
	Hour	h
	Day	d
Angle	Degree (angle)	° / g
	Minute (angle)	'
	Second (angle)	"
Volume	Litre	L
Mass	Ton	T
Temperature	Celsius	°C

10. TERMINOLOGY

For Principal Specifications 1 to 7 and 9, see General Specifications 1, Introduction, Section 10.
For Principal Specification 8, see Norwegian Standards.

11. LIST OF SPECIFICATIONS

PRINCIPAL SPECIFICATION 8: BRIDGES AND QUAYS

81	Soils	21
81.1	Excavation work above water.....	21
81.11	Rigging for excavations above water	22
81.12	Excavation of soils in unbraced construction pit above water.....	22
81.13	Excavation of soils in braced construction pit above water	22
81.14	Excavation of blasted rock in unbraced construction pit above water	22
81.15	Excavation of blasted rock in braced construction pit above water	23
81.16	Supplement for loosening of hard material in unbraced and braced construction pits above water.....	23
81.17	Supplement for excavating in unbraced and braced construction pits with piles above water	23
81.18	De-watering of construction pits, water inconveniences	23
81.2	Scaling above water	23
81.21	Levelling and scaling to undisturbed ground in soils, construction sites above water	23
81.22	Scaling of exposed rock, construction pits above water.....	23
81.23	Rough scaling of blasted rock surface, construction pits above water.....	23
81.24	Fine scaling of blasted rock surface, construction pits above water.....	23
81.25	Wedge scaling of blasted and fine-scaled rock surface, construction pits above water ...	24
81.3	Excavation below water.....	24
81.31	Rigging for excavation work below water	25
81.32	Excavation of soils in unbraced or braced construction pit below water.....	25
81.34	Excavation of blasted rock in unbraced or braced construction pits below water.....	25
81.36	Supplement for loosening of hard material in unbraced or braced construction pits below water	25
81.37	Supplement for excavating in unbraced or braced construction pits with piles below water	26
81.4	Scaling below water.....	26
81.41	Levelling and scaling to undisturbed ground in soils, construction pits below water	26
81.42	Scaling to exposed rock, construction pits below water.....	26
81.43	Rough scaling of blasted rock surface, construction pits below water.....	26
81.44	Fine scaling of blasted rock surface, construction pits below water.....	26
81.45	Wedge scaling of blasted and fine-scaled rock surface, construction pits below water ...	26
81.5	Transport of soil	26
81.51	Transport on land	26
81.52	Levelling of dump/depot.....	27
81.53	Transport by water	27
81.54	Transfer of soils and blasted rock	27
81.6	Placement of material above water	27
81.61	Placement of local materials.....	27
81.62	Delivery and placement of materials	28
81.63	Material placed against structures.....	28
81.7	Placement of material below water.....	29
81.71	Rigging for placement of material below water	29
81.72	Placement/filling of local materials below water.....	29
81.73	Delivery and placement of material below water	30
81.74	Material against structures below water.....	30
82	ROCK	31
82.1	Blasting/demolition above water.....	31
82.11	Rigging for blasting above water	31
82.12	Blasting above water	31
82.14	Demolition of boulders above water.....	31
82.15	Rigging for further blasting above water	31
82.2	Blasting/demolition below water.....	31
82.21	Rigging for blasting/demolition below water.....	31
82.22	Blasting below water	32
82.24	Demolition of boulders below water	32
82.25	Rigging for further blasting below water	32
82.3	Isolation of aggressive rock	32
82.4	Drilling holes and core drilling.....	32

	82.41	Drilling holes in rock and concrete	32
	82.42	Core drilling in rock and concrete	33
83		SUBSURFACE STRUCTURES (PILES, SHEET PILES ETC.)	34
	83.1	Concrete piles	35
	83.11	Preparatory and general works	35
	83.12	Delivery of concrete piles and accessories	36
	83.13	Rigging and positioning for concrete piles	38
	83.14	Driving of concrete piles	39
	83.15	Testing and control	42
	83.16	Waiting time and operating time	43
	83.17	Completing works	43
	83.2	Steel pipe piles (driven and drilled)	43
	83.21	Preparatory and general works	44
	83.22	Delivery of steel pipe piles and accessories	45
	83.23	Rigging and positioning for steel pipe piles.....	46
	83.24	Driving/drilling of steel pipe piles	47
	83.25	Testing and inspection	51
	83.26	Waiting time and operating time	52
	83.27	Completing works	53
	83.28	Reinforcing and casting of concrete for steel pipe piles	53
	83.3	Solid steel piles (steel sections).....	53
	83.31	Preparatory and general works	53
	83.32	Delivery of steel piles and accessories.....	54
	83.33	Rigging and positioning of steel piles	55
	83.34	Driving of steel pipe piles	56
	83.35	Testing and inspection	59
	83.36	Waiting time and operating time	60
	83.37	Completion works	60
	83.4	Cast in place piles (bored piles and excavated piles)	60
	83.41	Preparatory and general works	60
	83.42	Bored piles	62
	83.43	Transportation of excavated materials from shaft.....	63
	83.44	Pile footing	63
	83.45	Reinforcement and accessories in bored piles.....	65
	83.46	Casting of bored piles	66
	83.47	Testing and inspection	66
	83.48	Waiting time and operating time	67
	83.5	Steel core piles.....	67
	83.51	Preparatory and general works	67
	83.52	Rigging and positioning for steel core piles.....	68
	83.53	Drilling for steel core piles.....	69
	83.54	Grouting of borehole in rock	70
	83.55	Installation of steel core piles	71
	83.56	Testing and monitoring	73
	83.57	Waiting time and operating time	74
	83.6	Sheet piles and bracing systems	75
	83.61	Steel sheet piles	75
	83.62	Wooden sheet piles.....	81
	83.63	Stop logs (Berliner-Wand)	81
	83.64	Other types of retaining walls.....	81
	83.65	Internal bracings and shoring of sheet pile/retaining walls	81
	83.66	Cushions for anchored and internally braced sheet piles/retaining walls	82
	83.7	Anchoring and bolts in rock and soils for structures	82
	83.71	Anchoring in rock	83
	83.72	Anchoring in soils.....	90
	83.73	Suitability tests for anchorings in soils.....	94
	83.74	Completing works for anchorings.....	94
	83.75	Removal of temporary anchorings.....	94
	83.76	Special anchoring works	95
	83.77	Grouted bolts in rock	95
	83.8	Slurry trench walls.....	96
	83.81	Rigging and positioning of slurry trench walls	96
	83.82	Excavations and slurry for slurry trench walls	96
	83.83	Rock footing for slurry trench walls.....	96

	83.84	Reinforcement for slurry trench wall.....	96
	83.85	Concrete.....	96
	83.86	Additional costs for extensive additional concrete consumption	96
84		CONCRETE	97
	84.1	Scaffolding, temporary bracing and temporary cover.....	98
	84.11	Foundations for scaffolding	99
	84.12	Bracing scaffolding for vertical and sloping structural components (pillars, columns, towers etc.)	99
	84.13	Load-bearing scaffolding erected directly from the ground.....	99
	84.14	Cantilever scaffolding	99
	84.15	Rigging/de-rigging of cantilever carriages	100
	84.16	Bracing of structure during the construction period	101
	84.17	Temporary support, support columns	101
	84.18	Temporary cover (tent)	101
	84.2	Formwork	101
	84.21	Plane formwork above water.....	103
	84.22	One-sided wall formwork above water	103
	84.23	Curved formwork above water	103
	84.25	Special formwork	104
	84.26	Supplement for formwork for special structural details.....	105
	84.27	Execution details	106
	84.28	Formwork below water	107
	84.3	Reinforcement.....	107
	84.31	Ribbed reinforcing bars B500NC	108
	84.32	Reinforcement, special grades.....	108
	84.33	Welded reinforcement mesh and reinforcement units.....	109
	84.34	Special splicing devices for reinforcement.....	109
	84.35	Supplement for special solutions	109
	84.36	Free.....	110
	84.37	Prestressing steel	110
	84.38	Prestressing bars and special prestressing steel.....	112
	84.4	Concreting	112
	84.41	Concreting above water, normal-weight concrete	117
	84.42	Concreting above water, lightweight aggregate concrete	118
	84.43	Underwater casting	118
	84.44	Concrete surface course	120
	84.45	Prepacked concrete	121
	84.46	Sprayed concrete	121
	84.5	Treatment of fresh and curing concrete	121
	84.51	Screeding and trimming of concrete surface	121
	84.52	Screeding and finishing of bridge deck	121
	84.53	Exposure of aggregate by high-pressure hosing.....	123
	84.54	Curing measures	123
	84.55	Heat insulation of concrete	125
	84.56	Heat insulation of metal surfaces against which concrete is cast	125
	84.57	Cooling of concrete	125
	84.58	Heating of adjoining structural components	126
	84.6	Mechanical treatment of cured concrete	126
	84.61	Exposure of coarse aggregate at the concrete surface.....	126
	84.62	Cleaning of concrete surface, dry methods	126
	84.63	Cleaning of concrete surface, wet methods	126
	84.64	Chiselling of concrete surface	127
	84.66	Hammerdressing of concrete surface	127
	84.67	Grinding of the concrete surface	127
	84.68	Milling of concrete surface	127
	84.7	Concrete elements ready for assembly	127
	84.71	Delivery and assembly of beam and slab elements	127
	84.72	Delivery and assembly of deck components	127
	84.73	Edge elements	128
	84.74	Culvert elements	128
	84.75	Column elements	128
	84.76	Delivery and assembly of foundation elements	128
	84.77	Delivery and assembly of deck components for beam/girder bridges	128

84.8	Gluing, surface treatment and accessories	128
84.81	Gluing with epoxy	128
84.82	Gluing with cement slurry	129
84.83	Surface treatment of concrete	129
84.84	Waterproofing products for construction joints	129
84.85	Joints in concrete	130
84.86	Embedded parts, threaded casings, bolts etc.	131
84.87	Embedding in recesses, grouting etc.	131
85	STEEL.....	132
85.1	Delivery of steel materials	133
85.11	Delivery of rolled steel and filler metal for welding.....	134
85.12	Delivery of cast steel and cast iron.....	138
85.13	Delivery of bolts including nuts and washers.....	138
85.14	Delivery of bolt studs	139
85.2	Tooling, machining and assembly of steel parts	139
85.21	Preparations for fabrication	147
85.22	Tooling and machining of materials	147
85.23	Assembly of steel parts.....	148
85.24	Welding	148
85.25	Bolted connections	153
85.26	Partial trial assembly	156
85.3	Surface treatment of steel structures.....	156
85.31	Qualification of work procedures	159
85.32	Degreasing and washing	160
85.33	Blast cleaning.....	160
85.34	Metallizing.....	160
85.35	Application of paint/organic coatings	162
85.36	Powder coating	162
85.37	Pre-treatment of steel bridge decks.....	163
85.4	Transport and erection of steel structures.....	163
85.41	Transport of steel structures	164
85.42	Erection of steel structures	164
85.43	Surface treatment after erection	165
85.5	Delivery and assembly of steel structural elements	166
85.52	Delivery and installation of gratings.....	166
85.53	Delivery and assembly of saddles and anchorages for cables	166
85.54	Culverts of steel pipe, light opening L > 2.5 m.....	167
85.6	Delivery of bridge cables	167
85.7	Transport and installation of cables.....	167
85.71	Transport of cables	168
85.72	Rigging for installation of cables	168
85.73	Cable installation.....	168
85.74	Cable adjustment	168
85.75	Surface treatment of cables.....	168
86	WOOD, STONE, ALUMINIUM ETC.....	169
86.1	Wood	169
86.11	Delivery of materials for timber structures.....	169
86.12	Working of structures and structural components of wood	170
86.13	Preservation of timber structures.....	170
86.14	Transport, storage and assembly of timber structures.....	172
86.2	Stone	176
86.21	Scaffolding for stone vaults.....	176
86.22	Formwork for stone arches.....	176
86.23	Delivery of stone	176
86.24	Building stone vaults and stone walls.....	176
86.25	Fill	177
86.26	Delivery and laying of kerbstones.....	177
86.27	Delivery and laying of facing stone	177
86.28	Delivery and mounting of stone baskets	177
86.3	Aluminium	177

87	BRIDGE SURFACING, EQUIPMENT AND SPECIAL WORK	178
87.1	Waterproofing, surface course, expansion joint nosings and asphalt joints.....	178
87.11	Temporary cover and climate control	179
87.12	Tack coat for surfacing class A1	180
87.13	Simplified waterproofing – A2	180
87.14	Full waterproofing – A3.....	181
87.15	Levelling layer, binder course and asphalt surface course.....	185
87.16	Connections	187
87.17	Crack inducing joints and asphalt joints.....	190
87.18	Expansion joint nosings.....	191
87.2	Parapets	192
87.21	Detailed engineering	195
87.22	Vehicle-proof steel parapet	195
87.23	Steel top parapet.....	195
87.24	Steel pedestrian guardrail	195
87.25	Parapets of concrete, aluminium and timber.....	195
87.26	Barriers.....	196
87.27	Parapet details.....	196
87.28	Safety fences.....	196
87.3	Bridge bearings	196
87.31	Deformation bearings (block bearings).....	197
87.32	Fixed bearings.....	197
87.33	Free/multidirectional sliding bearings	197
87.34	Guided/unidirectional sliding bearings.....	197
87.35	Roller bearings.....	197
87.36	Cylindrical bearings.....	197
87.37	Spherical bearings	197
87.4	Joint structures	197
87.41	Finger joints.....	200
87.42	Multi-element joints.....	200
87.43	Other joint types	200
87.44	Supplement, noise-reducing measures	200
87.45	Supplement, gearing to pedestrian and cycle traffic.....	200
87.46	End edges and passages.....	200
87.47	Water runoff system.....	201
87.5	Water drainage and other pipe systems.....	201
87.51	Simple water drains.....	201
87.52	Adjustable drain	201
87.53	Sand traps	202
87.54	Drainage system.....	202
87.55	Other pipe systems	202
87.6	Electrical installations	202
87.61	Electrical installations.....	203
87.62	Lighting.....	203
87.63	Special electrical equipment for ferry terminals	204
87.64	Power supply	204
87.65	Control and monitoring systems	204
87.66	Anodes for cathodic protection.....	205
87.67	Surge protection.....	205
87.7	Mechanical equipment.....	205
87.71	Hydraulic equipment.....	206
87.72	Pumps.....	206
87.73	Dehumidifying systems	206
87.74	Emergency power generators.....	206
87.75	Permanent movable access equipment.....	207
87.76	Barriers	207
87.8	Other equipment	207
87.81	Vibration dampers and fendering.....	208
87.82	Reference points.....	208
87.83	Installed access equipment	208
87.84	Equipment and service buildings.....	209
87.85	Equipment for buildings	209
87.86	Decoration	210
87.87	Special equipment for ferry terminals	210
87.88	Signs	210

88	INSPECTION, OPERATIONS AND MAINTENANCE	211
88.1	Inspections	211
88.11	Rigging, access equipment and scaffolding	211
88.12	Final inspection/claims inspection	211
88.13	General supervision and temporary securing	211
88.14	Basic inspection	212
88.15	General inspection	212
88.16	Special inspection	212
88.17	Measuring/material investigations	212
88.18	Instrumented monitoring	215
88.2	Operation and groundworks	216
88.21	Rigging and access equipment	216
88.22	Cleaning	216
88.23	Clearing/cleaning up	217
88.24	Expenses for operation of bridges and ferry terminals	217
88.25	Inspection/service of electrical equipment and machinery	217
88.26	Earthworks	218
88.3	Concrete works	219
88.31	Rigging, scaffolding and shielding	219
88.32	Mechanical repairs	220
88.33	Repairs below water	230
88.34	Repair of fissures and cracks	231
88.35	Re-alkalising/chloride extraction	232
88.36	Cathodic protection	233
88.37	Surface treatment of concrete	234
88.38	Other maintenance of concrete	238
88.4	Steel works	238
88.41	Rigging, scaffolding and protection	238
88.42	Inspection	238
88.43	Maintenance of steel	239
88.44	Replacement of steel	240
88.45	Maintenance of connectors	240
88.46	Maintenance of bridge cables	241
88.47	Maintenance of hangers	241
88.48	Surface treatment of steel	241
88.5	Timber, stone and aluminium work	245
88.51	Rigging, scaffolding and protection	245
88.52	Wood maintenance	246
88.53	Protection of timber structures	246
88.54	Maintenance of stone	247
88.55	Maintenance of aluminium	248
88.56	Surface treatment of aluminium	248
88.6	Waterproofing and surface course work	248
88.61	Rigging, protection and temporary cover	248
88.62	Grinding, milling and removal of waterproofing and surface course	249
88.63	Groove filling/patching of surface course	251
88.64	Waterproofing	251
88.65	Levelling layer, binder course and asphalt surface course	253
88.66	Connections	253
88.67	Concrete surface course	255
88.68	Timber surface course	255
88.7	Equipment	255
88.71	Rigging and scaffolding	256
88.72	Maintenance, replacement and reinstallation of parapets	256
88.73	Maintenance of bridge bearings	259
88.74	Maintenance of joint structures	260
88.75	Maintenance of water runoff and other pipe systems	261
88.76	Maintenance of electrical installations and machinery	261
88.77	Maintenance of other equipment	266
88.8	Available for other operations and maintenance	267

12. SPECIFICATIONS WITH EXPLANATION

8 BRIDGES AND QUAYS

81 SOILS

- a) Comprises any delivery of and all work with soils, blasted rock and demolished blocks to establish fully levelled construction pits and to set up embankments, slopes, erosion protection etc. in connection with bridges and quays.

The work is regarded as carried out above or below water, depending on where it takes place in relation to the water-table. This water-table is defined as the mean water level (MW) for the sea, the lowest regulated water level (LRW) for rivers and lakes that are regulated, and the low water level (LW) for rivers and lakes that are not regulated. The concept 'water-table' as used in Principal Specification 8 is a theoretical water-table, and not the physical water-table that may be encountered when the work is carried out. Costs associated with the difference between the theoretical and physical water-table shall be calculated into the specification.

Work in or below the water-table is nevertheless regarded as being carried out above water if the water-table is intended to be lowered artificially below the level where the work takes place (drained construction pit).

Work with vegetation and topsoil is included in Specification 21.

Earthworks in connection with construction work may also be included in Principal Specification 2.

Filter layers, geotextile and frost insulation are included in Specification 52.

Vegetated areas and slopes above water are included in Specification 74.

- c) Excavation, filling, temporary storage of soils etc. shall be carried out in such a way that the stability of the area is not disturbed and avalanches and slides are not triggered. In potentially unstable areas, the contractor shall submit his assessment of the stability situation and his plan of execution to the Project Owner for comment before work begins. On request he shall also submit his plans for the user of materials and execution of earthworks to the Project Owner.

For ground conditions, access, transport distance, deposit areas and other conditions for execution, see *the special specifications* /geotechnical report. If conditions prove to deviate substantially from those specified/assumed to exist, the Project Owner shall be notified immediately.

If the bottom of the construction pit lies in soft clay or organic soil, the excavation must be carried out such that the bottom is not remoulded.

81.1 Excavation work above water

- a) Comprises excavation of soils, blasted rock and demolished blocks where excavation work is intended to be carried out above the water-table (dry or drained construction pit). Comprises rigging for excavation, excavation including loading or deposition of excavated material near the excavation site, excavation in construction pits with piles, mechanical scaling of exposed rock surface, levelling of the bottom of the construction pit plus necessary drainage of water or de-watering and maintenance of the construction pit.

Rocks with a volume of 1.0 to 10 m³ are regarded as boulders. Boulders larger than 10 m³ are regarded as solid rock.

Excavation of stones less than 1.0 m³ in size and demolished blocks is included in the specification. Demolition of boulders in soils is included in Specification 82.14.

- c) Even if drawings indicate where cables and pipes lie, their location on the site shall be indicated by suppliers of telecommunications and utilities and others who have infrastructure in the area where excavation is to take place, before work begins.

Work that affects this infrastructure shall be carried out in compliance with the owner's guidelines. The contractor shall also submit to such inspections as the owner in question finds necessary.

Excavation shall take place in such a manner that there is no risk of ground failure, so that the stability of the area is not disturbed and so that any surrounding structures, pile groups, bracing etc. are not damaged.

- d) Where the bottom of the excavation pit consists of soils, the maximum deviation from the planned height for a fully levelled bottom shall be ± 100 mm.

For permanent slopes, the permitted deviation from the planned profile is ± 0.15 m if they do not otherwise have deforming depressions or knobs.

- x) In braced construction pits, volume shall be calculated as planned surface measured internally within bracing/sheet piling multiplied by the height from the planned base of the construction pit or the water-table to ground level.

In an unbraced construction pit, volume is calculated as indicated below, unless otherwise specified.

For construction pits in soils, volume shall be calculated up to the slope plane that intersects the planned base level 0.75 m from the outside of the wall/column. If the wall/column has a sole/foundation, excavation is calculated as the distance beyond the sole/foundation as specified in the table below, but such that the total of the sole/foundation width and the excavation beyond is at least 0.75 m. Side slopes shall be calculated with a slope of 1:1 unless otherwise specified (see figure below). The distance from the structure to the slope must be assessed in the light of HES requirements, slope height/inclination and ground conditions. If the specified profile proves not to be stable, and the work has been carried out in compliance with the guidelines provided, calculation shall be based on necessary completed in-place volume.

For construction pits in rock, quantity shall be measured as planned in-place volume according to the blasting profile (cf. Specification 82.1). Calculations shall be based on vertical side surfaces with a distance from the excavation (blasting) line to the sole/foundation shutterings (b_2) as given in the table below, if the sides of the foundation are not intended to be cast directly against rock.

For construction pits in both soil and rock, soil excavation is calculated to 0.5 m beyond the blasting line. Side slopes are calculated as not having a foot that is lower than the foundation depth. (See figure).

Height (h) of sole/foundation	Excavation beyond sole/foundation (b_2)	
	Sole/foundation on soil	Sole/foundation on rock
Up to 0.5 m	0.30 m	0.50 m
0.5 – 1.0 m	0.50 m	0.75 m
Over 1.0 m	0.75 m	1.0 m

For columns and walls, $h > 1$ m and $b_2 = 0.75$ m for soils and 1.0 m for rock.

Excavation for any planned levelling layer below the foundation shall be included in the excavated soil without changing the location of the side slopes.

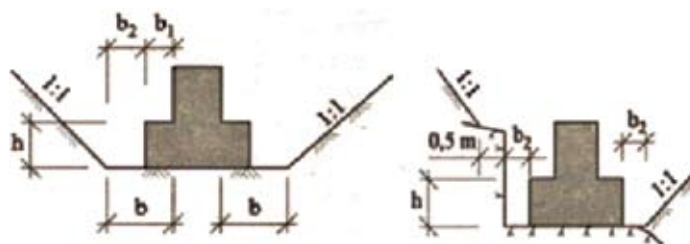

$$b = b_1 + b_2 \geq 0.75 \text{ m}$$

Quantity shall be measured as planned in-place volume. Unit: m^3

81.11 Rigging for excavations above water

- a) Comprises measures necessary to put excavating equipment into operational condition, for example access (if it is not included in Principal Specification 1), ground reinforcement / scaffolding etc. plus de-rigging and removal of equipment and temporary installations when the work has been completed.
- x) Costs shall be specified as a lump sum. Unit: LS

81.12 Excavation of soils in unbraced construction pit above water

- a) Comprises excavation of soils and demolished boulders with loading or deposition of excavated material near the excavation site. Also covers any special ripping, and draining/de-watering of construction pits up to 500 litres/minute, leading of water to approved outlets beyond the construction pit and necessary maintenance of the construction pit. De-watering requiring a higher pumping capacity than that mentioned above is included in Specification 81.18.
- x) Quantity shall be measured as planned in-place volume. See Specification 81.1. Unit: m^3

81.13 Excavation of soils in braced construction pit above water

- a) As in Specification 81.12. By braced construction pit is meant construction pits with side slopes that are not stable without special measures (sheet pile walls, bracing etc.), and where these measures place restrictions on the performance of the excavation work.

Drawbacks due to bracing, precautionary measures associated with excavation near the bracing and any removal of soil etc. from the bracings are regarded as included in the Specification.

Excavation in connection with bored piles and slurry trench walls is included in Specifications 83.413 and 83.8.

- x) Quantity shall be measured as planned in-place volume. The planned surface measured within the bracing/sheet piling is regarded as the base. Unit: m^3

81.14 Excavation of blasted rock in unbraced construction pit above water

- a) Comprises excavation of blasted rock. In other respects as in Specification 81.12.

- x) Quantity shall be measured as planned in-place volume according to blasting profile. See Specification 82.1. Unit: m³
- 81.15 Excavation of blasted rock in braced construction pit above water**
- a) Comprises excavation of blasted rock. Otherwise as in Specification 81.13.
- x) Quantity shall be measured as planned in-place volume according to blasting profile. See Specification 82.1. Unit: m³
- 81.16 Supplement for loosening of hard material in unbraced and braced construction pits above water**
- a) Comprises loosening of hard material. Excavation is included in Specification 81.12 or 81.13.
- c) The contractor shall carry out separate loosening (for example by blasting while complying with any restrictions that might be specified in *the special specifications*).
- x) Quantity shall be measured as planned in-place volume. See Specification 81.1. Unit: m³
- 81.17 Supplement for excavating in unbraced and braced construction pits with piles above water**
- a) Comprises extra costs associated with excavation in construction pits with piles.
- x) Quantity shall be measured as planned in-place volume. See Specification 81.12 and 81.13. Unit: m³
- 81.18 De-watering of construction pits, water inconveniences**
- a) Comprises de-watering of construction pits that exceed 500 litres/minute (pumping, waterproofing, drainage of water etc.), equipment and devices for draining the water to approved outlets beyond the construction pit, and any other inconveniences that the water might entail. If requested by the Project Owner, the contractor shall submit documentation of the quantity of water that is removed.
- x) The costs shall be given as a lump sum. Unit: LS
- 81.2 Scaling above water**
- a) Comprises scaling of specified types above water, including removal of the scaled material.
- Scaling is regarded as carried out above water if the planned level at which the scaling work is to be carried out lies above the water-table, or the construction pit is intended to be a dry construction pit at this level.
- c) The entire foundation contact surface and a minimum distance of 0.2 m beyond this area shall be scaled. The scaling shall be completed immediately before the next work operation is carried out.
- x) Quantity shall be measured as planned scaled area including the area up to 0.2 m beyond the contact area of the foundation. Unit: m²
- 81.21 Levelling and scaling to undisturbed ground in soils, construction sites above water**
- a) Comprises scaling and levelling to undisturbed ground after excavation of construction pits above water.
- c) Scaling shall be carried out without disturbing the soils, so that the foundation can be cast against undisturbed ground with a strength equivalent to that of the naturally consolidated soils. The levelled bottom of the pit shall be even and without depressions and channels formed, for example, by the teeth on the grab bucket
- d) Maximum deviations from planned height for the fully levelled bottom are -100 mm, +100 mm.
- x) Quantity shall be measured as planned levelled and scaled area (see Specification 81.2). Unit: m²
- 81.22 Scaling of exposed rock, construction pits above water**
- a) Comprises complete scaling of rock surface so that a foundation can be constructed on it without blasting.
- c) Scaling shall be carried out by manual digging and by hosing with water and/or air, so that the rock surface is completely exposed and cleaned. Coating on the rock shall be removed by flushing with water.
- x) Quantity shall be measured as planned scaled area. See Specification 81.2. Unit: m²
- 81.23 Rough scaling of blasted rock surface, construction pits above water**
- a) Comprises rough scaling of blasted rock surface.
- c) Scaling shall be carried out mechanically down to solid protruding knobs in the blasted rock surface.
- x) Quantity shall be measured as planned scaled area. Specification 81.2. Unit: m²
- 81.24 Fine scaling of blasted rock surface, construction pits above water**
- a) Comprises fine scaling of blasted rock surface, including rough scaling.
- c) All loose material shall be scaled from the rock by means of air- or water-hosing, for example.
- x) Quantity shall be measured as planned scaled area. See Specification 81.2. Unit: m²

81.25 Wedge scaling of blasted and fine-scaled rock surface, construction pits above water

- a) Comprises wedge scaling of fine scaled rock surface to remove spalled or fractured rock up to a mean depth of 0.3 m.

Wedge scaling shall only be carried out according to agreement with the Project Owner. Fine scaling shall be calculated according to Specification 81.24.

If the mean scaling depth exceeds 0.3 m, the Project Owner shall be notified to allow for an evaluation of the conditions and agreement concerning any further scaling.

- c) The areas for which wedge scaling has been agreed shall be scaled of all loose and spalled rock as far as possible. Coating on the rock shall be removed by hosing with water.
- x) Quantity shall be measured as completed wedge-scaled area with a mean depth of up to 0.3 m. In areas where the mean depth exceeds 0.3 m, the area shall be doubled. Unit: m²

81.3 Excavation below water

- a) Comprises excavation of soil, blasted rock and demolished boulders below water. Excavation work is regarded as carried out below water when the excavation site lies in or under the water-table and is not planned as a dry construction pit.

Comprises rigging for excavation, actual excavation (grabbing, dredging, vacuum-dredging, pumping etc.) with loading or deposition of excavated soils near the excavation site, mechanical scaling of exposed rock surface, levelling of the bottom of the construction pit, and any necessary maintenance of the construction pit.

Rocks with a volume of 1.0 to 10 m³ are regarded as boulders. Boulders larger than 10 m³ are regarded as solid rock.

Excavation of rocks less than 1.0 m³ in size and demolished boulders is included in the specification. Demolition of boulders in soils is included in Specification 82.24.

- c) As in Specification 81.1.
- d) Permitted deviation of the foundation sole is ± 0.2 m for water depths of up to 8 m, and ± 0.3 m for water depths in excess of 8 m unless otherwise indicated in *the special specifications*. For other tolerances and/or applied levelling layers, see *the special specifications*.
- x) The unit price quoted shall apply to work carried out to the specified depth ± 1 m at depths of up to 10 m and specified depth $\pm 10\%$ of the depth at depths of over 10 m. Water depth is measured from the water-table (see Specification 81 a). The unit price applies to excavation of blasted rock even if the depth exceeds the tolerances above when the increase in depth is due to the execution of the blasting work and the contractor himself has carried out the blasting.

Where there is major uncertainty about depth, a separate schedule should be included in the bill of quantities for unit prices depending on depth. Also in the case of major uncertainty regarding quantity and/or layer thickness, a separate schedule should be specified for unit prices depending on variations in quantity and/or layer thickness.

In braced construction pits, volume shall be calculated as planned surface measured internally within bracing / sheet piling multiplied by the height from the planned base of the construction pit or the water-table.

In an unbraced construction pit, volume shall be calculated as indicated below, unless otherwise specified.

For construction pits in soils, volume shall be calculated up to the slope plane that cuts the planned base level 1.0 m from the outside of the wall/sole/foundation. Side slopes shall be calculated with a slope of 1:1 unless otherwise specified (see figure below). If the specified profile proves not to be stable, and the work has been carried out in compliance with guidelines issued, calculation shall be based on necessary completed in-place volume.

For construction pits in rock, quantity shall be measured as planned in-place volume according to blasting profile (cf. Specification 82.1). Calculations shall be based on vertical side surfaces and a distance from the excavation (blasting) line to the braced sole/foundation as given in the table below, if the foundation is not intended to be cast directly against rock.

For construction pits in soil and rock, soil excavation shall be calculated up to 1.0 m beyond the blasting line. Side slopes are not calculated as having a foot that is lower than the foundation depth. (See figure).

Table 81.1-1		
Height (h) of sole/foundation	Excavation beyond sole/foundation (b ₂)	
	Sole/foundation on soil	Sole/foundation on rock
Up to 0.5 m	0.50 m	1.0 m
0.5 – 1.0 m	0.75 m	1.0 m
Over 1.0 m	1.0 m	1.0 m

For columns and walls without a sole/foundation, it is assumed that $h > 1.0$ m and $b_2 = 1.0$ m.

Excavation for any planned levelling layer below the foundation shall be included in the excavated material without making a change in the location of the side slopes.

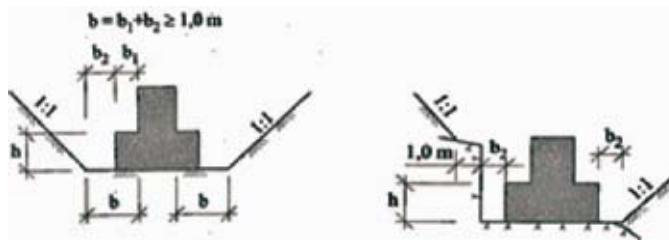

- x) Quantity shall be measured as planned in-place volume. Unit: m^3

81.31 Rigging for excavation work below water

- a) Comprises measures necessary to put excavating equipment into operational condition on the construction site, for example access (which is not included in Principal Specification 1), ground reinforcement / scaffolding, floating rig etc. plus de-rigging and removal of equipment and temporary installations when the work has been completed.

- x) The costs shall be given as a lump sum. Unit: LS

81.311 Rigging for excavations below water, per construction pit

- a) As in Specification 81.31.

- x) Costs shall be given as a lump sum per construction pit. Unit: LS

81.32 Excavation of soils in unbraced or braced construction pit below water

- a) Includes excavation (including grabbing, dredging, vacuum-dredging, pumping etc.) of soils and demolished boulders, with loading or deposition of excavated material near the excavation site, and levelling of the bottom of the construction pit. For excavation in braced construction pits, inconveniences due to bracing, precautionary measures in connection with excavation near bracing, and removal of soil etc. from the bracings shall be included. For a definition of braced construction pit, see Specification 81.13.

- x) Quantity shall be measured as planned in-place volume. See Specification 81.3. Unit: m^3

81.34 Excavation of blasted rock in unbraced or braced construction pits below water

- a) Comprises excavation of blasted rock, including adjustment of contour for construction pit, with loading or deposition of excavated material near excavation site.

- x) Quantity shall be measured as planned in-place volume according to blasting profile. See Specification 81.3. Unit: m^3

81.36 Supplement for loosening of hard material in unbraced or braced construction pits below water

- a) Comprises supplement for loosening of hard material in connection with replacement of equipment or blasting. Hard material is defined as material that has a diggability of less than 30% of a full grab using a grab with a weight of 8 tons. Before the specification is employed, the Project Owner must approve the contractor's documentation of diggability.

- c) The contractor shall carry out separate loosening (for example by blasting while complying with any restrictions that might be specified in *the special specifications*).

- x) Quantity shall be measured as planned in-place volume. See Specifications 81.3 and 81.13. Unit: m^3

81.361 Re-rigging with alternative equipment

- a) Comprises all costs that come in addition to Specification 81.31 for putting alternative excavation equipment, blasting equipment or other equipment in operational condition on the construction site, and de-rigging and removal of this equipment after work has been completed. The specification is applicable if the material is hard (see Specification 81.36 a).

- x) The costs shall be given as a lump sum. Unit: LS

81.362 Loosening of hard material/soils below water

- a) Comprises loosening, for example by blasting, of hard material as a separate work operation before excavation (see Specification 81.36 a).

- c) The loosening method must be chosen on the basis of material type and the intended excavation equipment, while complying with any restrictions that might be specified in *the special specifications*.

- x) Quantity shall be measured as in-place volume of ripped material, measured in the construction pit. Unit: m^3

- 81.37 Supplement for excavating in unbraced or braced construction pits with piles below water**
- a) Comprises extra costs associated with excavation in construction pits with piles below water.
 - x) Quantity shall be measured as planned in-place volume. See Specification 81.3 and 81.13. Unit: m³
- 81.4 Scaling below water**
- a) Comprises scaling of specified types below water, including removal of the scaled material. Scaling is regarded as carried out below water if the planned level at which the scaling work is to be carried out lies in or below the water-table and the construction pit is not planned as a dry pit to this level.
 - c) The entire foundation contact area and a minimum distance of 0.4 m beyond this area shall be scaled. The scaling shall be completed immediately before the next work operation is carried out.
 - x) Quantity shall be measured as planned scaled area including the area up to 0.4 m beyond the foundation contact surface. The unit price quoted shall apply to work carried out to the specified depth \pm 1 m at depths of up to 10 m, specified depth \pm 10% of the depth at depths of over 10 m. Water depth shall be measured from the water-table to the deepest planned bottom level of the construction pit. The unit price applies even if the depth exceeds the tolerances above when the increase in depth is due to execution of excavation or blasting work, and the contractor himself has carried out this work. Where there is major uncertainty about depth, a separate table should be included in the bill of quantities for unit prices depending on depth. Unit: m²
- 81.41 Levelling and scaling to undisturbed ground in soils, construction pits below water**
- a-d) As in Specification 81.21.
 - x) As in Specification 81.4. Unit: m²
- 81.42 Scaling to exposed rock, construction pits below water**
- a-c) As in Specification 81.22.
 - x) As in Specification 81.4. Unit: m²
- 81.43 Rough scaling of blasted rock surface, construction pits below water**
- a-c) As in Specification 81.23.
 - x) As in Specification 81.4. Unit: m²
- 81.44 Fine scaling of blasted rock surface, construction pits below water**
- a-c) As in Specification 81.24.
 - x) As in Specification 81.4. Unit: m²
- 81.45 Wedge scaling of blasted and fine-scaled rock surface, construction pits below water**
- a-c) As in Specification 81.25.
 - x) As in Specification 81.4. Unit: m²
- 81.5 Transport of soil**
- a) Comprises transport, tipping and levelling of soils, blasted rock and demolished boulders, including any tipping/delivery charges or similar. Loading is included in the excavation specifications.
 - x) Quantity shall be measured as planned in-place volume measured in the construction pit. Unit: m³
- 81.51 Transport on land**
- a) Comprises transport on land.
 - x) Quantity shall be measured as planned in-place volume measured in the construction pit. Unit: m³
- 81.511 Transport on land within the construction site**
- a) Comprises transport within the site and tipping. Information regarding the proposed use and any intermediate storage of soils on the site shall be submitted to the Project Owner on request.
 - x) Quantity shall be measured as planned in-place volume measured in the construction pit. Unit: m³
- 81.512 Transport on land to assigned dump/depot**
- a) Comprises transport to the dump/depot assigned by the Project Owner and tipping.
 - c) The location and any restrictions regarding filling dump/depot will be set out in *the special specifications*.
 - x) Quantity shall be measured as planned in-place volume measured in the construction pit. Unit: m³
- 81.513 Transport to dumps procured by the contractor**
- a) Comprises transport of materials specified in *the special specifications* to dumps provided by the contractor, and tipping.

- x) Quantity shall be measured as planned in-place volume measured in the construction pit. Unit: m³
- 81 .514 Transport on land in accordance with table of transport distances**
- a) Comprises transport of materials and tipping.
 - x) Quantity shall be measured as planned in-place volume measured in the construction pit. Unit: m³
- Unit prices for alternative transport distances shall be quoted in connection with subdivision of the specification using 6-digit codes.
- 81.52 Levelling of dump/depot**
- a) Comprises levelling of the excavated material at the dump/depot.
 - c) Reference is made to *the special specifications* regarding any restrictions on dump heights/layer thicknesses etc.
 - x) Quantity shall be measured as planned in-place volume measured in the construction pit. Unit: m³
- 81.53 Transport by water**
- a) Comprises transport by water to dump, and dumping.
 - x) Quantity shall be measured as planned in-place volume measured in the construction pit. Unit: m³
- 81 .531 Transport by water to assigned dump**
- a) Comprises transport on water and dumping at assigned dump.
 - x) Quantity shall be measured as planned in-place volume measured in the construction pit. Unit: m³
- 81 .532 Transport by water to alternative dumps**
- a) Comprises transport by water to alternative dumps and dumping of material.
 - x) Quantity shall be measured as planned in-place volume measured in the construction pit. Unit: m³
- Unit prices for alternative transport distances shall be stated in connection with subdivision of the specification using 6-digit codes.
- 81.54 Transfer of soils and blasted rock**
- a) Comprises transfer from boat (barge) to land-based vehicle, or vice versa.
 - x) Quantity shall be measured as planned in-place volume measured in the construction pit. Unit: m³
- 81.6 Placement of material above water**
- a) Comprises delivery and placement of material above water, for example filter layers, sub-base and base layers/levelling layers under foundations, fill under foundations and transition slabs, backfilling against foundations, retaining walls and abutments, erosion protection etc. according to *the special specifications*.
- The work is regarded as carried out above water if the fill volume is above the water-table or on a drained construction site (see Specification 81).
- b) For requirements regarding materials and possible alternative quarries, borrow pits or suppliers, see *the special specifications*.
 - c) For fills and backfills against structures, materials and work shall, unless otherwise specified in *the special specifications*, be in accordance with Handbook 018 Vegbygging (Road Construction – Norwegian text). Filling and compaction work shall be executed with care so that structural components are not loaded unnecessarily and damage does not occur.
 - d) For permanent slopes, the permitted deviation from the planned profile is ± 0.15 m if they are otherwise without irregularities (depressions or knobs).
 - x) Quantity shall be measured as planned placed volume. Unit: m³
- 81.61 Placement of local materials**
- a) Comprises loading and transport from road cut or assigned borrow pit and placement, compacting and levelling of local materials. Specification 81.63 shall be used for material in contact with structures.
 - x) Quantity shall be measured as planned placed volume. Unit: m³
- 81 .611 Placement of local sand and gravel**
- 81 .612 Placement of local rock material**
- 81 .613 Placement of local mixed materials**

81.62 Delivery and placement of materials

- a) Comprises procurement, loading, transport to site and if relevant temporary storage and placement layer by layer, compaction and levelling of material. Filter layers are included in Specification 52.1. For material placed against structures, Specification 81.63 is used.
- x) Quantity shall be measured as planned placed volume. Unit: m³

81 .621 Delivery and placement of sand and gravel

81 .622 Delivery and placement of sorted crushed rock and gravel

81 .623 Delivery and placement of blasted rock

81 .624 Delivery and placement of light-weight material

b-c) See *the special specifications* and Specification 24.7.

- x) Quantity shall be measured as planned placed volume. Unit: m³

81.63 Material placed against structures

- a) Comprises delivery, placement and compaction of material against structures.

Specification 81.61 or 81.62 are used for any fill under structures. Special compaction of the ground before filling is included in Specification 24.1, any filter layers are included in Specification 52.1, any geotextile is included in Specification 52.2 and frost insulation in Specification 52.3.

- b) If requirements relating to the material are not specified in *the special specifications* or in Handbook 018 Road Construction, well graded sand, gravel or stone may be used. Stones with a mean particle size of over 300 mm must not be used closer than 1 m from the structure. Material with $d_{max} < 120$ mm shall be used in contact with waterproofing and any frost protection, at the same distance from the structure, taking care not to puncture the insulation.

The part of the fill that may be exposed to frost must be constructed of materials that are non frost-susceptible. Soils with humus content higher than 3% shall not be used.

The material must have a particle size distribution that makes the fill self-draining, i.e. maximum 8% passing through a 0.063 mm sieve for material < 20 mm.

Geotextile shall be used to separate materials that do not satisfy the filter criteria from local soils (Specification 52.2). When a separating geotextile, is used, the fabric type and execution of work shall be selected in accordance with *the special specifications*. Alternatively, geotextile may be replaced by a filter layer (separate Specification) that satisfies the filter criteria of both the local soils and the fill.

- c) Where an embankment forms the foundation for a road or other structure, special emphasis shall be placed on good compaction, so that future settlements are minimised/avoided. Compaction of materials shall take place in such a way that the structure and any waterproofing, frost insulation etc. is not damaged.

Recommended layer thickness, minimum requirements regarding compaction and maximum weight of compaction equipment are specified in Handbook 018 Road Construction.

In order to meet compaction requirements for sand and gravel, placement must normally be performed with a water content near the optimal level.

For road embankments, a formation level and if relevant support for an transition slab shall be established on top of the embankment. The embankment slopes shall be levelled with an inclination as shown in the plans.

- d) The tolerance for the embankment slope is ± 150 mm, and for the formation surface ± 40 mm.
- x) Quantity shall be measured as planned placed volume. Unit: m³

81.631 Levelling layers

- a) Comprises delivery, placement, compaction and levelling of levelling layer under transition slabs and other structures. Any beams of wood, steel or concrete for support of prefabricated concrete culverts, for example, are not included in the specification.

- b) The levelling materials must have a particle size distribution that makes them suitable for exact levelling, and satisfy the filter criteria in relation to adjacent material. The material shall be self-draining and, in areas where frost may occur, non frost-susceptible.

For element culverts and corrugated steel pipes, the uppermost 0.3 m under the structures shall be sand or gravel, unless otherwise specified.

- c) Compaction shall be carried out in such a way that the stability and strength of adjacent soils is not disturbed. Normally a levelling layer with a thickness of up to 0.2 m shall be compacted with at least 5 passes of a vibroplate with a total weight of up to 150 kg. Compaction of greater thicknesses shall be carried out as described in Specification 81.63 c).

Levelling layers under prefabricated structural components (culvert elements, retaining wall elements, steel and concrete pipes etc.) shall be levelled precisely in accordance with the shape of the structural

component. For culverts, particular account shall be taken of the roof slope of the culvert, and the superelevation, if relevant.

The levelling layer shall extend at least 0.2 m beyond the contact surface of the foundation/structural component.

- d) Tolerances for levelling layers are:
 - Combined building tolerance: +20 mm, -50 mm
 - Surface deviation: 20 mm measured with 1-m straight-edge
- x) Quantity shall be measured as planned levelling layer area, including the area up to 0.2 m beyond the contact surface of the foundation/structural component. Unless otherwise specified, the levelling layer shall be assumed to have a mean thickness of 150 mm. Unit: m²

81 .632 Fill with levelling

- a) Comprises delivery, placement and compaction of fill under foundations and other structures, and levelling of the fill layer at a given level. Any delivery of special materials (crushed stone, gravel etc.) for levelling is included.

Any filter layers are included in Specification 52.1, any geotextile is included in Specification 52.2. Any beams of wood, steel or concrete for support of prefabricated concrete culverts, for example, are not included in the specification.

- b-c) For element culverts and corrugated steel pipes, the uppermost 0.3 m of backfill shall be sand or gravel.

Levelling shall be carried out with materials and as described for Specification 81.631.

- d) As in Specification 81.631.
- x) Quantity shall be measured as planned placed volume. Unit: m³

81 .633 Filling against structures

- b-c) Fill material (sand, gravel, blasted rock) may be selected according to Handbook 018 Road Construction.

- x) Quantity shall be measured as planned placed volume. Unit: m³

81.6331 Sand or gravel against structures

81.6332 Crushed material against structures

81.6333 Light-weight material against structures

- b-c) See *the special specifications* and Specification 24.7.

- x) Quantity shall be measured as planned placed volume. Unit: m³

81 .634 Backfilling against foundations

- a) Comprises backfilling, compaction and levelling of local materials against and around foundations.

- b) If surplus materials are available, the most suitable material shall be used for backfilling.

- x) Quantity shall be measured as planned placed volume. Unit: m³

81.7 Placement of material below water

- a) Comprises delivery and placement of material below water in connection with bridges and quays, for example sub-base layer / levelling layer below foundations, stone fills under foundations and transition slabs, filling/backfilling against foundations and abutments, placement of pitching and reversed filters (erosion protection), placement of jetties, breakwaters etc.

The work shall be regarded as carried out below water if the fill volume is in or below the water-table and the work site is not planned as a dry construction pit. The filling work must be directed and monitored by divers or similar in order to achieve accurate placement, slope angles, levelling and height control.

- b) For requirements regarding materials and possible alternative quarries, borrow pits or suppliers, see *the special specifications*.

- x) Quantity shall be measured as planned placed volume. Unit: m³

81.71 Rigging for placement of material below water

- a) Comprises special rigging that is necessary for placement of material, such as establishment of transport systems, rigging for accurate placement, height control and levelling below water.

- x) The costs shall be given as a lump sum. Unit: LS

81.72 Placement/filling of local materials below water

- a) Comprises placement/filling and levelling of local materials below water. Loading and transportation of material from road cut or from an assigned borrow pit are included in the specification.

- x) Quantity shall be measured as planned placed volume. Unit: m³
- 81 .721 Placement/filling of local sand and gravel below water**
- 81 .723 Placement/filling of local mixed material below water**
- 81.73 Delivery and placement of material below water**
 - a) Comprises delivery, placement/filling and levelling of material below water.
 - x) Quantity shall be measured as planned placed volume. Unit: m³
- 81 .731 Delivery and placement of sand and gravel below water**
- 81 .732 Delivery and placement of sorted crushed stone and gravel below water**
- 81 .733 Delivery and placement of blasted rock below water**
- 81.74 Material against structures below water**
 - a) Comprises delivery, placement and compaction of material against structures. Specifications 81.72 or 81.73 are used for fill under structures.
 - b-c) See Specification 81.63.
 - x) Quantity shall be measured as planned placed volume. Unit: m³
- 81 .741 Levelling layer below water**
 - a) Comprises delivery, placement, compaction and levelling of levelling layer under foundations and other structures below water. Any beams of steel or concrete for placement of prefabricated concrete culverts, for example, are not included in the specification.
 - b) The levelling material shall have a particle size distribution that makes it suitable for exact levelling. For element culverts and corrugated steel pipes, the uppermost 0.3 m under the structures shall be sand or gravel, unless otherwise specified in *the special specifications*.
 - c) Compaction shall take place in such a way that the stability and strength of adjacent soils is not disturbed. Levelling layers under prefabricated structural components (culvert elements, retaining wall elements, steel and concrete pipes etc.) shall be levelled precisely in accordance with the shape of the structural component. For culverts, particular account shall be taken of the roof slope of the culvert, and the superelevation, if relevant. The levelling layer shall extend at least 0.4 m beyond the contact surface of the foundation/structural component.

Tolerances for levelling layer are:
- Combined building tolerance: +30 mm, -80 mm
- Surface deviation: 30 mm measured with 1 m straight-edge
 - x) Quantity shall be measured as planned levelling layer area, including the area up to 0.4 m beyond the contact surface of the foundation/structural component. Unless otherwise specified in *the special specifications* or in the plans, the levelling layer shall be assumed to have a minimum mean thickness of 0.15 m. Unit: m²
- 81 .742 Fill with levelling below water**
 - a) Comprises delivery, placement and compaction of fill under foundations and other structures below water, and levelling of the sub-base layer at a specified level. Any delivery of special materials (crushed stone, gravel etc.) for levelling shall be included. Any beams of steel or concrete for placement of prefabricated concrete culverts, for example, shall not be included in the Specification.
 - b-c) For element culverts and corrugated steel pipes, the uppermost 0.3 m of backfill shall be sand or gravel. Levelling shall be carried out with materials and as described for Specification 81.741.
 - d) As in Specification 81 741.
 - x) Quantity shall be measured as planned placed volume. Unit: m³
- 81 .743 Filling against abutment below water**
 - a-c) Fill material (sand, gravel, blasted rock) can be chosen according to Handbook 018 Road Construction.
 - x) Quantity shall be measured as planned placed volume. Unit: m³
- 81 .744 Backfilling against foundations below water**
 - a) Comprises backfilling, compaction and levelling of local materials against and around foundations under water.
 - b) If surplus materials are available, the most suitable material shall be used for backfilling.
 - x) Quantity shall be measured as planned placed volume. Unit: m.

- 82 ROCK**
- a) Comprises work in rock, such as blasting, demolition of blocks, isolation of aggressive rock, drilling in rock (and concrete) etc.
 - c) It is the contractor's duty and responsibility to ensure the necessary measures are carried out so that the surroundings, including permanent or temporary installations, buildings, structures etc., are not damaged by vibrations, air shock waves, flying debris or similar.
- 82.1 Blasting/demolition above water**
- a) Comprises work that is necessary in connection with loosening/blasting of rock or demolition of blocks in the construction pit for foundations, anchoring etc., where the work is expected to be carried out above the water-table or in a dry construction pit, cf. Specification 81 a). Includes rigging, any supplementary scaling to enable drilling and charging, drilling including necessary underdrilling, charging, proper cover, blasting, proper operational scaling and securing of the works, any water drainage/drawbacks due to water, demolition of blocks, clearing of rubble after blasting/demolition etc.
- Removal of soils from the rock head (machine scaling) loading/excavation of blast rubble and cleaning of the bottom of the construction pit are included in Specification 81.
- x) Quantity shall be measured as the planned in-place volume according to the blasting profile. Exposed rock shall be profiled before blasting commences. Rock heights less than 1.0 m are considered to be 1.0 m. No supplement is given for overbreak or afterblasting. Unless otherwise stated, the volume shall be measured as indicated in Specification 81.1. Unit: m³
- 82.11 Rigging for blasting above water**
- a) Comprises measures that are necessary to perform the blasting and which are not included in Specification 82.12.
 - x) The cost shall be given as a lump sum. Unit: LS
- 82.12 Blasting above water**
- a) Comprises all work concerning the actual blasting operations, such as supplementary scaling to be able to drill and charge, drilling including necessary underdrilling, charging, proper cover, blasting, proper operational scaling and reinforcement of the works, any water drainage/drawbacks due to water, clearing of rock fall after blasting etc.
 - x) As in Specification 82.1. Unit: m³
- 82.14 Demolition of boulders above water**
- a) Comprises demolition of boulders in soil by blasting, use of percussion drill or similar, including necessary rigging/de-rigging. Comprises boulders minimum 1.0 m³ and maximum 10.0 m³ in size (boulders larger than 10.0 m³ are considered to be solid rock). The volume of the boulders is included in the planned in-place volume for excavation, loading and transport.
 - x) Quantity shall be measured as number of blocks. Unit: pcs
- 82.141 Demolition of boulders from 1.0 m³ up to and including 5.0 m³**
- 82.142 Demolition of boulders from 5.0 m³ up to and including 10 m³**
- 82.15 Rigging for further blasting above water**
- a) Comprises rigging for further blasting in cases where the rock quality at the completed blasting level cannot be approved.
 - x) The cost shall be given as a lump sum. Unit: LS
- 82.2 Blasting/demolition below water**
- a) As in Specification 82.1. Blasting is considered to be carried out below water when the blast volume lies in or below the water table and the worksite will not be drained, cf. Specification 81 a). Any special restrictions, for example due to fish and other environmental requirements, shall be given in *the special specifications*.
 - x) Quantity shall be measured as planned in-place volume according to the blast profile. Stripped rock shall be profiled before blasting. Rock heights of less than 1.0 m are considered to be 1.0 m. No supplement is given for overbreak or trim blasting. The stated unit price shall apply for work performed to the given depth ±1 m for depths down to 10 m, the given depth ±10% of the depth for depths of over 10 m. In the case of major uncertainty about depths, the bill of quantities shall be provided with a separate schedule of unit prices according to depth. For calculation of the planned in-place volume, see Specification 81.3. Unit: m³
- 82.21 Rigging for blasting/demolition below water**
- a) As in Specification 82.11. Also includes floating rigs etc.
 - x) The cost shall be given as a lump sum. Unit: LS

- 82.22 Blasting below water**
- a) As in Specification 82.12, below water.
 - x) As in Specification 82.2. Unit: m³
- 82.24 Demolition of boulders below water**
- a) As in Specification 82.14, below water. Any floating rigging is included in Specification 82.21.
 - x) Quantity shall be measured as number of boulders. Unit: pcs
- 82.241 Demolition of boulders from 1.0 m³ up to and including 5.0 m³**
- 82.242 Demolition of boulders from 5.0 m³ up to and including 10 m³**
- 82.25 Rigging for further blasting below water**
- a) Comprises re-rigging for further blasting in the case where rock quality at the completed blasting level cannot be approved.
 - x) The cost shall be given as a lump sum. Unit: LS
- 82.3 Isolation of aggressive rock**
- a) Comprises isolation of rock that may be the source of attacks on concrete (alum shale etc.) or other construction materials.
 - x) See *the special specifications*. Unit: m²
- 82.4 Drilling holes and core drilling**
- a) Comprises drilling holes and core drilling, including rigging, set-up and de-rigging, drilling holes with or without the extraction of cores in solid rock or cured concrete, and finishing work for the holes drilled. Drilling holes for bolts and tension anchors is included in Specification 83.7.
 - c-e) With respect to drillhole diameter, length, inclination, location and tolerances as well as rock or concrete quality, see *the special specifications*.
 - x) Quantity shall be measured as completed length of drillhole. Unit: m
- 82.41 Drilling holes in rock and concrete**
- a) Comprises rigging, de-rigging and drilling of holes in rock or concrete, including removal of drilled material. The specification also includes any drilling of pilot holes.
 - c-e) Holes shall be drilled with a diameter, length, inclination and tolerances as specified.
 - x) Quantity shall be measured as completed length of drillhole. Unit: m
- 82.411 Rigging and set-up for drilling holes**
- 82.4111 Rigging for drilling holes**
- a) Comprises putting drilling equipment in operational condition on site. As such it includes transport of the equipment to the construction site, building access facilities not included in Principal Specification 1, scaffolding, if relevant, rigging and de-rigging of drilling equipment.
 - x) The cost shall be given as a lump sum. Unit: LS
- 82.4112 Set-up for drilling holes**
- a) Comprises set-up, moving and precise positioning of drilling machinery and equipment, and all costs related to the basis for measurement and exact starting point for drilling.
 - x) Quantity shall be measured as number of drillholes. Unit: pcs
- 82.412 Drilling of holes**
- a) Comprises drilling holes in rock or concrete, drilling of any pilot holes and reaming of these, as well as removal of drilled material.
 - c-e) Holes shall be drilled according to the diameter, length, inclination and tolerances specified in *the special specifications*.
 - x) Quantity shall be measured as length of drillhole. Unit: m
- 82.413 Casings in drillholes**
- a) Comprises delivery and assembly of casings with packings etc., as well as grouting between casing and rock. For steel core piles, see Specification 83.5.
 - b) The casing shall be of the type and dimensions specified in *the special specifications*. Grouting material shall consist of Portland cement, water and any additives.
 - x) Quantity shall be measured as length of casing of each type and dimensions. Unit: m

- 82.414 Measuring water loss**
- a) Comprises measurement of water loss in boreholes or core boreholes, including rigging and necessary equipment.
For steel core piles, see Specification 83.5.
 - x) Quantity shall be measured as number of measured boreholes. Unit: pcs
- 82.42 Core drilling in rock and concrete**
- a) Comprises drilling w/removal, packing, storage and if relevant dispatch of rock and concrete cores, as well as any refilling of drillholes. Also includes delivery of the necessary number of core cases.
 - c) Drilling shall disturb the core as little as possible. A logbook shall be kept of the drilling and cores shall be marked in accordance with the notes in the logbook so that identification is unambiguous. See Specification 31.2 and *the special specifications*. Boreholes shall normally be refilled with expanding cement grout.
 - x) Quantity shall be measured as completed length of borehole from which core has been extracted.
Unit: m
- 82.421 Rigging for core drilling**
- a) Comprises putting the core drilling machine and equipment in operational condition on the construction site. Thus it includes transport of the equipment to the construction site, building access facilities not included in Principal Specification 1, scaffolding if relevant, rigging and de-rigging of core drilling equipment.
 - x) The cost shall be given as a lump sum. Unit: LS
- 82.422 Set up for core drilling**
- a) As in Specification 82.4112.
 - x) Quantity shall be measured as number of boreholes. Unit: pcs
- 82.423 Drilling and extraction of cores**
- a) Comprises drilling and extraction of cores, post-drilling work on cores and refilling of boreholes if this is specified by *the special specifications*.
 - c) With respect to core diameter and length, see *the special specifications*.
 - x) Quantity shall be measured as completed length of borehole. Unit: m

SUBSURFACE STRUCTURES (PILES, SHEET PILES ETC.)

- a) Includes delivery of materials and works related to subsurface structures, i.e. piles, sheet piles, struts, anchors/bolts, slurry trench walls etc.

Regarding ground improvement see the Main Specification 2 and for securing rock formations, Main Specifications 2 and 3.

Any pre excavations are included in specification 81 and removal of building waste in the ground is included in specification 15. Positioning of piles on site and surveying of actual pile positions are included in specification 13 unless otherwise stated.

See geotechnical reports regarding ground conditions.

- b) Works related to subsurface structures shall be directed by a person with sufficient technical knowledge and practical experience related to the works in question. A foreman with corresponding experience shall monitor the works continuously on site and see to that quality assurance and documentation are carried out. Documentation related to the qualifications of the above mentioned key personnel shall be submitted to the Project Owner before construction activities commence.

In general works related to subsurface structures (piles, sheet piles, etc. with splices, pile shoes and similar) shall be carried out according to existing Norwegian standards and the Code of Practice for Piles 2005 (Pelevledningen 2005) prepared by the Norwegian Geotechnical Society. Any disagreements shall be clarified in consultations between the Project Owner and the contractor.

Steel parts incorporated in subsurface structures shall have steel grade, delivery standard and material certificate according to Table 83-1 unless otherwise stated in the existing NS-EN standards or specified in *the special specifications*.

Element type	Supporting element			Non-supporting element		
	Grade	Delivery standard	Material certificate	Grade	Delivery standard	Material certificate
Steel pipe piles, spirally welded pile pipes Ø: 406 - 1220 mm	[S355NH] see foot note 1)	NS-EN 10210	NS-EN 10204 type 3.1	S355J2H	NS-EN 10219	NS-EN 10204 type 2.2
Pile shoes for steel pipe piles	S355J2	NS-EN 10025-2	NS-EN 10204 type 3.1	S355J2 see foot note 2)	NS-EN 10025-2	NS-EN 10204 type 2.2
Time Steel piles Massive steel profiles	S355N	NS-EN 10025-3	NS-EN 10204 type 3.1			
Pile shoes for steel piles	See special specifications					
Steel core piles, non-welding spliced Ø: 70 - 200 mm	S355J2AR	NS-EN 10025-2	NS-EN 10204 type 3.1			
Steel core piles, welding spliced Ø: 70 - 200 mm	S355	NS-EN 10025-3	NS-EN 10204 type 3.1			
Casings (steel core piles) Ø: 70 - 200 mm	[S355J2H] see foot note 1)	NS-EN 10210	NS-EN 10204 type 3.1	S355J2H	NS-EN 100219	NS-EN 10204 type 2.2
Sheet pile steel	S355GP	NS-EN 10248	NS-EN 10204 type 3.1			
Dowels/foot bolts (all pile/sheet pile types)	S355J2	NS-EN 10025-2	NS-EN 10204 type 3.1			

1) Pile pipes for steel pipe piles and casings for steel core piles are normally not supporting elements.

This grade is utilised if specified in *the special specifications*.

2) This group of pile shoes may be used as pile tips in soils.

- c) For geotechnical conditions, restrictions and specifications, see *the special specifications*. . If substantial deviations from the specified/assumed conditions occur, the Project Owner shall be notified immediately.

Before construction activities on subsurface structures commence, the contractor shall investigate whether buried cables, service pipes or culverts etc. are present on the site in question. All obstacles (building waste, rafts, blocks etc) shall be removed in advance by excavation if this is considered a safe and convenient way to carry out the construction work. Suitable materials shall be used for backfilling purposes.

- e) A quality control plan shall be presented to the Project Owner before construction activities commence.

The quality control plan shall be produced in accordance with geotechnical project class (NS 3480 or more recent versions) as specified in *the special specifications*.

Welding inspection for piles shall be performed in accordance with specification 85. Inspection classes are defined in Table 83.2.

	Supporting element		Non-supporting element	
	End bearing pile	Friction pile	End bearing pile	Friction pile
Length Welded splice pile elements	3	3	2	2
Pile shoe but weld	3	1	-	-
Pile shoe fillet weld	3	1	-	-

Concrete works shall be carried out and inspected in accordance with NS 3465, inspection class "Extended inspection".

If the needs for testing and inspection are increased as a result of circumstances the contractor is clearly responsible for, the increased testing and inspection costs shall be covered by the contractor.

83.1 Concrete piles

- a) Comprises deliveries and pile works including complete pile driving and stop acceptance criteria, dowel installations if applicable and accepted concrete piles, as well as any additional site investigations the contractor finds necessary in order to select pile lengths and accept the measuring rules in point x). In addition noise reducing measures during pile driving shall be included if this is specified in *the special specifications*.

83.11 Preparatory and general works

83.111 Recording of pile and pile driving logs

- a-e) Complete pile and pile driving logs shall be recorded for all pile works with concrete piles. The pile driving logs shall be recorded on the Public Roads Administration's form 473 or equivalent. An example on how the form shall be filled in is shown on page 241 in the Code of Practice for Piles 2005 (Peleveiledningen 2005).

Unless otherwise stated the pile driving logs shall be maintained continuously and submitted to the Project Owner on a daily basis, at the latest one day after the driving was performed. The logs shall be available for inspection at any time before they are submitted.

Complete (final) pile and pile driving logs for all piles in a pile group shall be submitted to the Project Owner before the piles are cut. See also specification 83.17.

The Project Owner shall be given reasonable time to evaluate and if necessary make check calculations on the pile group on the basis of the pile logs.

In addition the pile logs shall be duplicated and distributed as specified in *the special specifications* or as agreed with the Project Owner.

The pile driving logs shall at least contain the following:

- name of person in charge of the pile works
- name of foreman and the person responsible for recording logs
- identification of each pile
- pile type, cross-sectional area and material qualities
- accumulated length and length of each pile element
- type and length of pile shoe
- type of pile driving equipment – height of hammer drop, supplied energy and/or stroke frequency
- number of blows per metre and penetration per blow series
- movement monitoring
- deviations from specifications
- conditions that may influence the bearing capacity

The final pile and pile driving logs shall also contain:

- all levelling measurements with dates, see specification 83.14 and subspecifications.
- measured final position/inclination and direction as well as curvature if any
- special control measurements as specified in *the special specifications*
- calculated pile shoe level
- length of pile to be paid for

- x) The costs shall be given as a lump sum. Unit: LS

83.112 Supplementary site investigations for concrete piles

- a) Includes all work with supplementary site investigations.
- b) The extent of the site investigations is determined by what the contractor considers necessary in order to determine pile lengths.

For assumed complicated site conditions supplementary site investigations may be performed in order to clarify project feasibility. The need for such investigations shall be decided in consultation with the Project Owner.

Choice of drilling method and performance shall be in accordance with Handbook 15 Feltundersøkelser (Field investigations).

Quantity shall be measured as number of borehole metres. Unit: m

83.113 Noise reducing measures

- a) Comprises noise reducing measures as specified in *the special specifications*
- x) Costs shall be given as a lump sum. Unit: L5

83.114 Spudding

- a) Comprises prepiling by use of a spud as specified in *the special specifications*
- x) Quantity shall be measured as number of metres of planned spudding. Unit: m

83.115 Removal of clay cores

- a) Comprises removal of clay cores in order to reduce the extent of soil displacement/soil remoulding or other unwanted effects of pile driving. Also covers all actions necessary in order to penetrate firm layers/drying crust including actions to avoid plugging.

Unless otherwise stated in *the special specifications*, removal of clay cores shall be carried out to the specified depth and with the cross-sectional area necessary in order to achieve the intended effect. This shall be decided in consultation with the Project Owner.

Equipment making it possible to supply water or air to the bottom of the clay core during coring operations shall be used. The pile shall be driven immediately after the clay core has been removed. Only one hole shall remain open at any time.

- x) Quantity shall be measured as successfully performed length of clay coring measured from the ground level to the bottom of cored holes. Unit: m

83.12 Delivery of concrete piles and accessories

- a) Comprises all deliveries of piles and accessories.
- b) The piles shall be produced at factories certified by an accredited technical control institute, and shall be delivered with certificates with production specifications and the results of quality control tests.

Type of pile, dimensions, load capacity etc. shall in general correspond to pile type P270 or P345 according to NS 3046 or more recent Norwegian standards replacing this standard. See *the special specifications*.

Factory produced concrete pile elements shall be in accordance with NS-EN 12794, pile type class 1 according to NS-EN 12794 Table 3, angle deviation class AD1 according to NS-EN 12794 Table 1, and/or more recent Norwegian standard(s).

The concrete shall be of strength class B45, durability class MF40 and chloride class Cl 0.10 according to NS-EN 206-1. The coarse aggregate in the concrete mix shall consist of crushed stone with D_{max} in the range 16 – 20 mm. The concrete E-module shall be documented and shall be stated on demand.

The reinforcement shall be of grade B500NC according to NS 3576-3. The concrete cover for the outer reinforcing layer (stirrups) shall be 45 ± 10 mm, for the free (not cast against formwork) surface $45 +20/-10$ mm. The reinforcement shall be fixed together with metal wires without the use of welds and without mounting bars protruding outside the structural part of the reinforcement. The reinforcement shall be bound tightly together so that no bars may shift when the concrete is poured. Reinforcement spacers shall be applied on 3 sides (against the formwork) at c/c max. 1.0 m. Spacers shall be made of mortar or concrete of grade B45, MF40 or MF40, Cl 0.10 according to NS-EN 206-1.

The percentage of steel reinforcement shall be large enough and spaced in such a way that the piles will not be damaged due to handling and pile driving, minimum reinforcement shall be 2%.

The concrete in pile elements shall be protected against dehydration until at least 60% of the required characteristic strength has been achieved. Pile elements shall satisfy strength class B35 and have cured for minimum 7 days before transportation from the factory to the construction site, and have cured for at least 14 days before being driven. All pile elements shall be marked with date of casting. The piles shall be transported, handled and stored in such a way that the quality of the finished product is not reduced. In addition the elements shall be stored or marked in such a way that there will be no confusion or mixing of different types, ages and grades.

The pile head shall be protected by a steel collar in order to prevent crushing of the concrete during pile driving. The collar shall be made of flat steel mounted before the pile is cast and in a position flush with the pile side surface. All longitudinal reinforcement shall be terminated at the same distance from the pile end surface.

End bearing concrete piles on rock shall be fitted with rock shoes. The longitudinal axis of pile and shoe shall be aligned along the same axis. The length and form of the pile shoe shall be adjusted to the bedrock slope. See *the special specifications*. The hardness of the pile shoe shall be as described in the Code of Practice for Piles 2005 (Peleveiledningen 2005).

Pile elements that prior to driving show open transverse cracks wider than 0.3 mm and with a length greater than half the pile circumference or longitudinal cracks shall not be used. The pile elements shall be without spalling damage that will reduce the reinforcement cover more than the tolerance requirements for cover.

- d) Deviations from the secant line (curvature) shall not be greater than 0.2% measured with a 5 m straightedge. This corresponds to a radius of curvature of minimum 300 m. For piles with a length of less than 5 m the maximum permissible deviation from the secant line is 10 mm. For rectangular or other polygonal piles measurements shall be made on two surfaces at right angle to one other. On each surface the curvature shall be measured along the central line between two arbitrarily selected points. For circular piles measurements shall be taken along two surface lines in planes at right angles to one other and intersecting along the pile axis.

The end surface at the pile top shall be plane and at right angles to the longitudinal axis of the pile and a maximum misalignment of 1:100. End surfaces for spliced piles shall have a maximum misalignment of 1:150.

The pile cross-sectional area shall not deviate more than $\pm 5\%$ from the nominal area.

- x) Quantity shall be measured as completed length of driven piles, measured from the pile shoe to the design cut-off level, including any length of exposed reinforcing bars. Cut-off lengths and splices shall be included in the unit price. Unit: m

83.121 Delivery of concrete piles including pile shoes

- a) Comprises procurement (or production), transportation and storage of massive concrete piles (i.e. without drilling duct).

83.1211 Delivery of pile elements

- a) Comprises delivery of pile elements including splice and/or steel collar.
- x) Quantity shall be measured as specified in specification 83.12, not including pile shoes.

83.1212 Delivery of rock shoes

- a) Comprises delivery of pile-mounted rock shoes.
- b) The rock shoe shall be in accordance with requirements specified in the Code of Practice for Piles 2005 (Peleveiledningen 2005), and shall as a minimum also comply with the requirements of NS 3046 or a more recent Norwegian standard replacing this standard.
- x) Quantity shall be measured as number of shoes. Unit: pcs

83.1213 Delivery of rock shoes with extended core

- a) Comprises rock shoe with extended core mounted on pile.
- b) As in specification 83.1212. The extended core shall be 40 ± 5 mm longer in relation to a normal core.
- x) Quantity shall be measured as number of shoes. Unit: pcs

83.1214 Delivery of soil shoes

- a) Comprises delivery of pile-mounted shoes suitable for driving in soils
- b) The soil shoes shall be in accordance with the Code of Practice for Piles 2005 (Peleveiledningen 2005), and shall as a minimum meet the requirements of NS 3046 or more recent Norwegian standard replacing this standard.
- x) Quantity shall be measured as number of soil shoes. Unit: pcs

83.122 Delivery of concrete piles with drilling duct, including pile shoe

83.1221 Delivery of pile elements with drilling duct

- a) Comprises delivery of pile elements with drilling duct, including splices and/or steel collar.
- b) The drilling duct shall have an internal diameter of minimum 60 mm, or as specified in *the special specifications*.
- x) Quantity shall be measured as in specification 83.12, without pile shoe.

83.1222 Delivery of hollow rock shoe

- a) Comprises delivery of hollow rock shoe mounted on pile.
- b) As in specification 83.1212. The shoe shall have a centrally located hole with diameter corresponding to the drilling duct. The hole shall be filled with cured expanding mortar during driving operations.
- x) Quantity shall be measured as number of hollow shoes. Unit: pcs

83.1223 Delivery of hollow rock shoe with extended core

- a) Comprises delivery of hollow rock shoe with extended core mounted on pile.
- b) As in specification 83.1222. The supplementary length of the core shall be 40 ± 5 mm more than a normal shoe.
- x) Quantity shall be measured as number of hollow shoes. Unit: pcs

83.123 Bituminous coating on concrete piles

- a) Comprises delivery and application of bitumen and protective cover of paper as well as all extra costs during handling, driving, cutting operations etc. attributable to the bituminous coating.
- b) A primer is first applied followed by unoxidized bitumen.
- c) When the bitumen is applied the pile shall have a temperature of at least 10 O C. The bitumen shall only be applied on a dry pile surface after the surface has been properly cleaned.

Unless otherwise stated in *the special specifications* the bitumen coating shall have a minimum thickness of 2 mm with bitumen 70/100.

The applied coating shall be prevented from creep deformations by winding a strong paper band tightly around the pile. Measures shall be taken in order to prevent the coating from being scraped off during transportation/handling and pile driving.

- x) Quantity shall be measured as installed length of pile with bituminous coating. Unit: m

83.13 Rigging and positioning for concrete piles

- a) Comprises all costs associated with rigging/derigging of equipment related to the driving of concrete piles, including transfer of equipment on site and between and within pile groups.

Unless otherwise stated in *the special specifications*, the contractor may choose to perform the driving operations from the existing ground level or from an interim level. The specification also includes all actions and costs necessary to drive the piles from the selected level.

- b) The pile driving equipment shall provide a safe and stable guide for both pile hammer and pile. The tower shall have stable supports. It shall be possible to make adjustments to the tower inclination easily during driving operations. For operations on water, barges shall have sufficient buoyancy, stability and mooring. For piles driven below the water level it shall be possible to lower the bottom part of the tower for pile guidance unless a bottom guide frame is used.

Regarding driving equipment, see *the special specifications*. The choice of driving equipment and specification of net driving energy shall be presented to the Project Owner. It is the responsibility of the contractor to ensure that pile driving operations can be accomplished with the selected equipment.

- x) Costs shall be given as a lump sum. Unit: LS

83.131 Rigging for concrete piles

- a) Comprises transportation, rigging and derigging of machines and equipment necessary for driving concrete piles.

- x) Costs shall be given as a lump sum. Unit: LS

83.132 Additional costs for barges

- a) Comprises all additional costs for transportation, rigging and derigging of pile driving equipment on barges. The specification also covers all equipment the contractor finds necessary in order to carry out the piling operations from a safe working platform, like moorings, lines, winches, tug boats or other positioning systems in addition to the barge itself.

- x) Costs shall be given as a lump sum. Unit: LS

83.133 Rigging for pile groups

- a) Comprises transfer, rigging and precise positioning of piling machine/tower as well as all costs associated with establishing a basis for the precise positioning of piles.

- x) Quantity shall be measured as number of pile groups. Unit: pcs

83.134 Rigging supplement for pile groups below water

- a) Comprises all additional costs associated with manoeuvring of barges and positioning of equipment.
- x) Quantities shall be measured as number of pile groups. Unit: pcs

83.135 Additional costs for positioning below water

- a) Comprises additional work connected with positioning of piles below water. Applies to driving from a barge or where water cannot be removed from the construction pit due to high groundwater level or other geotechnical conditions.
- x) Quantity shall be measured as number of pile groups. Unit: pcs

83.14 Driving of concrete piles

- a) Comprises all deliveries or works resulting in completed, driven and cut piles not included in Specification 83.13.
- c) Concrete piles shall be driven by a hydraulic drop hammer. Other hammers may be used in agreement with the Project Owner.

Unless otherwise stated in *the special specifications* the weight of the drop hammer shall be in the range 50 – 80 kN so that it corresponds to the maximum weight of the driven pile (not considerably higher than but at least the same weight). When several pile types are involved, this applies to each pile type. Any deviation from this principle may only be made in agreement with the Project Owner.

A helmet shall be mounted on the pile head during driving. The helmet shall be made of steel and adapted to the pile so that proper guidance of the pile head is achieved.

During driving the blows shall be centred in relation to the pile and act in line with the longitudinal axis of the pile.

Driving with a follower is not permissible.

The inclination of the pile shall be checked during driving. If the pile has a tendency to alter inclination during driving, attempts shall not be made to correct this tendency after the pile has obtained lateral ground support.

The hammer drop height shall be adjusted to the pile length and piling resistance regarding stress levels in the pile. When driving in soft soils a maximum drop height of 15 cm shall be used and in firm soils/on bedrock maximum 30 cm unless otherwise stated in *the special specifications*. In case of doubt, PDA measurements shall be used to determine piling stresses, see specification 83.151.

- d) The level of the finished pile head shall not deviate more than ± 0.05 m from the design level.

The finished cut pile head shall not deviate more than 0.10 m from the design position in the horizontal plane unless otherwise stated.

Vertical piles shall have a maximum deviation of 2.5% from the plumb line and batter piles shall have a maximum deviation of 4% in all directions from the theoretical pile axis unless otherwise stated. Deviations shall not be systematic for several piles.

- x) As in Specification 83.12. Unit: m

83.141 Driving procedures for concrete piles

- a) Comprises driving and splicing (if applicable) of concrete piles. Up to 300 blows with penetration less than or equal to 4 mm per blow are included in the specification.

Additional costs for the number of blows in excess of 300 blows with penetration less than or equal to 4 mm per blow are included in specification 83.1451. The total number of blows is counted over the full pile length irrespective of the number of layers with penetration less than or equal to 4 mm per blow.

- c) When specified in *the special specifications* the piles shall be driven to a specified depth and driving shall be completed without any additional finishing blows.

The level of each pile head shall be measured immediately after driving is completed. Later the level of all piles in a pile group shall be checked before the piles are cut in order to determine whether further piling operations are required.

If the level check shows that any pile has heaved more than 5 cm, re-driving shall be performed, see specification 83.146. If specified in *the special specifications* or the Project Owner considers it necessary, piles shall be re-driven also where there is less heave or for other reasons. The piling process shall be performed in such a manner that any driven pile may be re-driven.

- x) As in Specification 83.12. Unit: m

83.142 Stop criteria in soils

- a) Comprises final part of pile driving of concrete piles in soils with up to 300 blows in series of 10 blows. Levelling of the head of each pile after driving is completed, and before cutting, is included in the specification.

Any blows in excess of 300 blows shall be covered by specification 83.1452.

- c) After the pile has been driven to a depth where the penetration is less than or equal to 4 mm per blow for the last 300 blows, stop criteria shall be checked. The final driving shall be performed in series of 10 blows. Pile penetration is measured for each series. Driving continues until the pile penetration per series for the given number of series is below the given limit (stop criteria). For stop criteria and requirements regarding applied blow energy see *the special specifications*.

During the final driving operations the pile penetration shall diminish or stay constant. If the penetration increases during this phase of the driving, the final driving is considered to have resumed when the penetration again diminishes and is less than or equal to 4 mm per blow for the last 300 blows.

There shall be no intermission in the pile driving or changing of helmet or cushion blocks just before or when checking the stop criteria.

Pile movements per blow shall be monitored for a representative series of blows in the final part of the driving. PDA measurements shall also be performed if stated in *the special specifications*, see specification 83.151.

Dynamic methods (driving formula and/or PDA measurements) shall be used to verify that the required characteristic bearing capacity has been achieved.

The level of each single pile head shall be measured immediately after the pile driving is completed. Later, the level of all piles in a pile group shall be checked before the piles are cut in order to determine whether further piling operations are required.

If the level check shows that any pile has heaved, redriving shall be performed, see specification 83.146. If specified in *the special specifications* or the Project Owner considers it necessary, redriving shall be performed regardless. The piling process shall be performed in such a manner that redriving may be performed on any driven pile.

- x) Quantity shall be measured as number of piles. Unit: pcs

83.143 Preparatory works for rock footings

- b) All piles in a pile group shall be driven to contact with the bedrock before the following tasks are performed.

83.1431 Rigging for drilling/installation of dowels

- a) Comprises all costs related to rigging for installation of dowels for concrete piles.

- x) Costs shall be given as a lump sum. Unit: LS

83.1432 Drilling for installation of dowels

- a) Comprises drilling for installation of dowels for rock shoes.

- b-c) When piles are driven to contact with bedrock, and before the rock shoe is hammered into the rock, 2 m deep holes shall be drilled into the rock as specified in *the special specifications*. Drill bits with diameters adjusted to both the internal diameter of the drilling duct in the pile (compare specification 83.1221) as well as the diameter of the dowel shall be used.

- x) Quantity shall be measured as number of drilled holes. Unit: pcs

83.1433 Delivery and installation of dowels

- a) Comprises delivery and installation of dowels.

- b) Dowels with diameter 50 mm and length 3 m shall be used or as specified in *the special specifications*. The steel grade shall be as specified in Table 83-1.

- c) Before a dowel is installed the borehole shall be checked for loose particles and cleaned if necessary. The hole is then filled with a suitable amount of grouting mortar and the dowel inserted to the bottom of the hole.

Hammering of the rock shoe into the bedrock to establish a rock footing shall be carried out according to specification 83.144 before the grout hardens. After the rock footing has been established the drilling duct in the remaining part of the pile shall be filled with mortar.

- x) Quantity shall be measured as number of piles with installed dowels. Unit: pcs

83.144 Establishing rock footings

- a) Comprises hammering of the rock shoe into the bedrock to establish a rock footing with up to 300 blows in series of 10 blows. Levelling of each pile head both after driving and before the pile is cut are included in the specification.

Any blows in excess of 300 blows are covered by specification 83.1453.

- c) When the pile shoe makes contact with the bedrock, the hammer drop height shall be reduced to 0.10 m in order to prevent skidding on inclined rock slopes. The drop height is then increased in steps of 0.10 m until a maximum height of 0.30 m is reached or as specified in *the special specifications*. For very short piles the maximum drop height shall be reduced and adjusted to driving stresses which if necessary shall be determined by use of PDA measurements, see specification 83.151.

The pile shall be chiselled until the penetration per series of blows is equal to or less than the criteria given in *the special specifications*, and the total chiselled depth into the bedrock is at least equal to the diameter of the rock shoe core or as specified in *the special specifications*.

Chiselling shall be performed in series of 10 blows. Pile penetration shall be measured for each series. Irrespective of penetration, a minimum of 10 series of blows shall be administered for each stage of hammer drop height.

When pile penetration per series diminishes or is constant and equal to or less than the chiselling criteria, the hammer drop height shall be increased to the next stage. This procedure shall be repeated until maximum drop height is reached. The chiselling procedure may be terminated when the penetration is diminishing or constant and equal to or less than the chiselling criteria for the last 5 blow series.

If the penetration in any phase of the chiselling procedure increases, the hammer drop height shall again be reduced, and the whole chiselling procedure repeated until the criteria are fulfilled.

If the required chiselling depth is not reached, the chiselling procedure shall be continued until a total number of 600 blows have been reached. The chiselling procedure may be terminated in agreement with the Project Owner if an overall evaluation indicates that a satisfactory rock footing has been achieved.

Pile movement monitoring shall be performed for one of the final blow series.

Dynamic methods (driving formula and/or PDA measurements) shall be used to verify that the required characteristic bearing capacity has been achieved.

The chiselling procedure shall be reconsidered and/or adjusted during the piling process if experience indicates that this is appropriate. This shall be decided in agreement with the Project Owner.

The level of each single pile head shall be measured immediately after the chiselling procedure is completed. Later the level of all piles in a pile group shall be checked before the piles are cut.

All piles shall be redriven, see specification 83.146. The contractor shall perform the piling process in such a manner that redriving may be performed on any pile.

- x) Quantity shall be measured as number of chiselled piles. Unit: pcs

83.145 Supplementary pile driving through hard layers/stop criteria/chiselling

- a) Comprises supplementary driving in excess of 300 blows included in specification 83.141, 83.142 and 83.144.
- x) Quantities shall be measured as number of series of 10 blows. Unit: pcs

83.1451 Driving through hard layers

- a) Comprises pile driving with penetration less than or equal to 4 mm per blow in excess of the 300 blows included in specification 83.141.
- b) Maximum pile driving energy shall be employed adjusted to driving stresses taking into account the pile type in question, pile length and driving resistance.
- c) The pile driving shall be performed in series of 10 blows or, as an alternative, continuously, but the driving resistance shall be observed and recorded for each series of 10 blows.
- x) Quantity shall be measured as number of series of 10 blows. Unit: pcs

83.1452 Supplementary driving to stop in soils

- a) Comprises supplementary driving to meet stop criteria in soils in addition to the 300 blows included in specification 83.142.
- c) As in specification 83.142.
- x) Quantity shall be measured as number of series of 10 blows. Unit: pcs

83.1453 Supplementary chiselling

- a) Comprises supplementary chiselling/final blows in excess of the 300 blows included in specification 83.144.
- c) As in specification 83.144.
- x) Quantity shall be measured as number of series of 10 blows. Unit: pcs

83.146 Redriving

- a) Comprises redriving of piles with up to 100 blows in series of 10 blows, see specifications 83.142 and 83.144. Levelling measurements of all piles after redriving are included in the specification. The specification also includes all costs for any new or modified piling rig for redriving purposes.

Redriving in excess of 100 blows is covered by specifications 83.1452 / 83.1453 if applicable.

- b) Redriving shall be performed with the same drop hammer that was used during the ordinary chiselling procedure/final blows. Another drop hammer may only be used in agreement with the Project Owner.
- c) Redriving shall be performed with a minimum of 5 series of 10 blows with the same drop height that was used in the final phase of the chiselling procedure/final blows, specifications 83.142 and 83.144.

Redriving shall be terminated when the penetration per series for the last series of 10 blows is equal to or less than the specified stop criteria (soils) or the chiselling criteria (rock), and the pile has reached the same level it had when the first part of the driving procedure was completed. The penetration shall diminish or be constant.

If this requirement is not satisfied a new redriving/chiselling procedure shall be performed, see specifications 83.142 and 83.144.

The level of each individual pile shall be measured immediately after redriving is completed. Unless otherwise agreed, documentation of pile positions shall be delivered to the Project Owner not later than 24 hours after redriving of a pile group has been completed. Later the level of each pile in the pile group shall be measured before the piles are cut.

Repeated redriving shall be performed if the Project Owner finds this necessary. The Project Owner may also decide if the extent of the redriving can be reduced if the results show that redriving does not seem necessary.

- x) Quantity shall be measured as number of redriven piles. Unit: pcs

83.15 Testing and control

83.151 Dynamic control measurements (PDA etc.)

- a) Comprises all materials, works and documentation related to dynamic control measurements.
- b) Dynamic control measurements shall be performed on a number of the first piles that are driven when starting the piling operations as specified in *the special specifications*. The object of the measurements is primarily to establish a corresponding data set for drop height, driving stresses, elastic deformations etc. for a given combination of pile driving equipment (hammer type)/pile type/ground conditions.

It is the responsibility of the contractor to employ the measurement data for performing further pile driving operations in an appropriate way with respect to the above mentioned factors and other requirements. In general the measurements shall be planned and performed so that the contractor may utilize the results. The measurement programme shall be submitted to the Project Owner.

The measurements may also be used for evaluation of bearing capacity.

If substantial changes in pile driving equipment, pile type, ground conditions or other special requirements occur, supplementary dynamic control measurements shall be performed. This shall be decided by the Project Owner on the basis of existing experience with the pile driving operations.

- c) Dynamic control measurements shall in general be performed as described in the Code of Practice for Piles 2005 (Peleveiledningen 2005) chapter 13.3 if relevant.

Pile movement monitoring shall be performed on a representative sample of blow series during the dynamic control measurements and in such a way that a coherent set of data may be easily established between measurement results and pile movements.

Through the measurement programme the pile shall, in as far as it is feasible, be followed through the soil penetration and establishment of rock footing or stop criteria in soil with the main focus on the final part of the pile driving. Measurements shall be performed for different drop height stages (driving energy) in order for coherent data sets to be established.

When not otherwise specified the measurement results shall be presented in a simple report containing as a minimum the following:

- pile identification
- type of driving equipment
- drop height (driving energy)
- driving stresses
- elastic deformations
- penetration
- estimated bearing capacity
- graph showing axial load versus time
- graph showing velocity versus time
- graph showing dynamic resistance versus permanent penetration

- x) Quantity shall be measured as number of completed measurement programmes. Unit: pcs
- 83.1511 Rigging for dynamic control measurements (PDA measurements)**
- a) Comprises all (preliminary) rigging and (final) derigging of equipment for dynamic control measurements as well as travelling time for operators.
 - x) Quantity shall be measured as number of completed measurement programmes. Unit: pcs
- 83.1512 Performance of dynamic control measurements (PDA measurements)**
- a) Comprises all costs related to dynamic control measurements on a single pile including mounting and demounting of sensors.

Reporting of measurement results is also included in the specification.
 - x) Quantity shall be measured as number of measured piles. Unit: pcs
- 83.152 Control of curvature**
- a) Comprises all materials and works as well as documentation in connection with curvature control on completed driven piles.
 - c) Control of curvature shall be performed as described in *the special specifications*.
 - x) Quantity shall be measured as number of measured piles. Unit: pcs
- 83.153 Loading tests**
- a) Comprises all materials and works as well as documentation in connection with loading tests on completed, driven piles.
 - c) Loading tests shall be performed as described in *the special specifications*.
 - x) Quantity shall be measured as number of load tested piles. Unit: pcs
- 83.16 Waiting time and operating time**
- a) Comprises unforeseen waiting time caused by the Project Owner. The specification also covers operating time that applies in connection with agreed extra work not covered by other specifications.
 - x) Quantity shall be measured as used time certified by the Project Owner. Unit: hours.
- 83.161 Waiting time for piling rig for concrete piles**
- a) Comprises unforeseen waiting time caused by the Project Owner. Disruption of piling works that in the opinion of the contractor warrant waiting time shall be communicated to the Project Owner immediately
 - x) Quantity shall be measured as waiting time certified by the Project Owner, maximum 8 hours per day. Unit: hours.
- 83.162 Operating time for piling rig for concrete piles**
- a) Comprises all operating costs for pile driving rig with necessary operators. The specification applies in cases of agreed additional work and special conditions not covered by unit prices.
 - x) Quantity shall be measured as operating time certified by the Project Owner. Unit: hour.
- 83.17 Completing works**
- b) Completed (final) pile and pile driving logs for all piles in a pile group shall be submitted to the Project Owner and the consent of the Project Owner shall be given before cutting of piles are performed and work on the pile head/foundation is started.
- 83.171 Cutting of concrete piles**
- a) Comprises cutting of concrete piles.
 - b) The cut-off surface shall be plane and at right angles to the longitudinal axis of the pile. The cut shall be made so that neither the pile below the cut nor the exposed reinforcing bars are damaged. The length of exposed reinforcement shall correspond at least to the minimum splicing distance for reinforcing bars according to NS 3475. Cutting through blasting operations is not permitted.
 - x) Quantity shall be measured as number of cut piles. Unit: pcs
- 83.1711 Cutting without exposure of reinforcing bars**
- 83.1712 Cutting with exposure of reinforcing bars**
- 83.2 Steel pipe piles (driven and drilled)**
- a) Comprises all deliveries and works resulting in completed installed and approved driven or bored steel pipe piles filled with concrete. The specification also covers additional site investigations that the contractor finds necessary in order to select pile lengths and accept the measuring rules given in point.
 - x). Noise reducing measures are also included if specified in *the special specifications*.

83.21 Preparatory and general works

83.211 Recording of pile logs

a-e) Complete pile and pile driving logs shall be recorded for all pile works with steel pipe piles.

The pile driving logs shall be recorded on the Public Roads Administration's form 473 or equivalent. An example on how the form shall be filled in is shown on page 241 in the Code of Practice for Piles 2005 (Peleveiledningen 2005).

Unless otherwise stated the pile driving logs shall be recorded continuously and submitted to the Project Owner on a daily basis, at the latest one day after the driving was performed. The logs shall be available for inspection at any time before it is submitted.

Complete (final) pile and pile driving logs for all piles in a pile group shall be submitted to the Project Owner before the piles are cut. See also specification 83.27/83.28.

The Project Owner shall be given reasonable time to evaluate and if necessary make check calculations on the pile group on the basis of the pile logs.

In addition the pile logs shall be duplicated and distributed as specified in *the special specifications* or as agreed with the Project Owner.

The pile driving logs shall at least contain the following:

- name of person in charge of the pile works
- name of foreman and the person responsible for recording logs
- identification of each pile
- pile type, cross-sectional area and material qualities
- accumulated length and length of each pile element
- type and length of pile shoe
- type of pile driving equipment – height of hammer drop, supplied energy and/or stroke frequency
- number of blows per metre and penetration per blow series
- movement monitoring
- drilling equipment
- deviations from specifications
- conditions that may influence the bearing capacity

The drilling logs shall at least contain the following:

- name of person in charge of the pile works
- name of foreman and the person responsible for recording logs
- pile number and date
- drilling system
- dimensions of equipment for drilling in soils and rock
- borehole depth and bottom level
- total length and length of pipe elements
- flushing pressure/water quantity
- irregularities during drilling
- soil layering
- description of soils/rock
- rate of penetration in rock
- result of borehole inspection
- recorded water levels
- measurements of water loss
- pressure grouting. Grouting pressure, volume of grout used as well as grout mix design shall be specified
- other relevant data for cost calculations and for evaluation of pile conditions and capacity.
- results from other control measurements as specified in *the special specifications*.

The final pile and pile driving logs shall also contain:

- all levelling measurements with dates, see specification 83.24 and sub-specifications.
- measured final position/inclination and direction as well as curvature if any
- special control measurements as specified in *the special specifications*
- calculated pile shoe level
- length of pile to be paid for

x) Costs shall be given as a lump sum. Unit: LS

83.212 Supplementary site investigations for steel pipe piles

a) Includes all work with supplementary site investigations.

b) The extent of the site investigations is determined by what the contractor considers necessary in order to determine pile lengths.

For assumed complicated site conditions supplementary site investigations may be performed in order to clarify project feasibility. The need for such investigations shall be decided in consultation with the Project Owner.

Choice of drilling method and performance shall be in accordance with Handbook 15 Field investigations. Quantity shall be measured as number of borehole metres. Unit: m

83.213 Noise reducing measures

- a) Comprises noise reducing measures as specified in *the special specifications*
- x) Costs shall be given as a lump sum. Unit: LS

83.214 Spudding/predrilling etc.

- a) Comprises spudding, predrilling or other means to penetrate hard layers/boulders.
- c) Reference is made to *the special specifications*
- x) Quantity shall be measured as number of metres of completed spudding. Unit: m

83.215 Measures for reducing soil displacement effects etc.

- a) Comprise measures in order to reduce soil displacement/remoulding or other adverse effects of the piling works.
- c) See *the special specifications*.
- x) Quantity shall be measured as actions taken for number of piles. Unit: pcs

83.22 Delivery of steel pipe piles and accessories

- a) Comprises delivery of all piles and accessories
- b) For pile type and bearing capacity requirements see *the special specifications*.

Piles shall be made of standardized steel in accordance with the requirements in Table 83-1.

The steel shall be marked in such a way that reference can be made to the certificate. Steel mill markings that will disappear when work is performed on steel elements (cutting etc.) shall be transferred. Transferred markings shall be documented. Steel certificates shall be presented at the latest one week before pile driving is performed and the certificate shall verify that the certificate and delivery are in agreement.

The end surfaces of pile elements shall be plane and at right angles to the longitudinal axis of the element.

Steel pipe piles that are driven to bedrock shall be provided with a rock shoe. The design of the rock shoe shall be in accordance with the Code of Practice for Piles 2005 (Peleveiledningen 2005) and otherwise as specified in *the special specifications*.

The core of the rock shoe shall consist of one unit (massive without splice). The tip of the rock shoe shall consist of tempered steel as specified in the Code of Practice for Piles 2005 (Peleveiledningen 2005) unless otherwise stated in *the special specifications*. The longitudinal axis of the pile and of the rock shoe tip shall be in line.

Piles shall be delivered with welded rock shoes in place, see specification 83.222.

Any surface treatment/corrosion protection shall be in accordance with *the special specifications*. Piles shall be transported and handled in such a way that the quality of the finished product is not impaired.

- d) Deviations from the secant line (curvature) shall not be greater than 0.1% measured with a 5 m straightedge, corresponding to a radius of curvature of minimum 625 m.

Pile ovality shall not be greater than 2% measured as $(d_{max} - d_{min}) \times 100/d$ Maximum permissible obliquity of pile element end surfaces is 1:500.

- x) Quantity shall be measured as completed length of steel pipe piles counting from the pile tip to the design cut-off level. Cut off parts and splices shall be included in the unit price. Unit: m

83.221 Delivery of pile elements

- a) Comprises procurement, transportation and storing of steel pipes.
- x) Quantities shall be measured as length of completed piles counting distances from the bottom of the pile pipe to the design cut-off level. Cut off parts and splices shall be included in the unit price. Unit: m

83.222 Delivery and mounting of pile shoes

- a) Comprises delivery and mounting of tip/shoe and any disposable drill bit as described in *the special specifications* if applicable.
- b) Pile shoes shall be produced at a certified workshop. This also applies to the splice between rock shoe and bottom pipe element. Welded bottom pipes shall have a minimum length of 2 m or as specified in *the special specifications*.

All welding works shall be inspected and documented. Welds between rock shoes and bottom pipes shall have the same inspection class as the rock shoe. Inspection classes are defined in Table 83-2.

Steel pipe piles with rock shoe shall always belong to the inspection class for bearing piles.

- x) Quantity shall be measured as number of pile shoes including welding to bottom pipe. Unit: pcs

83.2221 Delivery and mounting of massive rock shoes

- a) Comprises delivery and mounting of massive rock shoes as specified in *the special specifications*.

- x) Quantity shall be measured as number of rock shoes including welding to bottom pipe. Unit: pcs

83.2222 Delivery and mounting of hollow rock shoes

- a) Comprises delivery and mounting of hollow rock shoes as specified in *the special specifications*.

- b) When dowels are specified, piles shall have a hollow rock shoe with inner diameter 20 mm larger than the diameter of the dowel, see specification 83.2443.

- x) Quantity shall be measured as number of hollow rock shoes including welding to bottom pipe. Unit: pcs

83.2223 Delivery and mounting of soil shoes

- a) Comprises delivery and mounting of soil shoes on piles.

- x) Quantity shall be measured as number of soil shoes including welding to bottom pipe. Unit: pcs

83.2224 Delivery of disposable drill bits

- a) Comprises delivery of disposable drill bits for drilling of steel pipe piles.

- x) Quantity shall be measured as number of drill bits. Unit: pcs

83.223 Surface treatment of steel pipes

- a) Comprises delivery of materials and surface treatment for corrosion protection and/or reduction of negative skin friction forces.

- b-c) See *the special specifications*.

- x) Quantity shall be measured as completed length of surface treated piles. Unit: m

83.224 Cathodic protection of steel pipes

- a) Comprises all works and materials for cathodic protection of steel pipes.

- b-c) See *the special specifications*.

- x) Quantity shall be measured as number of piles. Unit: pcs

83.225 Inspection ducts on or in steel pipes

- a) Comprises all costs associated with the delivery and mounting of inspection ducts on/in steel pipes.

- b) The inspection duct shall be smooth on the inside, including splices, and positioned parallel to the longitudinal axis of the pile. Unless otherwise stated in *the special specifications*, square ducts with an inside width of 50 mm may be used.

The inspection duct may be fixed to the reinforcement before the concrete is poured.

Reference is also made to *the special specifications*.

- x) Quantity shall be measured as completed length of piles with inspection ducts. Unit: m

83.23 Rigging and positioning for steel pipe piles

- a) Comprises all costs associated with rigging for driving of steel pipe piles with drop hammers or vibro hammers, including equipment transfer and positioning for pile groups.

Alternatively the specification comprises drilling equipment with necessary accessories for drilling of steel pipe piles when this is specified in the project plans.

The pile driving equipment shall provide a safe and stable guide for both pile hammer and pile. The tower shall have stable supports. It shall be possible to make adjustments to the tower inclination easily during driving operations.

For operations on water the barge shall have sufficient buoyancy, stability and mooring. For piles driven below the water level it shall be possible to lower the bottom part of the tower for pile guidance unless a bottom guide frame or other positioning device is used.

For driving equipment see *the special specifications*. Choice of driving equipment and specification of net driving energy shall be presented to the Project Owner. This does not imply that the Project Owner has assumed responsibility for the feasibility of the pile driving operations with the selected equipment.

- x) Costs shall be given as a lump sum. Unit: LS

- 83.231 Rigging for driven steel pipe piles**
- a) Comprises transportation, rigging and derigging of machines and equipment necessary for driving steel pipe piles.
 - x) Costs shall be given as a lump sum. Unit: LS
- 83.232 Rigging for drilled steel pipe piles**
- a) Comprises transportation, rigging and derigging of machines and necessary equipment for drilling steel pipe piles.
 - x) Costs shall be given as a lump sum. Unit: LS
- 83.233 Rigging for driving on barge**
- a) Comprises all additional works and costs in connection with transportation, rigging and derigging of piling equipment on barges. The specification also covers all equipment the contractor finds necessary in order to carry out the piling operations from a safe working platform, such as moorings, lines, winches, tug boats or other positioning systems in addition to the barge itself.
 - x) Costs shall be given as a lump sum. Unit: LS
- 83.234 Positioning for pile group**
- a) Comprises transfer, rigging and precise positioning of piling machine/tower as well as all costs associated with establishing a surveying basis for the precise positioning of piles.
 - x) Quantity shall be measured as number of pile groups. Unit: pcs
- 83.235 Additional costs for positioning of pile groups below water**
- a) Comprises all additional costs associated with manoeuvring of barges and positioning of equipment.
 - x) Quantity shall be measured as number of pile groups. Unit: pcs
- 83.236 Additional costs for positioning below water**
- a) Comprises additional work connected with positioning of piles below water. Applies to driving from a barge or where water cannot be removed from the construction pit due to high groundwater level or other geotechnical conditions.
 - x) Quantity shall be measured as number of pile groups. Unit: pcs
- 83.24 Driving/drilling of steel pipe piles**
- a) Comprises all deliveries or works resulting in completed, driven/drilled and cut piles not included in Specification 83.23.
 - b) Driving of steel pipe piles shall be performed by a hydraulic drop hammer unless otherwise stated in *the special specifications*. Other hammers may be used in agreement with the Project Owner.

The weight of the drop hammer and net (effective) driving energy shall be as specified in *the special specifications*. If no detailed driving procedures are given in *the special specifications* the driving energy (drop height) shall be adjusted to the ground conditions and driving resistance in order to obtain the most effective penetration of the pile.

For large driving resistances the danger of overstressing (i.e. too high driving stresses) shall also be taken into account. If necessary, PDA measurements shall be used to clarify this, see specification 83.251.

Otherwise the driving energy shall be adjusted if this seems appropriate for other reasons. Such adjustments shall be made in agreement with the Project Owner.

Drilling of steel pipe piles shall be performed with drilling equipment as specified in *the special specifications*.
 - c) During driving a helmet shall be mounted on the pile head. The helmet shall be made of steel and fitted to the pile in order to obtain proper guidance for the pile head. Materials providing effective transmission of the driving energy shall be inserted in the upper part of the helmet during driving.

During driving the blows shall be centred and in line with the longitudinal axis of the pile.

The direction of the pile shall be controlled during driving/drilling. If a pile has a tendency to alter inclination during driving, attempts shall be made to prevent this if possible and appropriate. This shall be clarified in agreement with the Project Owner.

Buoyancy effects on the pile shall be taken into account. During driving closed pipe piles shall be filled with water to at least to a level corresponding to the water level outside the pile or to at least of the length of the pile in the driving rig.

When welding pipe pile elements, distinctions shall be made between steel pipe piles with and without the steel as a load carrying part of the completed structure, see *the special specifications*. Inspection classes are defined in Table 83-2.

Weld splicing shall be performed when 1.5 m of the pile remains above the ground level or working platform in order to ensure that the splice will be straight. The axes of the two pile sections shall be in line.

The same requirements and tolerances regarding end surfaces as specified in specification 83.22 apply to pile splicing and cutting.

The end surface of the upper pile shall be adjusted to make a 45° gore between the upper and lower pile. The distance between the upper and lower pile shall be sufficient for the weld to cover the end surfaces completely. The distance will vary depending on welding method and equipment. If piles are to be filled with concrete no objects shall be fixed to the pile that will reduce the cross-sectional area of the concrete.

- d) The following tolerance requirements apply to completed, driven or bored piles:
- maximum deviation from the plumb line is 2.5% for vertical piles
 - top level shall not deviate more than 50 mm from the design level
 - maximum permissible deviation from the design position in the horizontal plane is 100 mm
 - maximum deviation from theoretical pile axis is 4% in all directions for raking piles
 - maximum permissible directional change for splices is 1:250, measured along the longitudinal axis of the pile
 - minimum radius of curvature is 600 m

Tolerances and slope and directional deviations shall be measured along the longitudinal axis of the pile.

- x) As in specification 83.22. Unit: m

83.241 Driving procedures for steel pipe piles

- a) Comprises driving and splicing (if applicable) of steel pipe piles. Up to 300 blows with penetration less than or equal to 4 mm per blow are included in the specification.

Additional costs for number of blows in addition to 300 blows with penetration less than or equal to 4 mm per blow are included in specification 83.2461. The total number of blows is counted over the full pile length independently of the number of layers with penetration less than or equal to 4 mm per blow.

- c) When specified in *the special specifications* the piles shall be driven to a specified depth and driving shall be completed without any additional finishing blows.

The level of each single pile head shall be measured immediately after driving is completed. Later the level of all piles in a pile group shall be checked before the piles are cut in order to determine whether further piling operations are required.

If the level check shows that any pile has heaved more than 5 cm, further pile driving shall be performed, see specification 83.247. If specified in *the special specifications* or the Project Owner considers it necessary, piles shall be redriven also in the case of less heave or due to other reasons. The piling process shall be performed in such a manner that any driven pile may be redriven.

- x) As in specification 83.22. Unit: m

83.242 Drilling of steel pipe piles

- a) Comprises drilling and splicing, if applicable, of steel pipe piles as well as collecting, loading and transporting drill mud to an approved dump. Dump charges shall be included in the specification.

Drilling into rock is covered by specification 83.2452.

- x) As in specification 83.22. Unit: m

83.243 Stop criteria in soils

- a) Comprises final part of pile driving of steel pipe piles in soils with up to 300 blows in series of 10 blows. Levelling of the head of each pile after driving is completed and before cutting is included in the specification.

Any blows in excess of 300 blows shall be covered by specification 83.2462.

- b) After the pile has been driven to a depth where the penetration is less than or equal to 4 mm per blow for the last 300 blows, stop criteria shall be checked. The final driving shall be performed in series of 10 blows. Pile penetration shall be measured for each series. Driving shall continue until the pile penetration per series for the given number of series is below the given limit (stop criteria). For stop criteria and requirements regarding applied blow energy see *the special specifications*.

During the final driving operations the pile penetration shall diminish or stay constant. If the penetration increases during this phase of the driving, the final driving is considered to have been resumed when the penetration again diminishes and is less than or equal to 4 mm per blow for the last 300 blows.

There shall be no intermission in the pile driving or changing of helmet or cushion blocks when checking the stop criteria.

Pile movements per blow shall be monitored for a representative blow series in the final part of the driving. PDA shall also be performed if stated in *the special specifications*, see specification 83.251.

That the required characteristic bearing capacity is achieved shall be verified using dynamic methods (driving formula and/or PDA)

The level of each single pile head shall be measured immediately after the pile driving is completed. Later the level of all piles in a pile group shall be checked before the piles are cut in order to determine whether further piling operations are required.

If the level check shows that any pile has heaved, further pile driving shall be performed, see specification 83.247. If specified in *the special specifications* or the Project Owner considers it necessary, piles shall be redriven regardless. The piling process shall be performed in such a manner that any driven pile may be redriven.

- x) Quantity shall be measured as number of piles. Unit: pcs

83.244 Preparatory works for rock footings

83.2442 Rigging for predrilling in rock for pile shoes

- a) Comprises all rigging and predrilling costs in rock for pile shoes.
- b) Costs shall be given as a lump sum. Unit: LS

83.2442 Predrilling in rock for pile shoes

- a) Comprises all costs related to predrilling in rock for pile shoes.
- b) When piles are driven to contact with the bedrock, and before the rock shoe is hammered into the rock, predrilling shall be performed to a depth corresponding to the diameter of the rock shoe core. The object is to facilitate the penetration of the shoe into the bedrock and subsequent chiselling operations. A drill bit with the largest possible diameter in relation to the inner diameter of the rock shoe shall be used.
- x) Quantity shall be measured as number of predrilled piles. Unit: pcs

83.2443 Rigging for drilling/installation of dowels

- a) Comprises all costs related to rigging for installation of dowels for steel pipe piles.
- x) Costs shall be given as a lump sum. Unit: LS

83.2444 Drilling for installation of dowels

- a) Comprises all works and materials in connection with drilling for installation of dowels for rock shoes.
- b) When piles are driven to contact with the bedrock, and before the rock shoe is hammered into the rock, 2 m deep holes shall be drilled into the rock as specified in *the special specifications*. Drill bits with diameters adjusted to both the internal diameter of the rock shoe and the diameter of the dowel shall be used.
- x) Quantity shall be measured as number of piles with dowels. Unit: pcs

83.2445 Delivery and installation of dowels

- a) Comprises delivery and installation of dowels as specified in *the special specifications*.
- b) All piles in a pile group shall be driven to contact with the bedrock before work with dowel installations are performed. The dowel diameter shall be 80 mm or larger if specified in *the special specifications*.

The length of the dowel shall be 3 m or as specified in *the special specifications*. The steel grade shall be as specified in Table 83-1.

- c) Before the dowel is installed the borehole shall be checked for loose particles and cleaned if necessary. The hole is then filled with a suitable amount of grouting mortar through a hose before the dowel is inserted to the bottom of the hole.

Chiselling of rock footing in accordance with specification 83.2451 shall be performed before the mortar hardens.

- x) Quantity shall be measured as number of piles with dowels. Unit: pcs

83.245 Chiselling/stop criteria and drilling in rock

83.2451 Chiselling/stop criteria in rock

- a) Comprises chiselling of the rock shoe into the bedrock to establish a rock footing with up to 300 blows in series of 10 blows. Levelling of each pile head both after driving and before the pile is cut are included in the specification.

The number of blows in excess of 300 blows is covered by specification 83.2463.

- c) After any predrilling and dowel installation has been completed, chiselling of rock footing shall be performed. Steel pipe piles shall be filled with water during the chiselling process.

Chiselling of rock footing shall be performed with stepwise increases in driving energy. When the pile shoe makes contact with the bedrock the hammer drop height shall be reduced to the lowest step in order to prevent skidding on inclined rock slopes. Unless otherwise stated in *the special specifications* the driving energy shall then be increased according to the following scale, where the full energy is defined as the net driving energy specified in specification 83.24.

step 1: approx.	15% of full energy	-	min. 10 series
step 2: approx.	30% of full energy	-	min. 10 series
step 3: approx.	50% of full energy	-	min. 5 series
step 4: approx.	75% of full energy	-	min. 5 series
control: approx.	100% of full energy	-	min. 1 series

The pile shall be chiselled into the rock until the penetration per series of blows is equal to or less than the criterion in *the special specifications* (normally 1-3 mm per series), and the total chiselled depth into the bedrock is at least equal to the diameter of the rock shoe core or as specified in *the special specifications*.

Chiselling shall be performed in series of 10 blows and pile penetration shall be measured for each series. Irrespective of pile penetration, a minimum number of blow series per energy step shall be applied as specified above.

When pile penetration per series diminishes or is constant and equal to or less than the chiselling criteria, the hammer drop height shall be increased to the next step and the procedure shall be repeated until the last step is reached. The chiselling procedure may be terminated when the penetration is diminishing or constant and equal to or less than the chiselling criteria for the last 5 blow series.

If the penetration in any phase of the chiselling procedure increases, the hammer drop height shall again be reduced, and the whole chiselling procedure repeated until the criteria are fulfilled.

If the required chiselling depth is not reached, the chiselling procedure shall be continued until a total number of 1000 blows has been reached. The chiselling procedure may be terminated in agreement with the Project Owner if an overall evaluation indicates that a satisfactory rock footing has been achieved.

Following the last stage, 10 control blows shall be applied for verification of characteristic load capacity according to driving formulae or other dynamic methods (PDA).

Pile movement monitoring shall be performed for one of the final blow series and on the last series for verification of load capacity.

The chiselling procedure shall be reconsidered and/or adjusted during the piling process if experience indicates that this is appropriate. This shall be decided in agreement with the Project Owner.

The level of each pile head shall be measured immediately after the chiselling procedure is completed. Later the level of all piles in a pile group shall be checked before the piles are cut.

All piles shall be redriven, see specification 83.247. This does not apply to piles with dowels. For other piles the piling process shall be carried out in such a manner that redriving may be performed on any pile.

- x) Quantity shall be measured as number of piles with chiselled footing. Unit: pcs

83.2452 Drilling in rock

- a) Comprises drilling of steel pipes and establishing of rock footing.
- c) Drilling as specified in *the special specifications*.
- x) Quantity shall be measured as number of drilled pile footings. Unit: pcs

83.246 Supplementary pile driving through hard layers/chiselling/stop criteria

- a) Comprises supplementary blows in excess of the 300 blows in specifications 83.241, 83.243 and 83.2451.

83.2461 Driving through hard layers

- a) Comprises pile driving with penetration less than or equal to 4 mm per blow in excess of the 300 blows included in specification 83.241.
- b) As a minimum, 70% of the net (effective) driving energy required in specification 83.24 shall be used. Otherwise as stated in specification 83.24.
- c) The pile driving shall be performed in series of 10 blows or, as an alternative, continuously, but the driving resistance shall be observed and recorded for each series of 10 blows
- x) Quantity shall be measured as number of series of 10 blows. Unit: pcs

83.2462 Supplementary driving to stop in soils

- a) Comprises supplementary driving to meet stop criteria in soils in excess of the 300 blows covered by specification 83.243.
- c) As in specification 83.243.
- x) Quantity shall be measured as number of series of 10 blows. Unit: pcs

83.2463 Supplementary chiselling

- a) Comprises supplementary chiselling/final blows in excess of the 300 blows included in specification 83.2451.
- c) As in specification 83.2451.
- x) Quantity shall be measured as number of series of 10 blows. Unit: pcs

83.247 Redriving

- a) Comprises redriving of piles with up to 100 blows in series of 10 blows, see specifications 83.243 and 83.2451. Levelling measurements of all piles after redriving are included in the specification. The specification also includes all costs for any new or modified piling rig for redriving purposes.

Redriving in excess of 100 blows shall be covered by specifications 83.1452 / 83.1453 if applicable

- b) Redriving shall be performed with the same drop hammer that was used during the ordinary chiselling procedure/final blows. Another drop hammer may only be used in agreement with the Project Owner.
- c) Redriving shall be performed with a minimum of 5 series of 10 blows with the same drop height that was used in the final phase of the chiselling procedure/final blows, specifications 83.243 and 83.2451.

Redriving shall be terminated when the penetration per series for the last series of 10 blows is equal to or less than the specified stop criteria (soils) or the chiselling criteria (rock) as specified in the specifications 83.243 and 83.2451, and the pile has reached the same level it had when the first part of the driving procedure was completed. The penetration shall diminish or be constant.

If this requirement is not satisfied a new redriving/chiselling procedure shall be performed.

The level of each individual pile shall be measured immediately after redriving is completed. Unless otherwise agreed, documentation of pile positions shall be submitted to the Project Owner not later than 24 hours after redriving of a pile group has been completed. Later the level of each pile in the pile group shall be measured before the piles are cut.

Repeated redriving shall be performed if the Project Owner finds this necessary. The Project Owner may also decide if the extent of the redriving can be reduced if the results show that redriving does not seem necessary.

- x) Quantity shall be measured as number or redriven piles. Unit: pcs

83.25 Testing and inspection

- a) Comprises all materials, works and documentation related to testing and inspection activities not included in specifications 83.2 - 83.247.

83.251 Dynamic control measurements (PDA measurements etc.)

- a) Comprises all materials, works and documentation related to dynamic control measurements.
- b) Dynamic control measurements shall be performed on a number of piles as specified in *the special specifications* among the first piles that are driven when starting the piling operations. The object of the measurements is primarily to establish a corresponding data set for drop height, driving stresses, elastic deformations etc. for a given combination of pile driving equipment (hammer type)/pile type/ground conditions.

It is the responsibility of the contractor to employ the measurement data for performing further pile driving operations in an appropriate way with respect to the above mentioned factors and other requirements. In general the measurements shall be planned and performed so that the contractor may utilize the results. The measurement programme shall be submitted to the Project Owner.

The measurements may also be used for evaluation of bearing capacity.

If substantial changes in pile driving equipment, pile type, ground conditions or other special requirements occur, supplementary dynamic control measurements shall be performed. This shall be decided by the Project Owner on the basis of existing experience with the pile diving operations.

- c) Dynamic control measurements shall in general be performed as described in the Code of Practice for Piles 2005 (Peleveiledningen 2005) chapter 13.3 if relevant

Pile movement monitoring shall be performed on a representative sample of blow series during the dynamic control measurements and in such a way that a coherent set of data may be easily established between measurement results and pile movements.

Through the measurement programme the pile shall, if practically possible, be followed through the soil penetration and establishment of rock footing or stop criteria with the main focus on the final part of the pile driving. Measurements shall be performed for different stages in drop heights (driving energy) in order for coherent data sets to be established.

Unless otherwise specified the measurement results shall be presented in a simple report containing as a minimum the following:

- pile identification
- type of driving equipment
- drop height (driving energy)
- driving stresses
- elastic deformations
- penetration
- estimated bearing capacity
- graph showing axial load versus time
- graph showing velocity versus time
- graph showing dynamic resistance versus permanent penetration

- x) Quantity shall be measured as number of measurement programmes performed. Unit: pcs

83.2511 Rigging for dynamic control measurements (PDA)

- a) Comprises all (preliminary) rigging and (final) derigging of equipment for dynamic control measurements as well as travelling time for operators.

- x) Quantity shall be measured as number of measurement programmes performed. Unit: pcs

83.2512 Performance of dynamic control measurements (PDA)

- a) Comprises all costs related to dynamic control measurements on a single pile including mounting and dismantling of sensors.

Reporting of measurement results is also included in the specification.

- x) Quantity shall be measured as number of measured piles. Unit: pcs

83.252 Control of curvature

- a) Comprises all works related to curvature measurements of steel pipes before concrete is poured.

- c) See *the special specifications*.

- x) Quantity shall be measured as number of controlled piles. Unit: pcs

83.253 Inspection of steel pipe pile filled with concrete

- a) Comprises all works and materials related to inspection of steel pipe piles filled with concrete through mounted inspection duct.

- c) See *the special specifications*.

- x) Quantity shall be measured as number of inspected piles. Unit: pcs.

83.254 Loading tests

- a) Comprises all materials and works as well as documentation in connection with loading tests on steel pipe piles.

- c) Loading tests shall be performed as described in *the special specifications*.

- x) Quantity shall be measured as number of load tested piles. Unit: pcs

83.26 Waiting time and operating time

- a) Comprises unforeseen waiting time caused by the Project Owner. Furthermore the specification comprises operating time that applies in connection with agreed extra work not covered by other specifications.

- x) Quantity shall be measured as used time certified by the Project Owner. Unit: hours.

83.261 Waiting time for piling rig for steel pipe piles

- a) Comprises unforeseen waiting time caused by the Project Owner. Disruption of works that in the opinion of the contractor warrant waiting time shall be communicated to the Project Owner immediately.

- x) Quantity shall be measured as waiting time certified by the Project Owner, maximum 8 hours per day. Unit: hours.

83.262 Operating time for piling rig for steel pipe piles

- a) Comprises all operating costs for pile driving rig with necessary operators. The specification applies in cases of agreed additional work and special conditions not covered by unit prices.

- x) Quantity shall be measured as operating time certified by the Project Owner. Unit: hour.

83.27 Completing works

- b) Completed (final) pile and pile driving logs including position measurements for all piles in a pile group shall be submitted to the Project Owner and the consent of the Project Owner shall be given before cutting of piles is performed and work on reinforcement installations and the casting process is initiated.

83.271 Cutting of steel pipe piles

- a) Comprises cutting of steel pipe piles as well as delivery and mounting of pile heads according to *the special specifications*.
- x) Quantity shall be measured as number of piles. Unit: pcs

83.28 Reinforcing and casting of concrete for steel pipe piles

- b) The positions of the piles shall be rechecked after reinforcement has been positioned and concrete poured and the results shall be entered in the pile logs. The consent of the Project Owner shall be available before works with the pile head/foundation are initiated.

83.281 Reinforcement

- a-e) Reinforcement in steel pipe piles shall satisfy the requirements of specification 84.3.

The reinforcement shall normally be consist of prefabricated cages fixed by welds at the intersecting points. The welding shall be performed in accordance with requirements in specification 84.3 c). Precisely dimensioned steel rings may be used inside the main reinforcement as mounting guides. Mounting guides shall not be used outside the main reinforcement.

In order to secure sufficient reinforcement cover particularly suitable reinforcement spacers made of hard plastic material shall be used to prevent direct metallic contact between the reinforcement and the steel pipe. The distance between the reinforcement spacers shall be decided on the basis of the weight and stiffness of the reinforcement cage and pile inclination. As a minimum 4 spacers shall be used per 2 m length of pile, evenly distributed around the pile perimeter. See Internal report No. 1560 from the Norwegian Road Research Laboratory or later versions replacing this report.

- x) As in specification 84.3. The specification also includes materials and works related to splicing of reinforcement cages. Unit: ton

83.282 Casting

- a) Comprises delivery and pouring of concrete and protection of concrete against adverse effects during transportation, temporary storage, casting and curing as well as necessary finishing works

The specification also includes preparations and control before the pouring process like dewatering, pile loading prior to dewatering, cleaning of sludge from the pipe, watertightness etc.

- b) Pouring of concrete in a closed steel pipe piles shall in general be performed under dry conditions. Permissible amounts of water in this connection shall not be greater than a volume corresponding to 10 mm multiplied by the cross-sectional area of the pile.

When appropriate, concrete may also be cast below water according to agreement with the Project Owner. Open steel pipe piles shall be cast as specified in *the special specifications*.

Concrete for dry-casting shall be in accordance with specification 84.4, concrete specification SV-40 with the exception that the amount of silica additives may be increased by up to 8%. Concrete for casting below water, normal concrete and AWO concrete shall be in accordance with specification 84.43.

- c) When dry-casting, the upper 3 m of the pile shall be compacted with an immersion vibrator. See Internal report No. 1560 from the Norwegian Road Research Laboratory (Veglaboriet) or later versions replacing this report. Requirements regarding choice of materials, work performance and work extent presented in this report, applies unless otherwise stated in *the special specifications*.

When casting below water, the 3 m bottom length of the pile shall be cast with AWO concrete using a submerged casting pipe. Underwater concrete may be used for the remainder of the pile. Procedures shall be as specified in *the special specifications*.

- d-e) As in specification 84.4.

- x) As in specification 84.4. Unit: m³

83.3 Solid steel piles (steel sections)

- a) Comprises deliveries and works resulting in completed installed and approved driven/chiselled steel pipe piles, with dowels if applicable, including any supplementary site investigations the contractor finds necessary to enable him to decide on pile lengths and to accept the measuring rules in point x). Noise reducing measures are also included if specified in *the special specifications*.

83.31 Preparatory and general works

83.311 Recording of pile and pile driving logs

- a-e) Complete pile and pile driving logs shall be recorded for all works with steel piles. The pile driving logs shall be recorded on the Public Roads Administration's form 473 or equivalent. An example of how the form shall be filled in is shown on page 241 of the Code of Practice for Piles 2005 (Peleveiledningen 2005).

Unless otherwise stated, the pile driving logs shall be recorded continuously and submitted to the Project Owner on a daily basis, at the latest one day after the driving was performed. The logs shall be available for inspection at any time before they are submitted.

Complete (final) pile and pile driving logs for all piles in a pile group shall be submitted to the Project Owner before the piles are cut. See also specification 83.37.

The Project Owner shall be given reasonable time to evaluate and if necessary verify calculations on the pile group on the basis of the pile logs.

In addition the pile logs shall be duplicated and distributed as specified in *the special specifications* or as agreed with the Project Owner.

The pile driving logs shall at least contain the following:

- name of person in charge of the pile works
- name of foreman and the person responsible for recording logs
- identification of each pile
- pile type, cross-sectional area and material qualities
- total length and length of each pile element
- type and length of pile shoe
- type of pile driving equipment – height of hammer drop, supplied energy and/or stroke frequency
- number of blows per metre and penetration per blow series
- movement monitoring
- deviations from specifications
- conditions that may influence the bearing capacity

The final pile and pile driving logs shall also contain:

- all levelling measurements with dates, see specification 83.34 and sub-specifications.
- measured final position/inclination and direction as well as curvature if any
- special control measurements as specified in *the special specifications*
- calculated pile shoe level
- length of pile to be paid for

- x) Costs shall be given as a lump sum. Unit: LS

83.312 Supplementary site investigations for steel piles

- a) Includes all work with supplementary site investigations.
- b) The extent of the site investigations is determined by what the contractor considers necessary in order to determine pile lengths.
- c) Choice of drilling method and performance shall be in accordance with Handbook 15 Field investigations (Feltundersøkelser).
- x) Quantity shall be measured as number of borehole metres. Unit: m

83.313 Noise reducing measures

- a) Comprises noise reducing measures as specified in *the special specifications*
- x) Costs shall be given as a lump sum. Unit: LS

83.314 Spudding

- a) Comprises spudding as specified in *the special specifications*
- x) Quantity shall be measured as number of metres of spudding. Unit: m

83.315 Measures for reducing soil displacement etc.

- a) Comprises measures for reducing soil displacement/remoulding or other unwanted effects of the pile driving.
- c) See *the special specifications*.
- x) Quantity shall be measured as implemented measures to number of piles. Unit: pcs

83.32 Delivery of steel piles and accessories

- a) Comprises delivery of piles and accessories
- b) For pile type and bearing capacity requirements see the special contract specifications

Piles shall be made of standardized steel in accordance with the requirements in Table 83-1.

The piles shall be transported, handled and stored in such a way that the quality of the finished product is not impaired. The piles shall be stored and marked so that no confusion may arise regarding different steel types and grades. Steel piles driven to contact with the bedrock shall be fitted with a rock shoe. The longitudinal axes of the pile and the shoe shall be in line. The length and form of the rock shoe shall

be adjusted to the rock slope. The shape and hardness of the rock shoe shall be as described in the Code of Practice for Piles 2005 (Peleviledningen 2005) or in *the special specifications*.

Surface treatments/corrosion protection shall be in accordance with *the special specifications*. The piles shall be delivered with weld mounted shoes. This work shall be performed at a certified workshop.

- d) Deviations from the secant line (curvature) shall not be greater than 0.1% measured with a 5 m straightedge. This corresponds to a radius of curvature of minimum 625 m.
- x) Quantity shall be measured as completed length of steel piles, measured from the pile shoe to the design cut-off level. Cut-off lengths and splices shall be included in the unit price. Unit: m

83.321 Delivery of pile elements

- a) Comprises delivery of pile elements without pile shoe
- x) Quantity shall be measured as completed length of steel piles, measured from the bottom of the steel section to the design cut-off level. Cut-off parts and splices shall be included in the unit price. Unit: m

83.322 Delivery and mounting of pile shoes

- a) Comprises delivery and mounting of pile shoes of the type(s) specified in *the special specifications*.
- x) Quantity shall be measured as number of pile shoes. Unit: pcs

83.3221 Delivery and mounting of solid rock shoes

- a) Comprises delivery of rock shoe as specified in *the special specifications*, mounted on pile.
- x) Quantity shall be measured as number of rock shoes. Unit: pcs

83.3222 Delivery and mounting of soil shoes

- a) Comprises delivery of soil shoes as specified in *the special specifications* and mounted on pile.
- x) Quantity shall be measured as number of soil shoes. Unit: pcs

83.323 Delivery and mounting of pile head

- a) Comprises delivery and mounting of pile head as specified in *the special specifications*.
- x) Quantity shall be measured as number of pile heads. Unit: pcs

83.324 Surface treatment of steel piles

- a) Comprises delivery of materials and surface treatment for corrosion protection and/or reduction of negative skin friction forces.
- b-c) See *the special specifications*.
- x) Quantity shall be measured as completed length of surface-treated piles. Unit: m

83.325 Inspection ducts on steel piles

- a) Comprises all costs associated with the delivery and mounting of inspection ducts on steel piles.
- c) The inspection duct shall be smooth on the inside, including splices, and positioned parallel to the longitudinal axis of the pile. Unless otherwise stated in *the special specifications*, square ducts with an inside width of 50 mm may be used. The duct shall be positioned in the corner between web and flange and welded to the pile as specified in *the special specifications*.
- x) Quantity shall be measured as completed length of piles with inspection duct. Unit: m

83.326 Cathodic protection of steel piles

- a) Comprises all costs in connection with cathodic protection of steel piles.
- c) See *the special specifications*.
- x) Quantity shall be measured as number of piles. Unit: pcs

83.33 Rigging and positioning of steel piles

- a) Comprises all costs in connection with rigging for driving steel piles with drop hammer or vibro hammer including positioning of pile groups.
- b) The piling rig shall provide safe and stable guidance for drop hammer and pile. The tower shall have stable supports. It shall be possible to make adjustments to the tower inclination easily during driving operations. For operations on water the barge shall have sufficient buoyancy, stability and mooring. For piles driven below the water level it shall be possible to lower the bottom part of the tower for pile guidance unless a bottom guide frame or other positioning device is used.

For driving equipment see *the special specifications*. The driving equipment chosen with specification of net driving energy shall be presented to the Project Owner. This does not imply that the Project Owner assumes responsibility for the feasibility of pile driving operations with the chosen equipment.

For driving equipment see *the special specifications*. The driving equipment chosen with specification of net driving energy shall be presented to the Project Owner. It is the responsibility of the contractor that the pile driving operations may be accomplished with the chosen equipment.

- x) Costs shall be given as a lump sum. Unit: LS

83.331 Rigging for steel piles

- a) Comprises transportation, rigging and derigging of machines and equipment necessary for driving steel piles.
- x) Costs shall be given as a lump sum. Unit: LS

83.332 Additional costs for rig on barges

- a) Comprises all additional costs in connection with transportation, rigging and derigging of piling equipment on barges. The specification also covers all equipment the contractor finds necessary in order to carry out the piling operations from a safe working platform, such as moorings, lines, winches, tug boats or other positioning systems in addition to the barge itself.
- x) Costs shall be given as a lump sum. Unit: LS

83.333 Positioning for pile group

- a) Comprises rigging, transfer and precise positioning of piling machine/tower as well as all costs associated with establishing a surveying basis for the precise positioning of piles.
- x) Quantities shall be measured as number of pile groups. Unit: pcs

83.334 Additional costs for positioning of pile group below water

- a) Comprises all additional costs associated with manoeuvring of a barge and positioning of equipment on a barge.
- x) Quantities shall be measured as number of pile groups. Unit: pcs

83.335 Additional costs for positioning below water

- a) Comprises additional work connected with positioning of piles below water. Applies to driving from a barge or where water cannot be removed from the construction pit due to high groundwater level or other geotechnical conditions.
- x) Quantity shall be measured as number of pile groups. Unit: pcs

83.34 Driving of steel pipe piles

- a) Comprises all deliveries or works resulting in completed, driven/drilled and cut piles not covered by Specification 83.33.
- c) The weight of the drop hammer and drop height shall be as specified in *the special specifications*. Other hammers may be used in agreement with the Project Owner.

When vibro hammers are used, requirements regarding the equipment shall be specified in *the special specifications*.

Driving with a follower is not permissible.

During driving the blows shall be centred and aligned with the longitudinal axis of the pile.

The direction of the pile shall be controlled during driving. If the pile has a tendency to alter inclination during driving, attempts shall not be made to correct this tendency after the pile has obtained lateral ground support.

The hammer drop height shall be as specified in *the special specifications*. However, the drop height shall be adjusted if the pile penetration changes suddenly. Any increases in drop height shall be in agreement with the Project Owner. The risk of overstressing the pile shall be considered in each case. See *the special specifications*.

During driving a helmet shall be mounted on the pile head. The helmet shall be made of steel and fitted to the pile in order to obtain proper guidance for the pile head.

- d) The level of the pile head shall not deviate more than ± 0.05 m from the design level. If the pile is driven or cut too low, the bottom level of the foundation may be lowered accordingly in agreement with the Project Owner.

The completed, cut pile head shall not deviate more than 0.10 m from the design position in the horizontal plane unless otherwise specified.

Vertical piles shall have a maximum deviation of 2.5% from the plumb line and batter piles shall have a maximum deviation of 4% in all directions from the theoretical pile axis unless otherwise stated. Deviations shall not be systematic for several piles.

- x) As in specification 83.32. Unit: m

83.341 Driving procedures for steel piles

- a) Comprises driving and splicing (if applicable) of steel pipe piles. Up to 300 blows with penetration less than or equal to 4 mm per blow are included in the specification.

Additional costs for blows in excess of 300 blows with penetration less than or equal to 4 mm per blow are covered by specification 83.3451. The total number of blows is counted over the full pile length irrespective of the number of layers with penetration less than or equal to 4 mm per blow.

- c) When specified in *the special specifications*, the piles shall be driven to a specified depth and driving shall be completed without any additional finishing blows.

The level of each pile head shall be measured immediately after driving is completed. Later the level of all piles in a pile group shall be checked before the piles are cut in order to determine whether further piling operations are required.

If the level check shows that any pile has heaved more than 5 cm, further pile driving shall be performed, see specification 83.346. If specified in *the special specifications* or if the Project Owner considers it necessary, piles may be redriven also in the case of less heave or for other reasons. The piling process shall be performed in such a manner that any driven pile may be redriven.

- x) As in specification 83.32. Unit: m

83.342 Stop criteria in soils

- a) Comprises the final part of pile driving of steel piles in soils with up to 300 blows in series of 10 blows. Levelling of the head of each pile after driving is completed and before cutting is included in the specification.

Any blows in excess of 300 blows shall be covered by specification 83.3452.

- c) After the pile has been driven to a depth where the penetration is less than or equal to 4 mm per blow for the last 300 blows, stop criteria shall be checked. The final driving shall be performed in series of 10 blows. Pile penetration is measured for each series. Driving continues until the pile penetration per series for the given number of series is below the given limit (stop criteria). For stop criteria and requirements regarding applied blow energy see *the special specifications*.

During the final driving operations the pile penetration shall diminish or stay constant. If the penetration increases during this phase of the driving, the final driving is considered to have been resumed when the penetration again diminishes and is less than or equal to 4 mm per blow for the last 300 blows.

There shall be no intermission in the pile driving or changing of helmet or cushion blocks when checking the stop criteria.

Pile movements per blow shall be monitored for a representative blow series in the final part of the driving. PDA shall also be performed if specified in *the special specifications*, see specification 83.351.

Dynamic methods (driving formula and/or PDA) shall be used to verify that the required characteristic bearing capacity is achieved.

The level of each pile head shall be measured immediately after the pile driving is completed. Later the level of all piles in a pile group shall be checked before the piles are cut in order to determine whether further piling operations are required.

If the level check shows that any pile has heaved, further pile driving shall be performed, see specification 83.346. If specified in *the special specifications* or the Project Owner considers it necessary, piles shall be redriven regardless. The piling process shall be performed in such a manner that any driven pile may be redriven.

- x) Quantity shall be measured as number of piles. Unit: pcs

83.343 Predrilling in rock for pile shoe

- a) Comprises predrilling for rock shoe as specified in *the special specifications*.

- x) Quantity shall be measured as number of drilled holes. Unit: pcs

83.344 Chiselling/stop criteria in rock

- a) Comprises chiselling of steel piles into the bedrock to establish a rock footing with up to 300 blows in series of 10 blows. Levelling of each pile head both after driving and before the pile is cut is included in the specification.

Blows in excess of 300 blows are covered by specification 83.3453.

- c) When the pile shoe makes contact with the bedrock the hammer drop height shall be reduced to 0.10 m in order to prevent skidding on inclined rock slopes. The drop height shall then be increased in steps. A minimum of 10 series of blows shall be performed for each step. Chiselling shall continue until the penetration per blow series is less than the chiselling criteria specified in *the special specifications*, and the chiselled depth into the bedrock is at least as large as that specified in *the special specifications*

Chiselling shall be performed in series of 10 blows. Pile penetration shall be measured for each series.

If pile penetration per 10 series of 10 blows diminishes or is constant for a drop height of 0.10 m and less than the chiselling criteria, the hammer drop height shall be increased in steps. The drop height, unless otherwise specified, shall be kept below the maximum permissible height for the pile type in question. If the pile penetration per 10 series of 10 blows continues to diminish or remains constant for the increased drop height, chiselling shall continue until both the chiselling criteria and the total rock penetration depth are achieved. Pile movement monitoring shall be performed.

If the penetration in any phase of the chiselling procedure increases, the hammer drop height shall again be reduced, and the whole chiselling procedure repeated until the criteria are fulfilled.

Dynamic methods (driving formula and/or PDA) shall be used to verify that the required characteristic bearing capacity has been achieved.

The level of each pile head shall be measured immediately after the chiselling procedure is completed. Later the level of all piles in a pile group shall be checked before the piles are cut.

All piles shall be redriven, see specification 83.346. The contractor shall perform the piling process in such a manner that redriving may be performed on any pile.

- x) Quantity shall be measured as number of chiselled piles. Unit: pcs

83.345 Supplementary pile driving through hard layers/stop criteria/chiselling

- a) Comprises supplementary driving in excess of 300 blows included in specifications 83.341, 83.342, 83.344.

83.3451 Driving through hard layers

- a) Comprises pile driving with penetration less than or equal to 4 mm per blow in excess of the 300 blows included in specification 83.341.
- b) As a minimum 70% of the net (effective) driving energy as required in specification 83.34 shall be used. Otherwise as specified in specification 83.34
- c) The pile driving shall be performed in series of 10 blows or as an alternative, continuously, but the driving resistance shall be observed and recorded for each series of 10 blows.
- x) Quantity shall be measured as number of series of 10 blows. Unit: pcs

83.3452 Supplementary driving to stop in soils

- a) Comprises supplementary driving to meet stop criteria in soils additional to the 300 blows covered by specification 83.342
- c) As in specification 83.342.
- x) Quantity shall be measured as number of series of 10 blows. Unit: pcs

83.3453 Supplementary chiselling in rock

- a) Comprises supplementary chiselling/final blows additional to the 300 blows covered by specification 83.344.
- c) As in specification 83.344.
- x) Quantity shall be measured as number of series of 10 blows. Unit: pcs

83.346 Redriving

- a) Comprises redriving of piles with up to 100 blows in series of 10 blows, see specifications 83.342 and 83.344. Levelling measurements of all piles after redriving are included in the specification. The specification also includes all costs for another or modified piling rig for redriving purposes.

Redriving in excess of 100 blows shall be included in specifications 83.3452 and 83.3453.

- b) Redriving shall be performed with the same hammer type as was used during the ordinary chiselling/final blows. Other types of hammers may be used in agreement with the Project Owner.
- c) Redriving shall be performed with a minimum of 5 series of 10 blows with a drop height as used in the final stages of the final driving/chiselling under specifications 83.342 and 83.344.

Redriving shall be terminated when the penetration per series for the last series of 10 blows is equal to or less than the specified stop criteria (soils) or the chiselling criteria (rock) as specified in specifications 83.342 and 83.344, and the pile has reached the same level it had when the first part of the driving procedure was completed. The penetration shall diminish or be constant.

If this requirement is not satisfied a further redriving/chiselling procedure shall be performed.

The level of each individual pile shall be measured immediately after redriving is completed. Unless otherwise agreed, documentation of pile positions shall be submitted to the Project Owner not later than 24 hours after redriving of a pile group has been completed. Later the level of each pile in the pile group shall be measured before the piles are cut.

Repeated redriving shall be performed if the Project Owner finds this necessary. The Project Owner may also decide if the extent of the redriving can be reduced if the results show that redriving does not seem necessary.

- x) Quantity shall be measured as number of series of 10 blows. Unit: pcs

83.35 Testing and inspection

- a) Comprises all materials, works and documentation related to testing and inspection activities not covered by specifications 83.3 - 83.346.

83.351 Dynamic control measurements (PDA etc.)

- a) Comprises all materials, works and documentation related to dynamic control measurements.
- b) Dynamic control measurements shall be performed on a number of piles as specified in *the special specifications* among the first piles that are driven when starting the piling operations. The object of the measurements is primarily to establish a corresponding data set for drop height, driving stresses, elastic deformations etc. for a given combination of pile driving equipment (hammer type)/pile type/ground conditions.

It is the responsibility of the contractor to employ the measurement data for performing further pile driving operations in an appropriate way regarding the above mentioned factors and other requirements. In general the measurements shall be planned and performed so that the contractor may utilize the results. The measurement programme shall be submitted to the Project Owner.

The measurements may also be used for evaluation of bearing capacity.

If substantial changes in pile driving equipment, pile type, ground conditions or other special requirements occur, supplementary dynamic control measurements shall be performed. This shall be decided by the Project Owner on the basis of existing experience with the pile diving operations.

- c) Dynamic control measurements shall in general be performed as described in the Code of Practice for Piles 2005 (Peleveiledningen 2005) chapter 13.3 if relevant.

Pile movement monitoring shall be performed on a representative sample of blow series during the dynamic control measurements and in such a way that a coherent set of data may be easily established between measurement results and pile movements.

Through the measurement programme the pile, if practically possible, shall be followed through the soil penetration and establishment of rock footing or stop criteria in soil with main focus on the final part of the pile driving. Measurements shall be performed for different stages in drop heights (driving energy) in order for coherent data sets to be established.

When not otherwise specified the measurement results shall be presented in a simple report containing as a minimum the following:

- pile identification
- type of driving equipment
- drop height (driving energy)
- driving stresses
- elastic deformations
- penetration
- estimated bearing capacity
- graph showing axial load versus time
- graph showing velocity versus time
- graph showing dynamic resistance versus permanent penetration

- x) Quantity shall be measured as number of performed measurement programmes. Unit: pcs

83.3511 Rigging for dynamic control measurements (PDA measurements)

- a) Comprises all (preliminary) rigging and (final) derigging of equipment for dynamic control measurements as well as travelling time for operators.

- x) Quantity shall be measured as number of performed measurement programmes. Unit: pcs

83.3512 Performance of dynamic control measurements (PDA measurements)

- a) Comprises all costs related to dynamic control measurements on a given pile, including mounting and demounting of sensors.

Reporting of measurement results shall be included in the specification.

- x) Quantity shall be measured as number of measured piles. Unit: pcs

83.352 Checking of curvature

- a) Comprises all materials and works as well as documentation in connection with curvature checking of completed piles.

- c) Curvature control shall be performed inside control ducts welded to the pile. Measurements shall be performed as described in *the special specifications*.

- x) Quantity shall be measured as number of measured piles. Unit: pcs

83.353 Loading tests

- a) Comprises all materials and works as well as documentation in connection with loading tests on completed steel piles.
- c) Loading tests shall be performed as described in *the special specifications*.
- x) Quantity shall be measured as number of load tested piles. Unit: pcs

83.36 Waiting time and operating time

- a) Comprises unforeseen waiting time caused by the Project Owner. Furthermore the specification comprises operating time that applies in connection with agreed extra work not covered by other specifications.
- x) Quantity shall be measured as waiting time certified by the Project Owner. Unit: hours.

83.361 Waiting time for piling rig for steel piles

- a) Comprises unforeseen waiting time caused by the Project Owner. Disruption of works that in the opinion of the contractor warrants waiting time shall be communicated to the Project Owner immediately.
- x) Quantity shall be measured as waiting time certified by the Project Owner, maximum 8 hours per day. Unit: hours.

83.362 Operating time for piling rig for steel piles

- a) Comprises all operating costs for pile driving rig with necessary operators. The specification applies in cases of agreed additional work and special conditions not covered by unit prices.
- x) Quantity shall be measured as operating time certified by the Project Owner. Unit: hour.

83.37 Completion works

- b) Completed (final) pile and pile driving logs including position measurements for all piles in a pile group shall be submitted to the Project Owner and the consent of the Project Owner shall be given before cutting of piles is performed and work on reinforcement installations and the casting process is initiated.

83.371 Cutting of steel piles

- a) Comprises cutting of steel piles.
- b) Cut surfaces shall be plane and at right angles to the longitudinal axis of the pile. Only cold cutting of piles is permitted.
- x) Quantity shall be measured as number of cut piles. Unit: pcs

83.4 Cast in place piles (bored piles and excavated piles)

- a) Comprises all deliveries and works resulting in a completed, bored pile, i.e. rigging, preparatory works, positioning of boring rig, slurry if applicable, penetration and excavation of drill pipe, loading and transportation of excavated material, rotating drill pipe into bedrock, chiselling, blasting if applicable and removal of debris from pile foot, reinforcement, casting and removal of drill pipe. The specification also covers any supplementary site investigations the contractor finds necessary, finding depth to rock at the location of the pile footing, rock coring if applicable and logging of pile after casting.

Also covers all deliveries and works for cast in place piles established by excavation instead of boring when specified in *the special specifications*. When the specification covers piles established by excavation, the following sub-specifications apply if relevant.

- b-c) See *the special specifications* regarding distance between neighbouring piles and requirements regarding sequence and time span between completion of one pile and penetration of steel pipe for the following pile.
- d) The pile head shall not deviate more than 100 mm from the design position in the horizontal plane unless otherwise stated in *the special specifications*.

When the cross-section deviates from a circular form, the maximum and minimum diameter shall be measured.
- e) The pile axis shall have a maximum deviation of 2% from the plumb line for vertical piles and a maximum deviation of 4% in any direction of the pile axis for batter piles unless otherwise stated in *the special specifications*.

Deviations horizontally and axially shall not be systematic for several piles.
- x) Quantity shall be measured as completed length of bored piles measured from the pile foot to the design pile head level. Cut-away parts and splices shall be included in the unit price. Unit: m

83.41 Preparatory and general works

83.411 Logs for cast in place piles

- a) Comprises recording of logs for each individual pile.

The pile logs shall at least contain the following:

- name of person in charge of the pile works
- name of foreman and the person responsible for recording logs
- identification of each pile and date of each production specification
- location of cables and service pipes
- supplementary site investigations
- supplementary drilling for bedrock location
- rock coring beneath pile footing
- diameter, thickness and length of drill pipe.
- recording of volume of removed material including depths and layer thicknesses
- penetration of hard layers
- level of bedrock for start and stop of chiselling
- check of finished pile footing, method and result
- water level in drill pipe
- density and viscosity of slurry
- amount of reinforcement, main reinforcement and stirrups
- dowels and anchoring bolts, dimensions and amounts
- concrete grade, mix design and retarding time
- measurements of air content and slump for fresh concrete
- time for starting and completing casting activities
- level of concrete surface in drill pipe and casting duct
- exact position of the pile, inclination and direction
- any deviation from the specified procedure during installation

The logs shall be available at the site at any time during pile production. A copy of the logs shall be submitted to the Project Owner not later than two days after the pile is cast unless otherwise stated in *the special specifications*.

The pile logs shall be duplicated and distributed as specified in *the special specifications* or as agreed with the Project Owner.

- x) Costs shall be given as a lump sum. Unit: LS

83.412 Location of cables and service pipes

- a) Comprises collection of information regarding cables and service pipes in the ground. All cables and service pipes that shall remain in service after pile installation shall be located and any conflicts with pile installation activities shall be determined on site. Separate specifications apply to relocation of cables and service pipes.

- x) Quantity shall be measured as number of bored piles. Unit: pcs

83.413 Excavations and backfilling

- a) Comprises removal of obstructions (building waste, rafts, blocks etc.) and backfilling with suitable materials before positioning of steel pipe for boring.
- b) The contractor may freely select materials for backfilling. The materials shall be suitable for the applied boring method.
- c) Specification 83.43 applies to transportation of excavated materials.

- x) Quantity shall be measured as planned volume of excavated material. Unit: m³

83.414 Supplementary site investigations

- a) Comprises supplementary site investigations providing the contractor with necessary information for planning and installation of bored piles.
- c) Site investigations shall be performed in accordance with Handbook 15 Field investigations. Results shall be reported on separate forms and attached to the pile logs.

- x) Costs shall be given as a lump sum. Unit: LS

83.415 Supplementary drilling for bedrock location

- a) Comprises drilling in order to locate the bedrock, see Handbook 015 Field investigations.

- c) Results shall be reported on separate forms and attached to the pile logs.

- x) Quantity shall be measured as number of drilled points. Unit: pcs

83.4151 Rigging and derigging of drilling equipment for bedrock location

- a) Comprises rigging and derigging of drilling equipment for bedrock location.

- x) Costs shall be given as a lump sum. Unit: LS

- 83.4152 Positioning of drill rig**
- a) Comprises positioning of drill rig at the drilling location as well as transfer between drilling locations at each pile location.
 - x) Quantity shall be measured as number of bored piles. Unit: pcs
- 83.4153 Drilling for bedrock location**
- a) Comprises drilling for bedrock location.
 - c) When drilling in firm soil or rock, the penetration depth and penetration rate per metre shall be recorded. The drill bit shall have penetrated at least 3 m into the bedrock before drilling is terminated.
 - x) Quantity shall be measured as drilled length. Unit: m
- 83.416 Rock coring for pile footing**
- a) Comprises rock coring for investigating rock quality below the pile footing, see Handbook 015 Field investigations.
 - x) Costs shall be given as a lump sum. Unit: LS
- 83.4161 Rigging and derigging for rock coring**
- a) Comprises rigging and derigging of equipment for rock coring.
 - c) The drilling equipment shall be able to obtain rock cores with minimum diameter 72 mm (diameter of borehole 86 mm).
 - x) Costs shall be given as a lump sum. Unit: LS
- 83.4162 Positioning of drill rig**
- a) Comprises positioning of coring drill rig at the drilling location as well as transfer between drilling locations for each planned pile
 - x) Quantity shall be measured as number of bored piles. Unit: pcs
- 83.4163 Coring and retrieval of cores from pile footing**
- a) Comprises coring and retrieval of cores in order to investigate the ground qualities where the pile footing is to be established.
 - c) Cores shall be stored in solid boxes. The boxes shall be clearly marked with pile number and borehole number and depth for each core. Core losses shall be marked with a wooden furring strip of corresponding length. Photographs shall be taken of boxes as soon as they are filled and before they are transported from the drill site.
 - x) Quantity shall be measured as total length of rock cores including core losses. Unit: m
- 83.42 Bored piles**
- 83.421 Rigging and derigging for bored piles**
- a) Comprises transportation, rigging and derigging of machinery and equipment for producing bored piles.
 - x) Costs shall be given as a lump sum. Unit: LS
- 83.422 Positioning and position control of bored piles**
- a) Comprises positioning of pile location before boring and position control after casting.
 - x) Quantity shall be measured as number of bored piles. Unit: pcs.
- 83.423 Positioning for boring**
- a) Comprises materials and preparation of a firm and even base for positioning of the boring rig as well as transfer between and repositioning of the boring rig for each pile. The specification also includes use of crushed stone aggregate if applicable. Handling of flushing water, ground water, drilling mud as well as all measures necessary in order to meet requirements regarding limitation of dust and noise shall also be included.
 - c) The base shall consist of stable materials in order for the pile to be produced within the tolerances specified in specification 83.4 e) unless otherwise specified in *the special specifications*.
 - x) Quantity shall be measured as number of bored piles. Unit: pcs
- 83.424 Installation of drill pipe and excavation of materials**
- a) Comprises penetration of drill pipe, emptying of encased materials, loading of excavated materials and transportation to temporary deposit dump if relevant, boring through hard layers if any, discharging of water if relevant and all necessary measures to prevent ground failure such as the use of water or slurry. Transportation of excavated materials away from the site shall be covered by specification 83.43.

- c) Piles shall be produced by equipment that rotates and/or pushes thick-walled drill pipes, fitted with hard metal bits at the end, into the ground. Penetration and emptying of the drill pipe shall take place without soil displacement or soil failure. If soil plugs form that have a tendency to be pushed down with the pipe, plugs shall be removed before penetration continues.

If soil conditions are such that soil failure (bottom heave) may occur in connection with emptying of the drill pipe, the following procedure shall be employed:

1. Emptying of pipe and chiselling of rock footing shall be performed in water-filled pipe.
2. Emptying of pipe and chiselling of rock footing shall be performed with slurry in the pipe.
3. The pipe shall be rotated to a depth of at least 0.1 m into the bedrock below the lowest rock level along the pipe perimeter before the pipe is emptied and chiselling is started.
4. If there is moraine or firm clay above the bedrock, the pipe shall be rotated into this layer and emptying may be initiated before contact with the bedrock is achieved.

The procedure to be followed shall be specified in *the special specifications*.

If indications of soil failure occur during emptying under water, the excavation shall be stopped immediately and backfilling performed with crushed rock aggregate if necessary. Excavation may be resumed when slurry has been introduced into the pipe or the pipe has been rotated into the bedrock or firm moraine.

If *the special specifications* permit excavation without special measures, preparations shall be made to quickly fill the pipe with water if a tendency to soil failure is observed or fines enter the pipe. The lowest part will normally have to be excavated below water unless the pipe is rotated sufficiently into the bedrock so that a watertight contact is achieved.

Due to the danger of soil entering the pipe, caution shall be observed when emptying the pipe in the transition zone near the bedrock. Mud shall only be removed by pumping when the pipe has been rotated into the bedrock, even at the lowest rock level.

- x) Quantity shall be measured as completed pile length measured from the centre point at the pile footing to the ground level. Unit: m

83.425 Rigging and derigging of equipment for use of slurry

- a) Comprises rigging and derigging of equipment for use of water or slurry in the casing.
- x) Costs shall be given as a lump sum. Unit: LS

83.426 Additional costs for use of slurry

- a) Comprises delivery of and filling of pipe with slurry as specified in *the special specifications* and removal and diversion of the slurry during casting operations.
- b) The slurry shall satisfy the requirements in NS-EN 1536, point 6.5.
- x) Quantity shall be measured as completed length of pile with the use of slurry in accordance with *the special specifications*. Unit: m

83.427 Stockpile of crushed rock

- a) Comprises all works and costs associated with having a sufficient stockpile of crushed rock available on site at all times in order to fill the pipe immediately in case soil failure
- x) Quantity shall be measured as volume of stockpiled crushed rock. Unit: m³

83.43 Transportation of excavated materials from shaft

- a) Comprises loading from temporary deposit dump, transportation and tipping/grading of excavated materials. Charges for tipping materials shall be included if applicable.
- x) Quantity shall be measured as planned volume of pile with diameter equal to the outer diameter of the drill pipe and length measured from the centre point at the pile footing to the ground level. Unit: m³

83.44 Pile footing

- a) Comprises penetration and rotation of drill pipe, chiselling, blasting and removal of debris from pipe and testing for the establishment of pile footing on firm ground/rock from the time when the pipe reaches the bedrock until casting operations can be performed. The specification also covers rigging and derigging as well as transfer and positioning of equipment and tools.
- c) The pile footing shall be horizontal and plane. The pile footing shall be established in firm ground/rock at a depth (D), see Figure 83.44-1. This depth shall as a minimum be 100 mm below the lowest level of firm ground/rock, determined as described in specification 83.415. The depth shall be increased depending on the inclination of the firm ground/rock surface and pile diameter (B) as specified in Table 83.4-1.

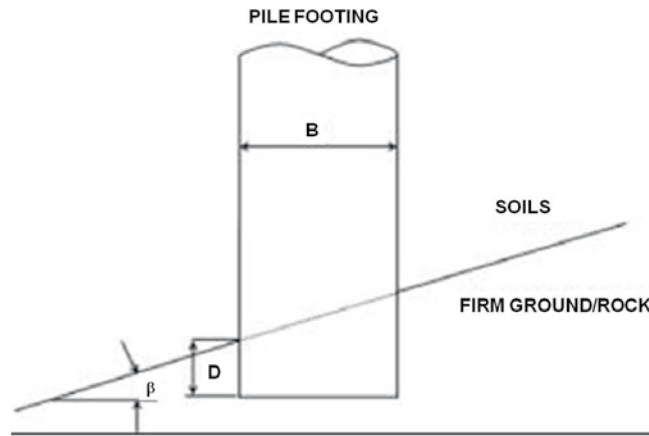

Figure 83.44-1

- e) Samples shall be taken from the bottom of each pile footing. The samples shall be marked and kept on the site. If rock types other than those expected in the area are encountered, this shall be reported to the Project Owner immediately and possible technical consequences shall be evaluated.

- x) Quantity shall be measured as number of piles. Unit: pcs

83.441 Rigging and derigging

- a) Comprises rigging and derigging of equipment and tools for establishing rock footings.

- x) Costs shall be given as a lump sum. Unit: LS

83.442 Positioning

- a) Comprises transfer and positioning of equipment and tools for establishing rock footings.

- x) Quantity shall be measured as number of piles. Unit: pcs

83.443 Establishing rock footings

- a) Comprises rotation of drill pipe in firm ground/rock from the point where the pipe periphery encounters rock or other approved firm layer until the whole pipe periphery is in contact with the firm layer/rock. The specification also covers all works to remove firm material/rock down to the level of the completed pile footing over the full cross-sectional area. These works may consist of drilling, blasting, chiselling or a combination as specified in *the special specifications*.

- c) When the slope of the bedrock is expected to be so great that it will be difficult for the drill pipe to get a grip on the rock for penetration by rotational action and removal of firm ground/rock, blasting may be used to establish the rock footing following a closer evaluation of the site conditions. Use of blasting techniques and procedures shall be submitted to the Project Owner.

- x) Piles are classified according to the slope of the firm layer/rock as presented in Table 83.4-1:

Table 83.4-1				
Specification	Group	Inclination of firm ground		Depth ratio
		Angle β degrees	Ratio, vertical: horizontal	D/B
83.4431	I	0	1 : ∞	0.10
83.4432	II	10	1 : 6.0	0.10
83.4433	III	20	1 : 3.0	0.10
83.4434	IV	30	1 : 1.7	0.15
83.4435	V	40	1 : 1.2	0.25
83.4436	VI	50	1 : 0.8	0.35
83.4437	VII	60	1 : 0.6	0.50
83.4438	VIII	70	1 : 0.4	0.65
83.4439	IX	80	1 : 0.2	0.90

Quantity shall be measured as number of piles for each slope group I-IX. Unit: pcs

83.444 Removal of debris from pile footing

- a) Comprises removal of all debris and mud from pile footing in firm layer/rock.
- c) Removal of debris from water-filled drill pipe shall be performed with an injector pump (mammoth pump) or equivalent. If an injector pump is utilised it shall be designed such that the whole pile footing area may be reached effectively. During pumping, the drill pipe shall be refilled with water in order to prevent ground water from entering the pipe.

Debris shall be removed from a pile footing by hand or by a correspondingly accurate method in a dry drill pipe.

- e) That the whole cross-sectional area has been cleaned shall be checked.

Checks of pile footings in water filled drill pipes shall be performed with a steel/aluminium rod that is dropped at a height of 0.2 m above the footing, or with a steel bar suspended by a wire. If mud or clayey gravel is suspected of being present at the bottom, a blunt object shall also be used since a rod has a tendency to penetrate soft soils.

If the check gives rise to suspicion that blocks or gouge exist below the pile footing, the Project Owner shall be notified and the footing reinspected, possibly by means of a video logger.

Footings in a dry drill pipe shall be checked by direct inspection.

- x) Quantity shall be measured as number of piles. Unit: pcs

83.445 Video inspection of pile footings

- a) Comprises all works with video inspection of pile footings, including submission of logings.
- x) Quantity shall be measured as number of video logings. Unit: pcs

83.45 Reinforcement and accessories in bored piles

- a) Comprises reinforcement, anchoring pipes and inspection ducts in piles as well as permanent (thin walled) outer formwork casings.

83.451 Reinforcement

- a) Comprises delivery and all works on complete reinforcement installed in drill pipe. Unless otherwise stated in *the special specifications*, the reinforcement shall consist of ribbed steel B 500 NC in accordance with NS 3576-3. Reinforcement spacers shall be made of concrete of a grade corresponding to the concrete used in the pile.
- b) The reinforcement shall have cover as specified in the design drawings. Unless otherwise stated, a minimum cover of 100 mm and nominal cover of 120 mm shall be used. The reinforcement shall satisfy the requirements in NS-EN 1536, point 8.2, but heating may not be used for bending. The reinforcement shall be bound as a cage with sufficient stiffness to prevent deformations during the casting process. The longitudinal reinforcement shall be kept in position by outside spiral bars or stirrups connected by welding at intersections.

In the lower part of the reinforcement a grate shall be constructed to reduce the risk of the reinforcement moving upward during the casting process. If the upper part of the reinforcement cannot be observed during the casting process, any movements of the reinforcement shall be monitored, for example by welding extension rods to one or more of the reinforcement bars.

- x) Quantity shall be measured as planned steel volume on the basis of bending schedules without additions for cut-off, waste, assembly bars etc. Unit: kg

83.452 Lap reinforcement

- a) Comprises drilling for, delivery of and grouting of lap reinforcement in completed, cut pile heads. Grouting of lap reinforcement shall be used when part of the pile is cut in order to remove inferior concrete on the pile head or where this is necessary in order to obtain sufficient length of protruding lap reinforcement. For lap lengths, diameter and length of lap reinforcement, see *the special specifications*.
- x) Quantity shall be measured as number of grouted lap reinforcement bars. Unit: pcs

83.453 Anchoring pipes/inspection ducts

- a) Comprises delivery and all works connected with anchoring pipes and inspection ducts fixed to the reinforcement cage.
- c) The pipes/ducts shall be welded or bound by steel wire to the reinforcement cage.
- x) Quantity shall be measured as the combined length of pipes/ducts. Unit: m

83.454 Thin walled formwork casings

- a) Comprises procurement and all works associated with installation of thin walled steel casings used as formwork inside the thick walled drill pipe before the latter is extracted.
- x) Quantity shall be measured as planned length of thin walled steel casings. Unit: m

83.46 Casting of bored piles

83.461 Casting of concrete in bored pipes

- a) Comprises delivery and casting of concrete, extraction of drill pipe as well as replenishment of concrete. Also covers topping with sand above the pile head if the pile is terminated below ground level, as well as removal of surplus or inferior concrete and cutting, chopping or chiselling of the pile head down to the correct level.

Works shall be performed according to inspection class 'Extended inspection' as specified in NS 3465.

- b) The concrete shall be in accordance with NS-EN 206-1, have a good workability and fulfil the requirements for concrete cast below water as described in Publication No. 5 from the Norwegian Concrete Association (Norsk Betongforening).

The concrete mix design including use of additives, consistency and casting method shall be adjusted to the pile production method and equipment.

The risks associated with this type of construction work shall be taken into account, e.g. the risk of outwash or layering, that the concrete may adhere to the drill pipe during extraction, that the reinforcement may lift etc.

The concrete mix design shall be submitted to the Project Owner before concrete casting is initiated.

- c) Casting operations shall be performed immediately after the pile footing has been cleaned and inspected and the reinforcement has been put in place. If casting is not started within 2 hours after the pile footing was cleaned and checked a new cleaning and inspection process shall be performed.

The water level in the drill pipe shall be kept at a level equal to or above the ground level during casting operations.

In cases where the pile extends through water or water bearing layers or layers of soft clay, the pile shall be cast inside a thin walled formwork casing installed inside the thick walled drill pipe and which is left in the ground when the drill pipe is extracted. See *the special specifications*.

Casting shall be performed as a submerged pipe procedure in accordance with Publication No. 5 from the Norwegian Concrete Association preferably with a concrete pump, alternatively with the Tremle metod. The casting pipe shall be securely fixed at the centre of the drill pipe. Casting shall proceed continuously and the casting pipe shall at any given time, when the drill pipe is/has been extracted, have a submerged depth of at least 1 m in wet concrete.

The drill pipe shall be extracted after casting is completed or in steps during the casting operations. During extraction of the drill pipe the mouth of the casting pipe shall always be at least 2 m higher than the bottom of the drill pipe, and it shall be monitored continuously to ensure that the movement of the concrete level in the drill pipe as a minimum corresponds to the volume of the extracted drill pipe. If the concrete or the reinforcement should move upwards during extraction of the drill pipe enabling surrounding soils to penetrate into the concrete, measures shall be initiated such as excavation of the wet concrete.

In order to secure high quality concrete at the pile head, casting shall be performed to a level at least 0.5 m above the theoretical top level. Excess concrete shall be removed by excavation when wet or chiselled away later. When piles are terminated more than 1 m below the ground level, sand or other suitable material shall be added at the top of the pile before extraction of the drill pipe is completed.

- x) Quantity shall be measured as length of completed piles measured from the centre of the pile footing to the planned pile head. Up to 10% concrete consumption in excess of the volume limited by the outer drill pipe diameter and length of pile shall be included. Concrete consumption in excess of 10% shall be covered through specification 83.462. Unit: m

83.462 Additional cost for excess consumption of concrete

- a) The specification applies if the concrete consumption exceeds 110% of the theoretical volume in accordance with specification 83.461.

- x) Quantity shall be measured at cast volume minus 110% of the theoretical volume. Unit: m³

83.47 Testing and inspection

- a) Comprises testing and inspection of completed, bored piles.

83.471 Coring of cast pile and in rock

- a) Comprises coring to inspect concrete in pile.

83.4711 Rigging and derigging for coring

- a) Comprises rigging, positioning and drilling of cores in pile concrete and rock.
- c) The drilling equipment shall be able to drill cores of diameter 72 mm (86 mm borehole diameter).
- x) Costs shall be given as a lump sum. Unit: LS

- 83.4712 Positioning of drill rig**
- a) Comprises positioning of drill rig for coring at each location as well as transfer between locations.
 - x) Quantity shall be measured as number of cored piles. Unit: pcs
- 83.4713 Coring and retrieval of cores in whole pile**
- a) Comprises drilling and retrieval of cores to check the quality of the concrete in piles.
 - c) Cores shall be stored in solid boxes. The boxes shall be clearly marked with pile number and borehole number and depth for each core. Core losses shall be marked with a wooden furring strip of corresponding length. Photographs shall be taken of boxes as soon as they are filled and before they are transported from the drill site.
 - x) Quantity shall be measured as total length of cores. Unit: m
- 83.4714 Coring and retrieval of cores from pile footing**
- a) Comprises drilling of cores for inspection of the transition zone between concrete and bedrock at the pile footing. Coring shall be performed through inspection ducts mounted in the reinforcement cage.
 - c) Cores shall be stored in solid boxes. The boxes shall be clearly marked with pile number and borehole number and depth for each core. Core losses shall be marked with a wooden furring strip of corresponding length. Photographs shall be taken of boxes as soon as they are filled and before they are transported from the drill site.
 - x) Quantity shall be measured as total length of cores. Unit: m
- 83.472 Non-destructive testing, logging of bored piles**
- a) Comprises logging of bored piles in order to detect cavities and deficiencies in cast piles. Logging shall be performed between inspection ducts installed in the reinforcement cage.
 - c) Logging may be performed with the following methods: gamma-gamma logging (GGL), crosshole sonic logging (CSL) or radar.
 - x) Quantity shall be measured as length of logged profile. Unit: m
- 83.473 Non-destructive testing and analysis of bored piles**
- a) Comprises excitation and analysis of reflected waves in bored piles in order to map cavities and deficiencies in cast piles. Excitation and monitoring of reflected waves shall be performed at the top of the pile.
 - c) Excitation and monitoring of reflected waves may be performed with the following methods: sonic echo (SE) testing or impulse response (IR) testing.
 - x) Quantity shall be measured as number of tested piles. Unit: pcs
- 83.48 Waiting time and operating time**
- 83.481 Waiting time for rig for bored piles**
- a) Comprises unforeseen waiting time caused by the Project Owner.
 - c) Reasonable expected waiting time due to testing, inspection and measurement activities performed by the Project Owner shall be included in the respective specifications.
 - x) Quantity shall be measured as logged waiting time, maximum 8 hours per day. Unit: hours.
- 83.482 Operating time for rig for bored piles**
- a) Comprises all costs for operating boring rig with necessary operators. The specification applies to agreed extra work and special conditions not covered by other specifications.
 - c) Rig operating time shall be certified by the Project Owner.
 - x) Quantity shall be measured as performed operating time. Unit: hour
- 83.5 Steel core piles**
- a) Comprises all deliveries and works with steel core piles resulting in completed and approved piles, i.e. preparatory and general works, rigging and positioning, drilling, grouting, delivery and installation of steel cores, testing and inspection.
- The specification also covers the risk of rejected piles, responsibility for all costs associated with production of replacement piles and all costs for supplementary site investigations and measures the contractor finds necessary in order to plan and perform installation of steel core piles, e.g. in order to avoid rejection of piles due to sloping bedrock. The contractor shall evaluate the risk of rejected piles and plan and carry out measures in order to prevent piles being rejected.
- 83.51 Preparatory and general works**

83.511 Pile logs for steel core piles

- a) Comprises all recording, reporting and distribution of pile logs with all required results.
- c) The pile logs shall at least contain the following:
- name of person in charge of the pile works
 - name of foreman and the person responsible for recording logs
 - pile number and date
 - drilling system
 - drill dimensions in soil and rock
 - depth of borehole and bottom level
 - flushing pressure/ water volume
 - irregularities during drilling
 - soil layering
 - description of soil/rock type
 - penetration rate in rock
 - result of borehole inspection
 - recording of water level
 - recording of water loss
 - grouting, grouting pressure and volume of grout and grout mix specifications
 - top level of casing
 - bottom level of casing
 - position of bottom of casing with deviations from planned position specified in mm
 - Inclination of top of casing with deviations from planned inclination specified in degrees
 - direction of inclination at top of casing with specification of deviation from planned direction. Deviations from planned direction shall be specified in relation to the pile axis.
 - straightness of casing
 - testing of steel quality and straightness of steel core elements
 - checking of the straightness and strength of splices on steel core piles
 - testing of grout. Grout mix design and volume of grout used and other test results shall be specified. Deviations from theoretical volume shall be specified.
 - monitoring of installation process for steel core piles. Any deviations shall be specified
 - monitoring of steel core pile driving. Hammer weight and penetration shall be specified
 - top level of steel core pile
 - length of steel core piles between splices
 - total length of steel core piles
 - bottom level of steel core piles
 - other relevant data for settling costs and evaluating pile condition and capacity
 - results of other test measurements as specified in *the special specifications*

All test data shall be presented on forms and in a condensed and easily readable way. The presentation form shall be submitted to the Project Owner in ample time before the works commence.

Test data for the different working operations for each pile group shall be submitted to the Project Owner not later than 48 hours after the works are completed or as specified in *the special specifications*.

- x) Costs shall be given as a combined lump sum for all logs for steel core piles. Unit: LS

83.512 Supplementary site investigations for steel core piles

- a) Comprises all costs related to the planning and performing of supplementary site investigations/locating bedrock and other efforts for investigating risks and preventing rejection of piles e.g. as a result of sloping bedrock. Logging of rock quality is also included. The need for and extent of investigations and/or actions shall be determined by the contractor in agreement with the Project Owner.
- b) Choice of drilling method and performance shall be in accordance with Handbook 015 Field investigations.
- x) Quantity shall be measured as number of drilled metres. Unit: m

83.52 Rigging and positioning for steel core piles

83.521 Rigging for steel core piles

- a) Comprises all transport, rigging and derigging of all equipment necessary for installation of steel core piles, like drilling, density control, pressure grouting, handling of drill mud, mounting and grouting of steel core as well as necessary support/working platform. Rigging plan with specification of loads shall be submitted to the Project Owner before the work commences.
- x) Costs shall be given as a lump sum. Unit: LS

83.522 Positioning for pile groups, drilling for steel core piles

- a) Comprises transfer, positioning and exact location of drill rig/tower as well as all costs associated with establishing a surveying basis for position measurements, or positioning of template and markings for exact positioning of piles.
- x) Quantity shall be measured as number of pile groups. Unit: pcs

83.523 Positioning for pile groups, installation of steel core piles

- a) Comprises transfer and positioning for mounting of steel core piles in addition to costs included in specification 83.522.
- x) Quantity shall be measured as number of pile groups. Unit: pcs

83.53 Drilling for steel core piles

83.531 Delivery and drilling of casings into soils

- a) Comprises delivery and installation of permanent casings including necessary drilling through soils and penetration of casing at least 0.5 m into solid rock. The specification also covers splicing and cutting of casing at the specified level as well as any surface treatment of the casing as specified in *the special specifications*.

Further penetration of the casing into solid rock is covered by specification 83.532.

- b) Casings shall be in accordance with the requirements in Table 83-1.

The inner diameter of casings shall be adjusted to the selected drilling system, the diameter of the steel core as well as requirements for spacers, see specification 83.551.

Wall thickness shall be selected on the basis of the drilling system, ground conditions, length of pile, load capacity and requirements regarding corrosion. Minimum wall thickness shall be 4 mm or as specified in *the special specifications*.

Casing elements shall be as long as possible and adjusted in order to keep the number of splices to a minimum. In general the length shall at least be 3 m.

For welding of casings see specification 85.24 and Table 83-2.

- c) In general a sequence shall be attempted for drilling and grouting so that the deepest piles in a pile group is installed first.

Casings shall be drilled through soil and into the bedrock. Casings shall be welded together in as long sections as possible. The lengths shall be adjusted so as to avoid halts in the drilling process in layers where the drill bit may stick/be blocked.

When casings are drilled through clay, silt and sand only flushing with water shall be used unless otherwise specified in *the special specifications*. Water pressure and quantities shall be adjusted in order to prevent erosion and high pore pressure in the ground.

When air powered down-the-hole hammers are used, the performance shall in general be such that the flow of exhaust air is directed downward as much as possible in order to prevent adverse effects on the surrounding soil formations. In soft soils only water shall be used to drive the casing.

Air and high pressure shall not normally be used to speed up the drilling process or quickly loosen up any blocking of drill bits when adding drill rods or splicing casings. Unnecessary drilling stops shall be avoided in order to prevent blocking of drill bits.

Unless otherwise specified in *the special specifications*, the type of drilling equipment shall be selected in accordance with the following specifications. This does not relieve the contractor of responsibility for the drilling being feasible with the selected equipment.

Under normal conditions, (e.g. medium strong to soft, not quick-clay etc.) a down-the-hole equipment with excentric bit may be satisfactory to use.

Under demanding conditions (e.g. fill deposits, hard and/or water-bearing moraine, great depths to bedrock etc.) and use of down-the-hole hammers a symmetrical drilling system with attached ring drill bit on the casing shall be preferred in order to prevent erosion. Symmetrical drilling systems shall be used for large diameter casings as well as for very steep rock slopes.

In quick clay or very soft clay or in combination with firm soils above bedrock it may be necessary to prevent materials, air or water entering the soil formation. This requires a system where the flushing fluid is returned to the surface inside the casing (reversible circulation system).

Minimum penetration of casings into rock shall be 0.5 m in solid rock or greater if specified in *the special specifications*.

When the casing has reached the final depth in solid rock a simple water level test (see specification 83.651) and water loss test (see specification 83.562) shall be performed as well as any pressure grouting and redrilling of hole in case of high water losses.

With the drilling process completed, the casing shall be driven to contact with the bedrock.

- d) The following tolerance requirements apply unless otherwise specified in *the special specifications*:
 - Position ± 100 mm in the horizontal plane.
 - Straightness, drilled casing/borehole in rock:

Maximum 0.2% change of direction over 2 m length if pipe, or minimum radius of curvature = 600 m over a length of 6 m. Continuous measurements shall be performed on casing and in boreholes in rock below the casing.

- Slope deviation:
Vertical piles: 1%
Batter piles: 2%
- Directional deviation:
Batter piles: 2% measured in any direction in relation to the theoretical pile axis.

In the case of deviations from one or more requirements, the Project Owner shall decide if the pile must be rejected.

- x) Quantity shall be measured as length of casings from the bottom level to the planned cut-off level. All cut-off parts and splices shall be included in the unit price. Unit: m

83.5311 Unspecified drilling system

- a) Comprises drilling with unspecified drilling system

83.5312 Eccentric drilling system

- a) Comprises drilling with eccentric drill bit

83.5313 Centric drilling system

- a) Comprises drilling with centric drilling system

83.5314 Reversible drilling system

- a) Comprises drilling with reversible drilling system

83.532 Drilling with casing in rock

- a) Comprises continued drilling with casing in solid rock in addition to the 0.5 m specified in specification 83.531, including delivery and splicing of casings if applicable. Any surface treatments shall also be included.

The specification also applies if it is considered on the construction site to be necessary and/or appropriate to drive casings to a greater depth than 0.5 m into solid rock. This shall be decided in agreement with the Project Owner.

Material requirements are specified in specification 83.531.

Drilling shall be performed to depths as specified in *the special specifications*.

- x) Quantity shall be measured as drilled distance in rock in excess of 0.5 m. Splicing shall be included in the unit price if applicable. Unit: m

83.533 Drilling below casing in rock

- a) Comprises continued drilling in rock without casing.
The specification also applies if it is considered on the construction site to be necessary and/or appropriate to drive piles to a greater depth than 0.5 m into solid rock without casing.
- b) Drilling in rock shall be performed with a rock drill bit after grouting has been carried out and the hole is made watertight.
- c) Drilling without casing shall be performed to depths as specified in *the special specifications*.
If necessary, guided drilling shall be performed in order to achieve sufficient straightness in the rock borehole.
- d) The drilling system shall be adjusted in order to achieve a minimum cover of 20 mm for steel core piles in rock or as specified in *the special specifications*.
- x) Quantities shall be measure as drilled length without casing in solid rock. Unit: m.

83.54 Grouting of borehole in rock

83.541 Grouting with up to 200 kg cement

- a) Comprises delivery of materials and all works associated with grouting of boreholes. A quantity of up to 200 kg of cement is included per grouting operation.
- c) Grouting of the bottom zone of a borehole shall be performed with mortar after the hole has been cleaned of soil particles and drilling mud with the aid of air or water as a flushing gas/fluid or by the use of an ejector pump. The grout mix shall be adjusted to the local conditions and the mix design shall be submitted to the Project Owner before the work commences.

Grouting shall be performed with packer positioned 0.5 m above the bottom of the casing. A grouting pressure of 1 bar higher than the pore pressure shall be applied. The grouting pressure shall be kept constant for 15 minutes. If no counterpressure is experienced, the consistency of the grout shall be made thicker or the use of other grouting materials shall be considered.

- x) Quantity shall be measured as number of completed grouting operations. Unit: pcs

83.542 Additional costs for consumption in excess of 200 kg cement

- a) Comprises consumption of cement in excess of 200 kg per grouting operation.
- x) Quantity shall be measured as quantity of cement in excess of 200 kg. Unit: kg

83.543 Redrilling of grouted mortar plug

- a) Comprises drilling through grouted mortar plug down to solid rock.
- c) Redrilling shall be performed after the grout has cured.
- x) Quantity shall be measured as number of redrilled holes. Unit: pcs

83.55 Installation of steel core piles

83.551 Delivery of steel core piles with splice included

- a) Comprises all deliveries of steel core piles including splices, cut-off parts and spacers.
- b-c) Steel core piles shall consist of standard steel in accordance with requirements specified in Table 83-1.

All delivered steel sections shall be marked in such a way that reference can be made to the delivery certificates. Steel mill markings that will disappear when work is performed on steel elements (cutting etc.) shall be transferred. Transferred markings shall be documented. Steel certificates shall be submitted at the latest one week before piles are installed and the certificate shall verify that the certificate and delivery are in agreement.

Piles shall be fitted with spacers that ensure central positioning of the piles in the casing. The spacers shall have a minimum height of 20 mm or greater if specified in *the special specifications*.

The spacers shall in general consist of electrically non-conductive materials with sufficient strength to resist stresses during the installation process (e.g. fibre-reinforced epoxy). The fixings of the steel core may be entirely or partly made of steel, but this steel shall not have contact with the casing.

Spacers shall be mounted with 3 units per cross-section and with a distance of 3 m between sections in the longitudinal direction of the pile. The spacers shall be designed in such a way that a smooth flow of grouting mortar is not obstructed.

The contractor is responsible for the detailed design of spacers so that all requirements regarding distance between steel core and casing for the completed steel core pile may be satisfied. Documentation regarding spacers shall be submitted to the Project Owner.

Piles shall be spliced in such a way that the spliced section has a satisfactory compression, tension and bending capacity with respect to potential stresses and, irrespective of loading, has a minimum tension and bending capacity equal to 60% of the capacity of the pile cross-section or as specified in *the special specifications*. Threaded or welded splices are permitted unless otherwise stated in *the special specifications*.

The strength properties of the splice shall be documented by the contractor through calculations and tests. Testing shall be performed to an extent sufficient to verify the calculation model and results.. Documentation from previous calculations/tests for an equivalent splice (identical with the same dimensions etc.) may be used if separate documentation is not required in *the special specifications*.

When splicing piles, the splicing element at the top of the pile shall have a full core length, minimum 6 m. Otherwise the distance between splices shall be minimum 3 m and the least number of splices shall be aimed for (as long core elements as possible).

Threaded splices shall have full contact with non-threaded parts and the same torque as specified in the splice documentation shall be applied when pulling the parts together. The pile shall not be subjected to any bending moments during splicing operations. Threaded splices shall be sufficiently fixed by point welding in order to prevent any unscrewing during the installation process.

For welding of piles see specification 85.24 and Table 83-2. Welded splices shall be performed as y-welds with sufficient depth around the pile periphery.

- d) Straightness requirements for steel core piles before installation shall be in accordance with NS-EN 10060. Directional changes at splices shall not be greater than 1:500.
- x) Quantity shall be measured as length of steel core pile from the bottom of the borehole in rock to the lower edge of the planned top plate. Unit: m

83.552 Extra costs for tension piles

- a) Comprises all additional deliveries for tension piles including preparation of steel surface in the anchoring zone.
- b) Tension piles shall have capacities as described in *the special specifications*.
- c) Tension piles shall be designed in such a way that adhesion is increased in the anchoring zone. The anchoring zone shall be flame cleaned and deposit welds or grooves shall be added without impairing the cross-sectional area more than 10%, or the anchoring zone shall be prepared as specified in *the special specifications*.

- x) Quantity shall be measured as length of prepared anchoring zone. Unit: m

83.553 Installation of steel core piles

- a) Comprises all deliveries and works for installation of steel core piles in approved casings and boreholes.

The specification also includes final cleaning of boreholes and casings before the steel core pile is installed as well as waiting time due to testing activities performed by the Project Owner prior to installation of the core. A waiting time of one hour is counted for testing of each pile. Necessary operators and cranes etc. as well as assistance in connection with testing activities performed by the Project Owner shall be included in the specification.

- b) Grouting mortar shall be suitable plant-mixed mortar or produced from cement, water and plasticising/stabilising/expanding additives, and possibly silica fume and/or super-plasticising additives. Ingredients shall satisfy NS-EN 206-1. The mortar shall have a water/cement ratio (mass ratio) equal to 0.40 or less. The mortar shall be mixed with a consistency which is soft enough to enable pumping down to the pile footing but stiff enough to have a resistance against wash-out in contact with water.

Densities of mortar samples taken from the mixing plant shall correspond to the theoretically calculated value ± 0.02 kg/litre. Densities of samples taken from excess mortar running over the rim of the casing when the last approximately 1 m of steel core is lowered into the casing shall not be more than 0.04 kg/litre less than the theoretically calculated value. Alternatively, correspondence with the specified w/c ratio may be demonstrated by direct measurements of the w/c ratio of mortar. The compressive strength of mortar samples taken from the rim of the casing and measured on cubes cured for 28 days shall not be less than 40 MPa.

For the mortar mix that is used, water separation of maximum 3% and volume changes maximum + 1.5/-0.0% shall be documented by testing according to Publication No. 14, annex V 1.4 "Wick-test" ("Veikettest") from the Norwegian Concrete Association. There is no requirement that tension rope or anything else shall be used as a wick, but the consistency of the mortar during the test shall be documented according to Annex V1.1 Funnel method (Traktmetoden) or V1.2 Spread time ("Utflyting på glassplate").

For splices performed during installation of steel core piles, the same requirements as specified in specification 83.551 apply.

- c) Before installation of steel core piles, the borehole and casing shall be emptied of all soil materials and drilling mud with the aid of air or water as a flushing gas/fluid. When an ejector pump is used to clean the borehole, a constant overpressure is required in the borehole (water filled casing) to prevent wash-out of soils above the bedrock. The use of ejector pumps shall be submitted to the Project Owner.

A plumb line shall be used to determine pile lengths exactly. The casing shall be cut to the specified level. If specified in *the special specifications* or ordered by the Project Owner, the straightness of the casing shall have been measured with a directionally oriented electronic inclinometer or borehole logging equipment.

Before the steel core is installed, a test pile with mounted spacers shall be used to control that the pile footing is satisfactory cleaned and that the pile can be installed to its full length without obstructions.

After the borehole has been inspected and approved, the hole shall be filled with grouting mortar. Boreholes in rock and the lower part of the casing shall be filled with water when the grouting mortar is pumped into the hole. Hoses or pipes for pumping the mortar shall be lowered down to the bottom of rock borehole and be designed in such a way that it is possible to verify that the end actually has reached the bottom of the hole. The amount of pumped grouting mortar shall as a minimum correspond to the theoretical volume plus 3 m of pile length. The mortar shall be pumped with an even and steady flow. The hose shall be kept at the bottom of the hole until all grouting mortar has been pumped and it shall be retracted before installation of the steel core pile.

If piles are installed at air temperatures below zero, the piles and the top part of the casing shall be heated and frost insulation shall be provided after the grouting mortar and the pile has been installed, see specification 83.556. Pile Installation is not permitted at temperatures below - 100 C.

When the piles are installed there shall be no corrosion on the pile surface. If necessary any corrosion shall be removed by steel brushing, sand blasting or torch cleaning. There shall be no grease on the pile surface and if necessary any grease shall be removed by degreasing agents. The piles shall also be free from soil particles or other adherents of any sort.

When installing the piles necessary consideration shall be given to the spacers so that they remain intact after the steel core has reached its full depth.

The piles shall be lowered into the hole and dropped for the last 1 m in free fall against the rock. Afterwards the pile is driven by an air powered hammer to verify that the pile is in contact with the rock. Choice of type of air powered hammer shall be submitted to the Project Owner.

The Project Owner shall be notified in writing in ample time (min. 24 hours) before installation of each pile core in order to be able to check that rock contact can be achieved.

- d) The following tolerance requirements apply unless otherwise specified in *the special specifications*:

- As in specification 83.531
- Deviations from planned top level of completed steel core pile: +50 mm

- e) The compressive strength of the mortar shall be checked once per 50 m of installed pile, but at least once per 3 piles on samples taken from mortar flowing over the rim of the casing just before the core is dropped in "free fall" and once per 100 m pile but at least twice per working shift on samples taken from the mixing plant. The mortar density at the mixing plant shall be checked when mixing is started and once per pile. The mortar density in the casing shall be checked once per pile. If density measurements with this testing frequency show satisfactory results the first two days of pile installation, the Project Owner may on request permit that the testing frequency be reduced from once per pile to once per working shift

Testing for documentation of water separation and volume stability shall be performed on site when installation of steel core piles starts. Alternatively, the Project Owner may accept documentation from another construction site where grouting mortar of exactly the same mix design is used provided that testing on this mortar has been performed within the last 6 months. If it is suspected that documentation from another site does not correspond to the mortar used, the Project Owner may require that new documentation testing be performed on site before the works can continue

- x) Quantity shall be measured as length from the rock footing to the planned top level of the steel core pile head. Unit: m

83.554 Cutting of steel core piles

- a) Comprises cutting of steel core piles to the specified level.
- c) Cores shall be cut by cold sawing and prepared in such a way that the pile head and pile bottom obtain satisfactory contact, at right angles to the longitudinal axis of the pile.
- d) Maximum permissible obliquity is $D = d:1\ 000$, where d = diameter of core in mm (see NS 3464 figure1 2b)
- x) Quantity shall be measured as number of cut piles. Unit: pcs

83.555 Delivery and mounting of pile head

- a) Comprises delivery of materials and all works with pile head, as well as all works in connection with mounting of pile heads on steel core piles.
- b-c) Steel grade requirements and welding shall be as for steel core piles, see specification 83.551.
- x) Quantity shall be measured as number of complete, mounted pile heads. Unit: pcs

83.5551 Head of compression pile

83.5552 Head of tension pile

83.556 Costs for installation of steel core piles in temperatures below zero

- a) Comprises all extra works, time, costs connected with installation of steel core piles in temperatures below zero.
- b) Installation and grouting of steel core piles in temperatures below -10 °C is not permitted.
- c) When temperatures are below zero the pile core and the top part of the casing shall be heated in order to prevent the grouting mortar from freezing before it is cured. After the pile has been installed and grouted the pile shall be insulated by winter mats or equivalent.
- x) Quantity shall be measured as number of piles. Unit: pcs

83.56 Testing and monitoring

83.561 Water level monitoring

- a) Comprises monitoring of water level in casings
- c) After the completion of drilling installation and cleaning of casings the casing shall be left filled with water for a minimum of 8 hours. Changes in the water level shall be recorded both if water flows over the top of the casing and if the level falls inside the casing.

The Project Owner shall decide if other minimum waiting times are appropriate and sufficient in order to have full control of water leakage in the ground and/or along the outside of casing.

Water level checks shall be repeated at later stages of the pile works if this is considered appropriate. This shall be decided in agreement with the Project Owner.

- x) Quantity shall be measured as number of piles. Unit: Pcs

83.562 Water loss measurements

- a) Comprises all materials and works in connection with water loss measurements including cleaning of borehole and casing before measurements are taken.
- c) Water loss measurements shall be performed to the extent specified in *the special specifications*, at least 2 piles picked at random from each pile group and always on tension piles.

The number of tested piles shall be increased if results from random tests are negative or this is considered necessary for structural or geotechnical reasons, including results from water level monitoring activities, see specification 83.561. The final extent of water loss measurements shall be decided by the Project Owner.

Water loss measurements shall be repeated at later stages of the pile works if this is considered necessary in order to obtain satisfactory pile quality. This shall be decided in agreement with the Project Owner.

Before water loss measurements are performed the borehole and casing shall be cleaned and emptied of all soil particles and drilling mud. When ejector pumps are used to clean the borehole, a constant overpressure is required in the borehole (water-filled casing) in order to prevent wash-out of soils above bedrock. The use of ejector pumps shall be submitted to the Project Owner.

When water loss measurements are performed, a packer shall be placed in the upper part of the casing as described in *the special specifications* and water pressure applied.

Unless otherwise stated in *the special specifications* the water pressure shall be 1 bar more than the pore pressure at the bottom of the casing. The water pressure shall be adjusted to the site conditions if appropriate. This shall be decided in agreement with the Project Owner. The water pressure shall be documented with a pressure gauge.

After a steady flow is obtained, the water loss shall be measured over a period of one minute.

Acceptance criteria: Water loss < 0.5 l per minute and metre borehole in rock for the specified water pressure.

If greater water losses are recorded, grouting shall be performed.

The results shall be submitted to the Project Owner after each measurement.

- x) Quantity shall be measured as number of water loss measurements performed. Unit: pcs

83.563 Measurement of casing straightness with template

- a) Comprises measurement of casing straightness with template.
- b) Measurements shall be performed as specified in *the special specifications* or in agreement with the Project Owner.
- x) Quantity shall be measured as length of measured casings. Unit: m

83.564 Measurement of casing straightness with instrument

- a) Comprises straightness measurements with a directionally oriented electronic inclinometer or equipment for borehole logging to the extent specified in *the special specifications* or as agreed with the Project Owner. Straightness measurements of any borehole in rock below the casing shall also be included in the specification.
- e) Requirements regarding measuring accuracy shall be specified in *the special specifications*.
- x) Quantity shall be measured as length of casings/boreholes measured. Unit: m

83.565 Testing of tension piles

- a) Comprises all deliveries and works in connection with tension testing of tension piles including equipment, rigging, performance and reporting of tension testing.
- c) The piles shall be tested in tension by measuring the extension of piles in 1/10 mm as specified in *the special specifications*.
- x) Quantity shall be measured as number of test loaded piles. Unit: pcs

83.57 Waiting time and operating time

83.571 Waiting time for rig for steel core piles

- a) Comprises unforeseen waiting time caused by the Project Owner. Normal waiting time associated with control activities before the core is installed is included in specification 83.561.
- x) Quantity shall be measured as unforeseen waiting time certified by the Project Owner. Unit: hour

83.572 Operating time for rig for steel core piles

- a) The specification applies in cases of agreed additional work and special conditions not covered by unit prices. The specification comprises all operating costs for pile rig with necessary operators
- x) Quantity shall be measured as operating time certified by the Project Owner. Unit: hour.

83.6 Sheet piles and bracing systems

- a) Comprises sheet piles and bracing systems in soils. Bracing systems for trenches are included in Main specification 4. Anchoring systems for sheet piles are included in specification 83.7.
- b-e) All works with sheet piles shall be performed in accordance with NS-EN 12063. In general all steel works shall be carried out in accordance with NS 3464 and all concrete works in accordance with NS 3465.

Steel sheet piles with bracings, cushions and foot bolts etc. shall be in accordance with requirements in Table 83-1. Different steel grades may be used if specified in *the special specifications*, or in agreement with the Project Owner. The steel shall be marked in such a way that reference can be made to the delivery certificates.

Sheet piles or bracings made of wood shall as a minimum meet the requirements for class C24 according to NS-EN 338.

Testing of concrete and mortar shall be performed according to NS-EN 12390.

Safe job analyses (SJA) shall be performed for all work specifications that may cause injuries to people or equipment. All health, environment and safety (HES) requirements imposed by the authorities shall be satisfied.

- x) Quantity shall be measured as completed areas of sheet pile wall. Heights shall be measured from bedrock or a specified depth limit to the top of the planned sheet pile. Length shall be measured along the planned centreline of the sheet pile wall. Unit: m²

83.61 Steel sheet piles

- a) Comprises all deliveries and works up to driven and completed steel sheet pile wall including rock footing if applicable and also removal of steel sheet pile wall if relevant. Preparation of sheet pile wall plans and driving plans as well as any noise reducing measures shall also be included.

Internal bracings and sheet pile bracings shall be included in specification 83.65 and cushions shall be included in specification 83.66.

- b) Materials shall not be damaged or have defects. Materials that will be incorporated as a permanent structural part of the construction shall be unused unless otherwise stated in *the special specifications*.

Used materials may be employed when they satisfy necessary functional requirements and they are not incorporated as part of the finished structure.

Materials shall be transported, handled and stored in such a way that the quality of the finished product is not impaired. They shall furthermore be stored and marked in such a way that no confusion or mixing of different material types and grades can occur.

In areas where it is important with respect to the surroundings that the groundwater level is not lowered, attempts shall be made to make the sheet pile wall watertight.

Z-profiles shall be used for permanent sheet pile walls.. For temporary sheet pile walls, u-profiles may be used. Section modulus requirements shall then be increased by 20%

- c) The contractor shall prepare plans for temporary sheet pile walls with specifications regarding sheet pile dimensions, rock footings, bracings, driving method and corresponding excavation plan unless otherwise specified in *the special specifications*.

Technical calculations and plans shall be submitted to the Project Owner before work commences.

Pile driving logs shall be recorded for sheet piles and for preparation of rock footings if applicable, see specification 83.6111.

If necessary the pile locks shall be filled with bitumen, grease or similar sealing materials before driving, in order to obtain sufficient sealing effects. Requirements regarding sealing of locks shall be specified in *the special specifications*.

Splicing of sheet piles shall be performed in such a way that the structural capacity of the sheet pile wall is not reduced. Splices at the same level and continuous through several needles shall not be permitted. Splicing of permanent steel piles shall not be permitted.

The sheet piles may be driven by hydraulic rams, vibro hammers, or drop hammers according to the contractor's own operational needs. All costs associated with the change of driving equipment shall be included in the unit price.

Works related to strengthening of the top of sheet piles for driving purposes shall be included in the unit price.

Driving of sheet piles shall be performed in a prudent manner and according to the driving plan. Driving shall if possible be performed with blows that are centred in relation to the section profile. All sheet piles shall be interlocked.

In order to fulfil the requirements related to the completed supporting structure, excess spacing may be allowed. The sheet pile wall shall then be positioned outside the theoretical sheet pile line in order to compensate for any inward movements during excavation.

The excess spacing may be determined on the basis of the soil type, depth of excavation and bracing method.

Driving shall be performed according to one of the following methods:

Each sheet pile shall be driven to its final depth in one operation. This method is only allowed in soils with low driving resistance, when driving to small depths and for short walls.

Driving to full depth shall be performed in successive steps. A wall section shall be established over a certain length and driving shall be performed by repeated driving of each needle along the section until the full depth is reached.

Sheet piles shall be driven in such a way that needles do not alter inclination in the direction of driving. If necessary, solid guides shall be employed, and the whole wall shall be driven successively in repeated steps.

For driving with drop hammers, hammer weights within ranges as specified in Table 83.6-1 are recommended. Vibro hammers with less than 300 blows per minute should have a weight 20% to 30% of that of the driven unit.

Sheet pile/mass kg/m		Hammer weight as a % of the weight of the driven unit
above	up to and incl.	
0	100	200
100	200	150
200		100

The drop height shall be reduced immediately when the bedrock is reached.

When driving with follower, sufficient guidance shall be provided for the sheet pile.

When installation by flushing is used, it shall be performed in such a way that no other structural components in the vicinity, in particular already installed piles or sheet piles, are under-washed, loosen or in other ways have their bearing capacity impaired. Inclined sheet piles that are flushed shall not have a less steep inclination than planned when the installation is completed.

Sheet piles that are damaged during driving shall be replaced or repaired in order to fulfil their intended use. The same applies in the event of leaks in the sheet pile wall or large deviations from the intended position or driving depths.

Excavations in front of the sheet piles or other loading of the sheet pile wall shall not be allowed before the driving logs or other documentation submitted to the Project Owner have verified that rock footings have been produced in accordance with the requirements.

Excavated material or similar shall not be placed behind and closer to the retaining wall than 0.5 m when work is performed below the wall. Regarding restrictions on loads behind the retaining wall, see *the special specifications*.

Where work is performed downhill from sheet pile walls, the wall shall protrude at least 0.15 m above the upper surface or ground level behind the wall if no other safety arrangements are made.

When permissible noise levels are specified in *the special specifications* necessary precautions shall be taken in order to meet the requirements.

- x) Quantity shall be measured as completed area of sheet pile wall. Heights shall be measured from bedrock or given depth limit to the planned top of the sheet pile. Length shall be measured along the planned centreline of the sheet pile wall. Unit: m².

83.611 Preparatory and general works

83.6111 Logs for steel sheet piles

- a) Comprises all deliveries and works resulting in completed, submitted and approved logs for sheet piling works in accordance with NS-EN 12063, item 10.

The logs shall contain sufficient information for identification of:

- working site,
- date of works
- working method and equipment
- length and level of sheet pile and pile type
- length and level of footing bolts and type of bolt

- information regarding drilling results for installation of dowels in rock
- criteria for chiselling of rock footings
- greasing of locks before driving; type of sealant and application method.
- splicing, method and level for each needle for temporary sheet piles

- b-c) The logs shall be duplicated and distributed as specified in *the special specifications*. Unless otherwise specified the logs shall be submitted at the latest 48 hours after the sheet pile wall has been driven and thereafter 48 hours after footings are anchored in rock if applicable.

Logs shall be dated and signed by the foreman in charge of the piling operations and the person responsible for recording logs.

- x) Costs shall be given as a lump sum. Unit: LS

83.6112 Site investigations before driving of steel sheet piles

- a) Comprises all deliveries and works resulting in a completed site investigations report in accordance with Handbook 015 Field investigations. The extent and type of investigations shall be in accordance with *the special specifications*.

- x) Costs shall be given as a lump sum. Unit: LS

83.6113 Excavation and backfilling along pile line for driving of steel sheet piles

- a) Comprises excavation along the piling line down to soils that may be penetrated by sheet piles. The specification also covers backfilling and compaction of materials that may easily be compacted and penetrated.

- b-c) Maximum excavation depths and any requirements for stepwise excavation in sections shall be specified in *the special specifications*.

- x) Quantity shall be measured as linear metres of trench. Unit: m.

83.612 Rigging and positioning

83.6121 Rigging for steel sheet pile works above water

- a) Comprises transportation, rigging and derigging of necessary machinery and equipment for installation of steel sheet piles positioned and driven above the groundwater level or in a drained construction pit, see specification 81 a). Also covers equipment and special precautions against noise and vibrations if this is required in *the special specifications*. Temporary construction roads are included in specification 13.1.

- x) Costs shall be given as a lump sum. Unit: LS

83.6122 Positioning for driving of steel sheet piles above water

- a) Comprises positioning, transfer and exact positioning of piling rig/tower as well as all costs connected with establishing a surveying basis for exact positioning of steel sheet piles to be positioned and driven above the groundwater level or in a drained construction pit, see specification 81 a).

- x) Costs shall be given per continuous sheet pile wall. Unit: pcs

83.6123 Rigging for steel sheet pile works below water

- a) Comprises transportation, rigging and derigging of necessary machinery and equipment for installation of steel sheet piles positioned at or below the groundwater level, see specification 81 a). Also covers equipment and special precautions against noise and vibrations if this is required in *the special specifications*. Temporary construction roads are covered in specification 13.1.

- x) Costs shall be given as a lump sum. Unit: LS

83.6124 Positioning for driving of steel sheet piles below water

- a) Comprises positioning, transfer and exact positioning of piling rig/tower as well as all costs connected with establishing a surveying basis for exact positioning of steel sheet piles to be positioned at or below the groundwater level, see specification 81 a).

- x) Costs shall be given per continuous sheet pile wall. Unit: pcs

83.613 Delivery and driving of steel sheet piles

- a) Comprises all deliveries and works resulting in completed, driven and if applicable cut, sheet piles not covered by specification 83.611, 83.612.

- d) Unless otherwise stated in *the special specifications* the following tolerance criteria shall apply to sheet pile works and resulting deformations:

Maximum permissible deviation for top of retaining wall: ± 100 mm. Maximum permissible deviation from the plumb line for vertical sheet piles: $\pm 2\%$. Maximum permissible deviation from the design inclination for inclined sheet piles: $\pm 5\%$.

Requirements regarding deviations for vertical and inclined sheet piles shall be satisfied by measuring from the pile top to any arbitrarily chosen point on the sheet pile.

- x) As in process 83.61. Unit: m²

- 83.6131 Delivery of steel sheet piles**
- a) Comprises procurement, transport and storage of sheet piles.
 - x) As in specification 83.61. Unit: m²
- 83.6132 Welding of steel ducts onto steel sheet piles**
- a) Comprises delivery, cutting and welding of steel ducts to the sheet piles for deformation measurements or installation of dowels as well as strengthening and plugging of the bottom end of the ducts in order to prevent damage to the ducts during driving.
 - b-c) Regarding steel grade, dimensions and strengthening of ducts as well as working procedures see *the special specifications*.
 - x) Quantity shall be measured as completed length of welded steel ducts. Unit: m
- 83.6133 Driving of steel sheet piles**
- a) Comprises driving, if necessary splicing, and where applicable sealing of sheet piles against water leakage.
 - x) As in specification 83.61. Unit: m²
- 83.6134 Additional driving through hard layers**
- a) Comprises driving of sheet piles through hard layers as specified in *the special specifications* in addition to specification 83.6133.
 - c) If the penetration is less than specified in *the special specifications* without rock contact, the Project Owner shall be notified.

When using drop hammers the pile penetration shall be measured for each series of 10 blows with a drop height of 0.25 m. When using vibro hammers the pile penetration shall be measured periodically. Driving procedures shall be specified in *the special specifications*.
 - x) Quantity shall be measured as length of vertical driving per sheet pile with penetration less than specified in *the special specifications*. Unit: m
- 83.614 Rock footing for steel sheet piles**
- a) Comprises all materials and works in connection with establishing rock footings for steel sheet piles such as mounting of pile shoes by welding and mounting of foot bolts/dowels. Also covers all works in connection with bevelled cuts and strengthening of the lower end of sheet piles and supplementary sealing of sheet piles if leakage occurs between pile and bedrock.
 - x) Quantity shall be measured as length of contact contour against the bedrock as a horizontal projection along the sheet pile centreline. Unit: m
- 83.6141 Rock footing with bolts/dowels**
- a) Comprises predrilling of boreholes to the prescribed depth in rock, delivery of bolts and grouting mortar, all works in connection with installation of bolts and bevelled cutting of sheet piles if applicable.

Logs shall be submitted that indicate the opening between the bottom of a sheet pile and the bedrock for each bolt as well as measured distance from the top of the sheet pile to the top of installed bolt.

Logs shall be submitted at the latest 48 hours after drilling for each bolt has been performed or as specified in *the special specifications*.
 - b-e) For qualities, dimensions and installation of bolts, see *the special specifications*.

The grouting mortar shall be cement-based and have a w/c ratio = 0.4 or less. The mortar mix design and use of additives shall be submitted to the Project Owner.

Installation of dowels shall be performed from ground level. The bolts shall be inserted in predrilled boreholes in rock through ducts welded to the sheet pile and fixed to the rock by grouting. A grouting hose shall be lowered into the bottom of the borehole and grouting shall be performed from the bottom of the hole. Unless otherwise stated the bolt shall extend at least 1 m into the bedrock and at least 1 m up along the sheet pile. Bolts shall be inserted in a controlled manner into the rock and the distances from the top of the sheet pile to the top of each bolt shall be recorded to ensure that bolts are positioned correctly.

Any openings between the bottom of sheet piles and the bedrock shall be measured with an accuracy of ±20 mm. The Project Owner shall be notified before bolts are installed if openings are larger than what is specified in *the special specifications*.
 - x) Quantity shall be measured as number of bolts. Unit: pcs.
- 83.6142 Rock footings for sheet piles with welded pile shoes**
- a) Comprises delivery and welding of pile shoes on sheet piles, bevelled cutting and reinforcement of pile end as well as chiselling of rock footing.

Pile shoes shall be welded to pre-cut slits in the pile web of each pile section. The pile shall be reinforced near the shoe with plate stiffeners. The pile end shall otherwise have bevelled cuts on each side of the shoe. The shoe shall be formed as a normal pile shoe either by hollow lathe cutting and hardening or by adding a hard welded rim.

When the sheet pile has reached rock, driving shall be performed in series of 10 blows with a drop height of 0.1 to 0.25 m. Drop hammers shall be used and penetration measured for each blow series.

Driving procedures/stop criteria and chiselled depth shall be as specified in *the special specifications*.

Logs documenting that the rock criterion has been achieved for each pile shoe shall be submitted at the latest 48 hours after the sheet pile has been driven to stop or to criteria specified in *the special specifications*.

- x) Quantity shall be measured as number of pile shoes. Unit: pcs.

83.6143 Chiselling of rock footing for steel sheet piles

- a) Comprises chiselling of rock footing for sheet piles.

- c) When the sheet pile has reached rock, driving shall be performed in series of 10 blows with a drop height of 0.1 to 0.25 m. Drop hammers shall be used and penetration measured for each blow series.

Driving procedures/stop criteria and chiselled depth shall be as specified in *the special specifications*

Logs documenting that the rock criterion has been achieved for each pile shoe shall be submitted at the latest 48 hours after the sheet pile has been driven to stop or to criteria specified in *the special specifications*.

- x) Quantity shall be measured as number of single sheet piles with chiselled rock footing. Unit: pcs

83.615 Reinforcement and finishing works for steel sheet piles

- a) Comprises reinforcement of sheet piles and finishing works for sheet piles as specified in *the special specifications*.

- b-c) For qualities, dimensions and execution see *the special specifications*.

- x) As in specification 83.61. Unit: m²

83.6151 Welding of sheet pile locks

- a) Comprises welding of sheet pile locks as specified in *the special specifications*.

- b-c) Regarding qualities, dimensions and execution see *the special specifications*.

- x) Quantity shall be measured as length of welded sheet pile locks. Unit: m

83.6152 Reinforcement of sheet pile foot

- a) Comprises reinforcement of sheet piles as specified in *the special specifications*.

- b-c) For qualities, dimensions and execution see *the special specifications*.

- x) As in specification 83.61. Unit: m²

83.6153 Reinforcement of middle part of steel sheet pile

- a) Comprises reinforcement of sheet piles as specified in *the special specifications*.

- b-c) For qualities, dimensions and execution see *the special specifications*.

- x) As in specification 83.61. Unit: m²

83.6154 Frost insulation of steel sheet piles

- a) Comprises frost insulation of sheet piles as specified in *the special specifications*.

- x) As in specification 83.61. Unit: m²

83.6155 Corrosion protection of steel sheet piles

- a) Comprises corrosion protection of sheet piles as specified in *the special specifications*.

- x) As in specification 83.61. Unit: m²

83.6156 Sealing of sheet piles

- a) Comprises special sealing works for sheet piles, pile locks, pile footings and anchorings through pile wall or other conditions specified in *the special specifications*.

- x) Costs shall be given as a lump sum. Unit: LS

83.616 Control and documentation

- a) Comprises control and documentation of sheet piles as specified in *the special specifications*.
- x) Costs shall be given as a lump sum. Unit: LS

83.6161 Special inspection activities for sheet piles

- a) Comprises extended inspections over and above the normal level of inspection with recording of logs for sheet piles. The extended inspection shall be performed as specified in *the special specifications*.

Lack of follow-up of an extended inspection may lead to halts in sheet pile work. Such halts shall not qualify for paid waiting time unless they occur for reasons for which the Project Owner is responsible.

Any dependence of operations on inspections shall be clearly specified in *the special specifications*.

- x) Costs shall be given as a lump sum. Unit: LS

83.6162 Documentation of sheet piles remaining in the ground

- a) Comprises documentation of sheet piles that will remain in the ground according to *the special specifications*.

The documentation shall as a minimum include:

As-constructed drawings showing the location of remaining sheet piles on plan projections and on vertical sections as well as the final cut-off level. Restrictions on later works in the vicinity of the sheet piles shall be shown on the drawings.

- x) Costs shall be given as a lump sum. Unit: LS

83.617 Waiting time and operating time

- a) Comprises unforeseen waiting time caused by the Project Owner. The specification also covers operating time in connection with agreed extra work.

- x) Quantity shall be measured as used time certified by the Project Owner. Unit: hour

83.6171 Waiting time for rig for steel sheet piles

- a) Comprises unforeseen waiting time caused by the Project Owner. Disruption of works that in the opinion of the contractor warrants waiting time shall be communicated to the Project Owner immediately.

- x) Quantity shall be measured as waiting time certified by the Project Owner, maximum 8 hours per day.
Unit: hour

83.6172 Operating time for rig for steel sheet piles

- a) The specification becomes applicable in the event of agreed extra work or special conditions not covered by unit prices. Includes costs for operation of the rig with necessary operators

- x) Quantity shall be measured as used operating time certified by the Project Owner. Unit: hour

83.618 Extraction and removal of steel sheet piles

- a) Comprises removal of temporary sheet pile walls.

- c) Temporary sheet pile walls shall be removed completely or to the extent *the special specifications* specifies when the functioning time ends, if the removal can be performed without any risk of damage.

Removal of sheet pile walls shall only be initiated when the structure can take on the loads it is designed for.

Measures shall be taken to prevent any harmful slides, settlements etc in connection with the extraction of sheet piles.

Cavities that will result from extraction of retaining walls and bracings shall be refilled according to *the special specifications*.

Extraction of sheet piles shall be performed in such a way that the structure, nearby buildings, cables and service pipes or other installations will not be damaged or subjected to danger.

- x) Quantity shall be measured as area of extracted sheet piles measured from the bottom of the sheet piles to the ground level. Unit: m²

83.6181 Rigging for extraction of sheet piles above water

- a) Comprises transportation, rigging and derigging of machines and equipment necessary for extracting or demolishing and removing sheet piles which are required to be driven with the starting point above the groundwater level or in a drained construction pit, see specification 81, a). Also covers equipment and special precautions against noise and vibrations if required in *the special specifications*.

- x) Costs shall be given as a lump sum. Unit: LS

83.6182 Rigging for extraction of sheet piles below water

- a) Comprises transportation, rigging and derigging of machines and equipment necessary for extracting or demolishing and removing sheet piles which are driven with the starting point below the ground-water level, see specification 81, clause a). Also covers equipment and special precautions against noise and vibrations if required in *the special specifications*.
- x) Costs shall be given as a lump sum. Unit: LS

83.6183 Extraction and repurchase of sheet piles

- a) Comprises all works connected with extracting or demolishing and removing temporary sheet pile walls. The contractor shall take over all extracted sheet piles and accessories.
- c-x) As in specification 83.61. Unit: m²

83.6184 Cutting of sheet piles

- a) Comprises cutting of sheet piles at the specified level. The contractor shall take over all cut-off parts and other materials.
- d) The cutting accuracy shall be ± 100 mm or as specified in *the special specifications*.
- x) Quantity shall be measured as length of cutting line along the planned centreline of the sheet pile wall. Unit: m

83.62 Wooden sheet piles

- a) Comprises completed, installed wooden sheet piles as specified in *the special specifications* as well as later removal of the wooden sheet piles. Internal bracings and braced sheet piles shall be covered by specification 83.65 and cushions for sheet piles shall be covered by specification 83.66.
- b-c) Wooden sheet pile walls shall be constructed of tongue-and-groove boards of with a minimum thickness of 45 mm. Wooden materials employed for sheet piles shall as a minimum satisfy the requirements for class C24 according to NS-EN 338.

Contact between tongue and groove shall be ensured by a bevelled cut at the bottom before driving. The top of the wooden sheet pile shall be protected by the use of a tension ring or helmet.

Wooden sheet piles shall be driven with the groove in the direction of the driving operations. If relevant a wooden gusset may be inserted into the groove in order to prevent soil or rocks from entering the groove.

When driving with a follower, special care shall be taken to achieve proper guidance and satisfactory contact between tongue and groove.

See also NS-EN 12063: 1999, Appendix F.

- x) Quantity shall be measured as completed area of wooden sheet pile wall. The height shall be measured from rock or planned bottom level to the top of the sheet piles. Length shall be measured along the planned centreline of wooden sheet piles. Unit: m²

83.63 Stop logs (Berliner-Wand)

- a) Comprises completed retaining wall made of stop logs as specified in *the special specifications* as well as later removal of the stop logs.

Internal bracings and shorings shall be included in specification 83.65 and cushions shall be included in specification 83.66.

- b) The materials used shall have properties and dimensions as specified in *the special specifications*. Wooden materials used for bracing or shoring shall as a minimum satisfy the requirements for class 24 according to NS-EN 338. Retaining walls with stop logs shall be constructed as specified in *the special specifications*. Logs shall be positioned between girders continuously as excavation proceeds and fast enough to prevent soil slides. Necessary adjustments and sealing measures shall be implemented near the bedrock.
- x) Quantity shall be measured as completed area of stop logs. The height shall be measured from the bottom of the lowest log to the top of the topmost log. Length shall be measured along the planned centreline of the stop log retaining wall. Unit: m²

83.64 Other types of retaining walls

- a) Comprises other types of retaining walls not covered by specifications 83.61, 83.62, or 83.63. See *the special specifications*. Internal shoring and bracing of retaining walls shall be covered by specification 83.65 and cushions for retaining walls shall be covered by specification 83.66.
- x) As in specification 83.6. Unit: m²

83.65 Internal bracings and shoring of sheet pile/retaining walls

- a) Comprises complete arrangements of internal bracing and shoring of sheet piles and other types of retaining walls as specified in the construction plan or *the special specifications*. Cushions for sheet piles/retaining walls shall be covered by specification 83.66.

The specification also includes demolition and removal of bracing and shorings when they are no longer needed.

- b-c) Bracing shall be carried out in such a way that work on the construction site is not unnecessarily hampered. See also *the special specifications*.

Wooden materials used for bracing purposes shall as a minimum satisfy the requirements for class 24 according to NS-EN 338.

Plans for temporary sheet pile walls with specification of material properties, dimensions, details and positioning of bracing systems with appurtenant excavation plan shall be prepared by the contractor, unless otherwise specified in *the special specifications*.

Tension members/bracings shall be fixed to cushions or sheet pile walls by tension joints. The cushions shall also be fixed by tension joints to the sheet pile wall. Calculations and plans shall be submitted to the Project Owner before work commences.

- d) Bracings shall be positioned with an accuracy of ± 50 mm in relation to the specified position.
x) Quantity shall be measured as planned length of bracings. Unit: m

83.66 Cushions for anchored and internally braced sheet piles/retaining walls

- a) Comprises complete establishment of cushions etc. for anchoring and bracing of sheet piles and other retaining walls as specified in the construction plan or in *the special specifications*. Internal bracings for sheet pile/retaining walls shall be covered by specification 83.65. Anchorings shall be covered by specification 83.7.

The specification also includes demolition and removal of cushions when they are no longer in use.

- b-c) Wooden materials used as cushions shall as a minimum satisfy the requirements for class C24 according to NS-EN 338.

Plans for temporary sheet pile walls, with specification of material qualities, dimensions, details and positioning of bracing systems with corresponding excavation plan, shall be prepared by the contractor, unless otherwise specified in *the special specifications*.

For bracing members in tension the cushions shall be fixed by tension joints to the sheet pile wall. Calculations and plans shall be submitted to the Project Owner before work commences.

See also *the special specifications*.

Cushions shall be positioned with an accuracy of $+50 / -0$ mm in relation to the specified position.

- x) Quantity shall be measured as length of cushions. Unit: m

83.7 Anchorings and bolts in rock and soils for structures

- a) Comprises all works and costs in connection with delivery and construction of complete and accepted temporary or permanent anchorings in rock or soils, with or without pre tensioning. Also covers bolts in exposed rock if applicable. Dowels for sheet piles are specified in specification 83.614. Necessary sealing of soils and rock in order to perform the work in a satisfactory way shall also be covered by the specification. Also includes preparation of logs for anchorings as well as any drawings and work descriptions in accordance with *the special specifications*.

Safe job analyses (SJA) shall be performed for all operations that may harm personnel or equipment. Examples of such operations are drilling, injection grouting and tensioning.

- b-e) All anchoring work shall be performed in accordance with NS-EN 1537.

In general all steel works shall be performed in accordance with NS 3464. Testing of injection grout and grouting mortar shall be performed in accordance with NS-EN 445. For permanent tension anchors, test samples shall be taken of the grouting mortar overflowing over the top of the casing.

Steel used for permanent anchorings and bolts shall have corrosion certificate 3.1 according to NS-EN 10204. The steel shall be marked in such a way that reference can be made to the delivery certificates.

Tension steel shall satisfy the requirements of ISO 6934

Injection grouting of rock and soils shall satisfy the requirements of NS-EN 12715.

Grouting mortar for use in anchoring zones and for corrosion protection shall satisfy the requirements of NS-EN 447 (1996)

The type of anchorage shall, unless otherwise stated, be selected from among acknowledged systems that can be documented to have been used for similar works. The intended anchoring system shall be specified in *the special specifications*.

Anchoring details shall be specified on the basis of descriptions in *the special specifications*. Plans, drawings and detailed descriptions of work performances shall be submitted to the Project Owner

within an agreed, specified time limit.

Unless otherwise specified in *the special specifications* logs shall be submitted to the Project Owner at the latest 48 hours after the work has been completed. Separate logs shall be recorded for drilling, water loss measurements, grouting of the anchoring zone, installation and casting as well as tensioning operations. Logs shall also be recorded for grouting of free anchor length, corrosion protection and water sealing operations if applicable.

- x) Quantity shall be measured as number of anchorings of each transverse dimension and length. Unit: pcs

83.71 Anchorings in rock

- a) Comprises all works and costs with delivery and installation of complete and approved temporary or permanent anchorings in rock, with or without casing through soils. Also covers preparation of logs for anchorings

- x) Quantity shall be measured as number of anchorings for each transverse dimension and length. Unit: pcs

83.711 Logs for anchorings in rock

- a) Comprises recording of logs for anchorings.

- c) Logs shall contain observed data, be duplicated and distributed as specified in *the special specifications*. Unless otherwise specified the logs shall contain information as specified in specification 83.712.

Furthermore the logs shall contain sufficient information to identify the working site, installation method, length in soils and rock and anchoring level. The logs shall be dated and signed by the foreman in charge of the works and the person responsible for recording logs.

Unless otherwise specified the logs shall be submitted to the Project Owner at the latest 48 hours after the work has been completed.

- x) Costs shall be given as a lump sum. Unit: LS

83.712 Establishing boreholes for anchorings in rock without casings

- a) Comprises all works and materials for establishing borehole, ready for installation of anchoring in accordance with *the special specifications*.

- c) When drilling in rock the contractor shall record rate of penetration, applied force, depths with difficult drilling, gouges and loss of flushing water. Data shall be recorded in the drilling logs with borehole numbers specified.

- d) Tolerances for borehole positioning: ± 50 mm, inclination deviations 2° from the theoretical axis unless otherwise specified in *the special specifications*. The borehole diameter shall be large enough to ensure that the anchor bar will have mortar cover of at least 10 mm.

- x) Quantity shall be measured as completed length of borehole. Unit: m

83.7121 Rigging for drilling in rock without casing

- a) Comprises transportation, rigging and derigging of necessary equipment for borehole drilling as described. Furthermore the specification comprises all costs in connection with establishing a surveying basis for exact positioning of borehole. Does not include transfer between boreholes.

- x) Quantity shall be measured as number of rigging operations. Unit: pcs

83.7122 Drilling and cleaning of borehole in rock without casing

- a) Comprises all works and materials for drilling and cleaning of borehole for drilling mud and loose particles and plugging of hole to prevent foreign particles or soils from entering the hole.

Any additional drilling below the anchoring zone in order to obtain proper cleaning of the anchoring zone shall be included in the unit price.

- x) Quantity shall be measured as length of borehole in rock without casing. Unit: m

83.7123 Water loss measurement in rock without casing

- a) Comprises measurements and recording of water loss, cleaning of drilling mud and other loose particles from the borehole before water loss measurements, positioning of packer and reporting.

- c) Water loss measurements shall be performed according to the following specifications:

- If water flows out of the borehole no water loss measurements shall be performed, but grouting shall be carried out directly unless otherwise decided by the Project Owner.

- Boreholes without water flowing out of the borehole shall be filled with water. If the water level does not drop, no water loss measurements shall be performed. If the water level falls, water loss measurements shall be performed with packer positioned in the upper part of the borehole. Applied pressure and duration shall be as specified in *the special specifications*. For boreholes with particularly large water leakages, it shall be decided in consultation with the Project Owner whether pressure grouting should be used.

For water loss measurements the following apply:

- The borehole shall be flushed clean immediately before water loss measurements.
- A single packer shall be used.
- Manometers shall have be sufficiently accurat to work with controlled pressures in the range of 0.5-5 bar.
- Water quantities shall be measured with equipment capable of measuring both small and large water quantities with satisfactory accuracy.
- Water losses shall be measured during 5 minute periods until two subsequent measuring periods show Differences of less than 10%.
- Water losses shall be specified in Lugeon (L). (1 L corresponds to 1 litre per minute per metre bore hole at 10 bar overpressure). When other overpressures are used, the water loss may in simplified form be regarded as proportional to pressure.

- x) Quantity shall be measured as number of water loss measurements. Unit: pcs

83.7124 Injection grouting of fissured rock in boreholes

- a) Comprises injection grouting where water loss measurements or other observations indicate that injection grouting as specified in *the special specifications* is required. The specification also covers preparation of reports showing borehole number, position of packer, pressure applied, grout mix design and volume of grout injected in each hole in accordance with NS-EN 12715, point 10.3.

Redrilling of injected boreholes and repeated water loss measurements shall be settled according to specifications 83.7122 and 83.71 23.

- b) The contractor shall be able to document that all equipment and materials used for injection purposes are adjusted to the applied injection pressures. Precautions shall be taken to prevent packers/bulbs suddenly being ejected from the borehole. It shall be possible to open and close packers as required.

Materials shall satisfy NS-EN 1271 5:2000, point 6. The injection grout shall be handled according to NS-EN 1271 5:2000, point 8.3. Materials shall be stored under dry and frost free conditions, and otherwise as specified by the supplier. Old materials and materials stored under unfavourable conditions shall not be used.

Standard injection cement that satisfies the requirements of CEM I 42.5 RR in accordance with NS 3086 shall be used. Super-plasticizing ingredients shall be added to the injection grout. Other additives shall not be used except in agreement with the Project Owner.

- c) Safe job analyses (SJA) shall include the use of injection packers and bulbs, installation, safety measures, supervision and dismantling.

At least one person shall have documented experience of similar injection works.

Injection works shall be organized so that the work is not terminated before injection of a borehole is completed.

Variable factor such as injection pressure, pump velocity etc. shall be determined on the basis of local conditions or otherwise as specified in the special contract conditions.

The mixing ratio w/c+s shall normally lie within the range 1.0-0.5, and shall be determined on the basis of observed water leakages and other local conditions. Other mixing ratios shall not be used except by agreement with the Project Owner.

For injection purposes the packer shall be positioned at the top of the anchoring zone. Stop criteria shall be given in *the special specifications* or determined by the Project Owner on site. Criteria shall be given as overpressure when terminating the injection or as injected volume of grout. When pressure builds up the injection shall be terminated with a thicker grout. If the maximum specified volume of grout per hole is applied without reaching the specified counter pressure, the injection pumping shall be stopped and the Project Owner notified. Unless otherwise specified in *the special specifications* a quantity of 400 kg shall be regarded as the maximum quantity.

If, during the injection process, injection grout is ejected from other holes, packers shall be installed in these holes. Further injection shall be performed by alternating or simultaneous injections in the holes.

Injected holes shall not be redrilled before the grout has sufficient strength for drilling operations to be performed without danger of wash-out.

- x) Quantity shall be measured as supplied quantity of injection materials without water. Unit: kg

83.71241 Rigging and derigging for injection grouting

- a) Comprises rigging and derigging of equipment for injection purposes.

- x) Quantity shall be measured as number of rigging positions. Unit: stk.

83.71242 Positioning of packers

- a) Comprises delivery of packers and positioning of packers in borehole.

- c) Packers shall be placed at the top of the anchoring zone unless otherwise specified in *the special specifications*.
- x) Quantity shall be measured as number of packer placements. Unit: pcs

83.71243 Injection grouting

- a) Comprises delivery of injection materials including additives as well as pumping operations.
- x) Quantity shall be measured as supplied quantity of injection materials without water. Unit: kg

83.713 Establishment of boreholes for anchorings in rock with casing in soils

- a) Comprises all works and materials required up to a finished borehole, ready for installation of anchorings in accordance with *the special specifications*.
- c) When drilling in rock the contractor shall record rate of penetration, applied force, depths with difficult drilling, gouges and loss of flushing water. When drilling with casing in soils, applied flushing pressure and any soil erosion shall also be recorded. Data shall be recorded in the drilling logs with borehole numbers specified.
- d) Tolerance for borehole positioning: ± 50 mm, inclination deviations 2° from the theoretical axis unless otherwise specified in *the special specifications*. The borehole diameter shall be large enough to ensure that the anchor bar will have at least 10 mm of mortar cover.
- x) Quantities shall be measured as completed length of borehole. Unit: m

83.7131 Rigging for drilling in rock with casing in soils

- a) Comprises transportation, rigging and derigging of equipment necessary for drilling with casing in soils, in the transition zone above rock as described, as well as drilling in rock. The specification also covers all costs in connection with establishing a surveying basis for exact positioning of boreholes.
- x) Quantity shall be measured as number of rigging positions. Unit: pcs

83.7132 Drilling with casing in soils

- a) Comprises drilling with casing through soils and the transition zone above rock for rock anchorings through soils. Also covers making holes through supporting structures.
- b-c) When making holes through supporting structures before installing casings the best possible sealing arrangement shall be aimed at in order to prevent leakage of water or soils through the hole.
Unless otherwise stated in *the special specifications*, the borehole shall penetrate at least 0.5 m into solid rock in the transition zone between soils and rock.
- x) Quantity shall be measured as completed length of borehole with casing. Unit: m

83.7133 Drilling and cleaning of boreholes in rock through casing

- a) Comprises all works and materials for drilling and cleaning drill mud and loose particles from boreholes and if necessary plugging casing to prevent foreign particles or soils from entering the hole.
Additional drilling below the anchoring zone to permit proper cleaning of the anchoring zone shall be included in the unit price if applicable.
- x) Quantity shall be measured as completed length of borehole in rock with casing. Unit: m

83.7134 Water loss measurement in rock through casing

- a) As in specification 83.7123.
- c) Water loss measurements shall be performed according to the following specifications:
 - If water flows out of the casing a packer shall be installed at the top of the anchoring zone in rock. If the water flow remains constant, the Project Owner shall decide if it is necessary to seal openings between casing and rock. If the water flow slows noticeably, water loss measurements shall be performed.
 - Casings with no water flow shall be filled with water. If the water level does not drop noticeably within 1 hour, the Project Owner shall decide whether water loss measurements need to be performed. In this case the groundwater level shall be checked against the water level at the top of the casing. In the case of falling water levels, water loss measurements shall be performed with packer positioned in the upper part of the rock borehole. Pressure applied and duration shall be as specified in *the special specifications*. The lower level for permissible water loss shall also be specified here. For boreholes with particularly large water leakages, it shall be decided in consultation with the Project Owner whether pressure grouting or deeper drilling should be used.
 - Water loss measurements shall be performed for all permanent anchorings that are not injected directly.

The following applies to water loss measurements :

- The borehole shall be flushed clean immediately before water loss is measured.
- A single packer shall be used.
- Manometers shall have sufficient accuracy to work with controlled pressures in the range of 0.5-5 bar.
- Water quantities shall be measured with equipment suitable for measuring both small and large water quantities with satisfactory accuracy.
- Water losses shall be measured during 5 minute periods until two subsequent measuring periods show differences of less than 10%.
- Water losses shall be specified in Lugeon (L). (1 L corresponds to 1 litre per minute per metre of borehole at 10 bar overpressure). When other overpressures the water loss may be regarded in simplified form as being proportional to pressure.

- x) Quantity shall be measured as number of water loss measurements for each borehole. Unit: Pcs

83.7135 Injection grouting of fissured rock in borehole through casing

- a-c) As in specification 83.7124.

- x) Quantity shall be measured as supplied quantity of injection materials without water. Unit: kg

83.71351 Rigging and derigging for injection grouting through casing

- a) Comprises rigging and derigging of injection equipment.

- x) Quantity shall be measured as number of riggings. Unit: pcs

83.71352 Positioning of packer

- a) Comprises delivery and positioning of packers in borehole in rock.

- c) Packers shall be placed at the top of the anchoring zone unless otherwise stated in *the special specifications*. For sealing of openings between casing and bedrock the packer shall be positioned near the bottom of the casing.

- x) Quantity shall be measured as number of packer positions. Unit: pcs

83.71353 Injection grouting

- a) Comprises delivery of injection materials including any additives as well as pumping operations.

- x) Quantity shall be measured as supplied quantity of injection materials without water. Unit: kg

83.714 Delivery of temporary tension cables for anchorings in rock

- a) Comprises delivery of complete temporary anchorings including anchoring heads and bearing plates or other visible anchoring units

- x) Quantity shall be measured as number of anchoring bars for each transverse dimension and length. Unit: pcs

83.7141 Drawings and descriptions of temporary tension cables

- a) Comprises preparation of detailed drawings and working procedures for installation, grouting and tensioning of temporary tension cables. Also covers preparation of tensioning lists.

- x) Costs shall be given as a lump sum. Unit: LS

83.7142 Delivery of tension cables for temporary anchorings in rock

- a) Comprises delivery of tension cables with dimensions and lengths as specified in *the special specifications*.

- x) Quantity shall be measured as length of tension cables with specified capacity from the bottom of the anchoring zone to the exposed anchoring head. Unit: m

83.7143 Delivery of anchoring accessories for temporary tension cables in rock

- a) Comprises anchoring heads as well as bearing plates for anchor dimensions as specified in *the special specifications*.

- x) Quantity shall be measured as number of anchorings for anchor dimensions as specified in *the special specifications*. Unit: pcs

83.7144 Installation and grouting of temporary tension cables for anchorings in rock

- a) Comprises installation and grouting in rock of anchorings with or without casings. Also covers construction of concrete foundation on rock if applicable.

- b-c) Requirements regarding concrete foundation shall be specified in *the special specifications*. The grouting mortar used shall be cement-based and have a w/c ratio = 0.4 or less. The grout mix design and use of additives shall be submitted to and accepted by the Project Owner before work commences. The grouting mortar shall have a consistency that permits pumping down to the borehole bottom as well as preventing wash-outs in water. Density tests on mortar samples taken from the mixing plant

shall be in accordance with theoretically calculated values ± 0.02 kg/litre.

The borehole in rock shall be filled with mortar through a grouting hose from the bottom of the hole to the top of the anchoring zone before tendons are individually inserted into the hole. If anchorings are inserted into the hole before the grouting operation, sufficient space shall be available between the individual tendons in order for the grouting mortar to penetrate between the bundles of tendons.

Immediately after installation and grouting have been performed, excess grouting mortar shall be flushed away by a horizontally directed water jet above the top of the anchoring zone. The minimum free anchor length shall be 5 m.

- e) The density of the grouting mortar shall be checked once per batch. The density of excess mortar from the hole shall be checked once per anchoring. If density measurements from each batch show satisfactory results, the testing frequency may be reduced to once per working shift.
- x) Quantity shall be measured as number of anchorings with anchor dimensions and lengths as specified in *the special specifications*. Unit: pcs

83.7145 Tensioning of temporary tension cables in rock

- a) Comprises tensioning to specified test level, locking of test load at specified level, later adjustments to the tension load and cutting of surplus tension steel.
- b-c) It is the responsibility of the contractor to ensure that the grouting mortar has reached a strength of at least B30 before tension testing/tensioning of the anchorings is performed.

It is the responsibility of the contractor to ensure that the anchorings can be satisfactorily locked within a loading range of 25-60% of the yield strength ($f_{0.2}$) of the anchor cable unless otherwise stated in *the special specifications*.

All tendons in the anchoring unit shall be tensioned simultaneously.

Tensioning shall be performed in steps and both the relative and the absolute deformation of the anchor shall be recorded for each load step. This shall be done by recording the relative deformation between the jack and the tendons and at the same time recording the deformation of the tendons in relation to a fixed benchmark.

Before tensioning takes place the tensioning equipment (jack and manometer) shall be calibrated and documentation submitted to the Project Owner.

The first three anchorings shall be tensioned according to the procedure below:

- Removal of slack in tendons. Zero position for extension measurements shall be defined as the position with $0.1P$ (P = test load) or minimum 10 kN per tension rope.
- The anchoring shall be loaded in steps with readings for at least the following loads: $0.1P$, $0.4P$, $0.7P$ and $1.0P$. The load at each step shall remain unchanged until deformations are less than 1 mm over a period of 2 minutes. The test load P shall be applied unchanged until zero deformations are recorded over a period of 10 minutes with readings of both load and deformation after 5 and 10 minutes.
- The anchoring shall be unloaded down to $0.1P$ and then a new initiating measurement shall be performed.
- From $0.1P$ the anchoring shall be loaded directly and locked for the pre-tensioning load.

For all other anchorings, the procedure regarding slack removal shall be performed, after which the test load shall be applied. The test load shall be applied to the anchoring until zero deformations are recorded over a period of at least 10 minutes with readings after both 5 and 10 minutes. The anchoring shall then be locked for the pre-tensioning load.

When locking loads are established, compensation for loss of locks shall be made by over-tensioning the anchoring with a load corresponding to lock-loss-deformations in the corresponding loading interval. Lock-loss deformations shall be specified.

Cutting of tension ropes above the anchoring head shall only take place with the consent of the Project Owner.

- e) Anchoring deformations shall have stabilised during the observation period. Measured elastic extension shall furthermore correspond to calculated values within +10% / -20%. For anchorings with a free length of more than 20 m the maximum deviation for elastic extensions shall correspond to +2 m / -4 m free anchor length.
- x) Quantity shall be measured as number of anchorings with dimensions as specified in *the special specifications*. Unit: pcs

83.7146 Adjustment of tension loads in tension cables

- a-c) Comprises adjustment of tension loads related to deformations of retaining structures as specified in *the special specifications*.
- x) Quantity shall be measured as number of anchorings with dimensions as specified in *the special specifications*. Unit: pcs

83.715 Delivery of permanent tension cables for anchorings in rock

- a) Comprises delivery of complete, permanent tension cables including anchoring heads and bearing plates or other visible anchoring units
- x) Quantity shall be measured as number of anchoring bars for each transverse dimension and length. Unit: pcs

83.7151 Drawings and descriptions of permanent tension cables

- a) Comprises preparation of detailed drawings and working procedures for installation, grouting and tensioning of permanent tension cables. Also covers preparation of tensioning lists.
- x) Costs shall be given as a lump sum. Unit: LS

83.7152 Delivery of tension cables for permanent anchorings in rock

- a) Comprises delivery of tension cables with dimensions and lengths as specified in *the special specifications*.
- b-c) Permanent anchorings shall be constructed as follows:
 - Tension ropes shall be of types with double corrosion protection as specified in NS-EN 1537, Table 3.
 - Outside the tension zone the tension cable shall be equipped with factory-applied grease and plastic tube.
 - In the anchoring zone the tension cables shall be degreased.
 - The anchoring zone shall at least be 4 m in length and the free rope length at least 5 m
 - The tension cable shall be equipped with a corrugated plastic tube in the anchoring zone.
 - Both tension cable and corrugated tube shall have non-metallic spacers in order to ensure central alignment. The spacers shall not obstruct the free flow of grouting mortar. The spacer system shall be approved by the Project Owner.
- x) Quantity shall be measured as linear metres of tension cables with specified capacities from the bottom of the anchoring zone to the visible anchoring head. Unit: m

83.7153 Delivery of anchoring accessories for permanent tension cables in rock

- a-x) As in specification 87.71 43. Unit: pcs

83.7154 Installation and grouting of permanent tension cables for anchorings in rock

- a) Comprises installation and grouting in rock of anchorings with or without casings. Also covers construction of concrete foundation on rock if applicable

Requirements regarding concrete foundation are specified in *the special specifications*.

The grouting mortar used shall be cement-based and have a w/c ratio = 0.4 or less. The grout mix design and use of additives shall be submitted to and accepted by the Project Owner before work commences. The grouting mortar shall have a consistency that permits pumping down to the borehole bottom as well as preventing wash-outs in water. Density tests on mortar samples taken from the mixing plant shall be in accordance with theoretically calculated values ± 0.02 kg/litre. Densities of excess grouting mortar being pumped out of the borehole shall not be more than 0.05 kg/l lower than the theoretically calculated value.

- c) The completed, installed tension cable shall have grouting hoses outside and inside the corrugated plastic tube.

The following procedure shall be used when installing and grouting the anchorings:

- The complete, assembled tension cable shall be inserted into the cleaned hole.
- Before grouting, the cable shall be centred at the top by means of the anchor head.
- Grouting shall be performed simultaneously inside and outside the grouting hose until grout is extruded on both sides of the corrugated tube.
- When grouting is completed a system shall be arranged for post-grouting of all cavities in the top of the anchoring that cannot be grouted by the procedure described above.

- e) The density of the grouting mortar shall be checked once per batch. The density of excess mortar from the hole shall be checked once per anchoring. If density measurements from each batch show satisfactory results the testing frequency may be reduced to once per working shift.
- x) Quantity shall be measured as number of anchorings with anchor dimensions and lengths as specified in *the special specifications*. Unit: pcs

83.7155 Tensioning of permanent tension cables in rock

- a-b) As in specification 83.71 45.
- c) All anchorings shall be tensioned in steps. After cutting of tendons, corrosion protection of the anchoring head shall be installed immediately, unless otherwise stated in *the special specifications*. Otherwise according to 83.7145
- x) As in specification 83.71 45. Unit: pcs

83.7156 Adjustment of tension loads

- a-x) As in specification 83.71 46. Unit: pcs

83.716 Delivery of temporary anchoring rods for anchorings in rock

- a) Comprises delivery of complete temporary anchorings including anchoring heads and bearing plates or other visible anchoring units
- x) Quantity shall be measured as number of anchoring rods of each transverse dimension and length. Unit: pcs

83.7161 Drawings and descriptions of temporary anchoring rods

- a) Comprises preparation of detailed drawings and working procedures for installation, grouting and tensioning of temporary anchorings. Also covers preparation of tensioning lists.
- x) Costs shall be given as a lump sum. Unit: LS

83.7162 Delivery of steel rods for temporary anchorings in rock

- a) Comprises delivery of steel rods with transverse dimensions and lengths as specified in *the special specifications*.
- b-c) If requirements regarding free anchor lengths are specified in *the special specifications*, the anchor may be equipped with a smooth plastic tube over the free length.
- x) Quantity shall be measured as linear metres of anchoring with specified capacity from the bottom of the anchoring zone to the visible anchor head. Unit: m

83.7163 Delivery of anchoring accessories for temporary anchoring rods in rock

- a) Comprises locking nuts and bearing plates for anchor dimensions as specified in *the special specifications*.
- x) Quantity shall be measured as number of anchorings for dimensions as specified in *the special specifications*. Unit: pcs

83.7164 Installation and grouting of temporary anchoring rods in rock

- a) Comprises installation and grouting of anchors in rock with or without casing. Also covers construction of concrete foundation on rock if applicable.
- b-c) Requirements regarding concrete foundation shall be specified in *the special specifications*. The grouting mortar used shall be cement-based and have a w/c ratio = 0.4 or less. The grout mix design and use of additives shall be submitted to and accepted by the Project Owner before work commences. The grouting mortar shall have a consistency that permits pumping down to the borehole bottom as well as preventing wash-outs in water. Density tests on mortar samples taken from the mixing plant shall be in conformity with a theoretically calculated value of ± 0.02 kg/litre.

The rock borehole shall be filled with mortar through a grouting hose from the bottom of the hole to the top of the anchoring zone or top of the hole before the anchor is inserted into the hole. The anchor shall be equipped with spacers in order to assure proper centring in the hole.

For anchors with free anchor lengths any excess mortar shall be removed by a horizontally directed water jet above the top of the anchoring zone if the anchor is not equipped with a plastic tube. . Minimum free anchor lengths shall be specified in *the special specifications*.
- e) The density of the grouting mortar shall be checked once per batch. The density of excess mortar from the hole shall be checked once per anchoring. If density measurements from each batch show satisfactory results, the testing frequency may be reduced to once per working shift.
- x) Quantity shall be measured as number of anchorings with anchor dimensions and lengths as specified in *the special specifications*. Unit: pcs

83.7165 Tensioning of temporary anchoring rods with anchoring in rock

- a) Comprises tensioning to specified load and locking.
- b-c) It is the responsibility of the contractor to ensure that the grouting mortar has reached a strength of at least B30 before tension testing/tensioning of the anchorings is performed. Loading procedures shall be as specified in *the special specifications*. During tensioning the relative deformation between the jack and the anchor shall be recorded at the same time as deformation of the anchor in relation to a fixed benchmark.
- x) Quantity shall be measured as number of anchors with dimensions as specified in *the special specifications*. Unit: pcs

83.7166 Locking of temporary anchoring rods with anchoring in rock

- a) Comprises locking of anchorings without tensioning.
- c) Locking nuts shall be tightened with a torque wrench to the specified torque resistance.
- x) Quantity shall be measured as number of anchorings. Unit: pcs

83.7167 Adjustment of tension loads

- a-x) As in specification 83.71 46. Unit: pcs

83.717 Delivery of permanent anchoring rods for anchoring in rock

- a) Comprises delivery of complete temporary anchorings including anchoring heads and bearing plates or other visible anchoring units
- x) Quantity shall be measured as number of anchoring rods for each transverse dimension and length. Unit: pcs

83.7171 Drawings and descriptions of permanent anchoring rods

- a) Comprises preparation of detailed drawings and working procedures for installation, grouting and tensioning of permanent anchoring rods. Also covers preparation of tensioning lists.
- x) Costs shall be given as a lump sum. Unit: LS

83.7172 Delivery of steel rods for permanent anchorings for anchoring in rock

- a) Comprises delivery of steel rods with dimensions and lengths as specified in *the special specifications*.
- b-c) Rods shall be delivered complete with corrosion protection made of cement-grouted corrugated tube over the whole length and as smooth tube at the free end if applicable.
- x) Quantity shall be measured as linear metres of anchorings with specified capacity from the bottom of the anchoring zone to the visible anchoring head. Unit: m

83.7173 Delivery of anchoring accessories for permanent anchorings for anchoring in rock

- a-x) As in specification 83.7163. Unit: pcs

83.7174 Installation and grouting of permanent anchoring rods for anchoring in rock

- a) Comprises installation and grouting of anchoring rods in rock with or without casing. Also covers construction of concrete foundation on rock if applicable.
- b-c) Requirements regarding concrete foundation shall be specified in *the special specifications*.

The grouting mortar used shall be cement-based and have a w/c ratio = 0.4 or less. The grout mix design and use of additives shall be submitted to and accepted by the Project Owner before work commences. The grouting mortar shall have a consistency that permits pumping down to the borehole bottom as well as preventing wash-outs in water. Density tests on mortar samples taken from the mixing plant shall be in accordance with theoretically calculated values ± 0.02 kg/litre.

Densities of excess grouting mortar being pumped out of the borehole shall not be more than 0.05 kg/l lower than the theoretically calculated value.

The borehole shall be filled with mortar through a grouting hose from the bottom of the hole to the top of hole before the anchor is inserted into the hole. The anchor shall be equipped with spacers in order to ensure proper centring in the hole.

- e) The density of the grouting mortar shall be checked once per batch. The density of excess mortar from the hole shall be checked once per anchoring. If density measurements from each batch show satisfactory results the testing frequency may be reduced to once per working shift.
- x) Quantity shall be measured as number of anchorings with anchor dimensions and lengths as specified in *the special specifications*. Unit: pcs

83.7175 Tensioning of permanent anchoring rods for anchoring in rock

- a-x) As in specification 83.7165. Unit: pcs

83.7176 Locking of permanent anchoring rods with anchoring in rock

- a-x) As in specification 83.7166. Unit: pcs

83.7177 Adjustment of tension loads with anchoring in rock

- a-x) As in specification 83.71 46. Unit: pcs

83.72 Anchorings in soils

- a) Comprises all works and costs with delivery and installation of complete and approved temporary and permanent anchorings in soils with or without pre tensioning.
- x) Quantity shall be measured as number of anchorings of each transverse dimension and length. Unit: pcs

83.721 Logs of anchorings in soils

- a-x) See *the special specifications*. Unit: LS

83.722 Establishing borehole for anchorings

- a) Comprises all works and any materials resulting in a completed borehole prepared for installation of anchorings in accordance with *the special specifications*.

- c) When drilling with casing in soils the water flushing pressure and any erosion of soils shall be stated. Data shall be recorded in the borehole logs with borehole number stated.
 - d) Tolerances for positioning: ± 50 mm, borehole deviation 2° from the theoretical axis unless otherwise stated in *the special specifications*.
 - x) Quantity shall be measured as completed length of borehole. Unit: m
- 83.7221 Rigging for drilling with casing in soils**
- a) Comprises transportation, rigging and derigging of equipment necessary for drilling with casing in soils. Furthermore the specification covers all costs in connection with establishing a surveying basis for exact positioning of boreholes.
 - x) Quantity shall be measured as number of riggings. Unit: pcs
- 83.7222 Drilling with casing in soils**
- a) Comprises drilling with casing through soils. Also covers establishing holes through supporting structures.
 - b-c) When establishing holes through supporting structures a best possible sealing arrangement shall be aimed at in order to prevent leakages of water or soils through the hole.
 - x) Quantity shall be measured as completed length of borehole with casing. Unit: m
- 83.723 Delivery of temporary tension cables for anchorings in soils**
- a) Comprises delivery of complete temporary tension cables including anchoring heads and bearing plates or other visible anchoring units.
 - x) Quantity shall be measured as number of anchorings for each transverse dimension and length. Unit: pcs
- 83.7231 Drawings and descriptions of temporary tension cables**
- a) Comprises preparation of detailed drawings and working procedures for installation, grouting and tensioning of temporary tension cables. Also covers preparation of tensioning lists.
 - x) Costs shall be given as a lump sum. Unit: LS
- 83.7232 Delivery of tension cables for temporary anchorings in soils**
- a) Comprises delivery of tension cables with dimensions and lengths as specified in *the special specifications*.
 - b-c) Anchoring systems in soils, e.g. soil injection or use of expander bodies as specified in *the special specifications*.
 - x) Quantity shall be measured as linear metres of anchorings with specified capacity from the bottom of the anchoring zone to the visible anchoring head. Unit: m
- 83.7233 Delivery of anchoring accessories for temporary tension cables in soils**
- a) Comprises anchoring heads with cotter bolts as well as bearing plates for anchor dimensions as specified in *the special specifications*.
 - x) Quantity shall be measured as number of anchorings for dimensions as specified in *the special specifications*. Unit: pcs
- 83.7234 Installation and anchoring of temporary tension cables in soils**
- a) Comprises complete installations of soil anchorings including extraction of casing if applicable.
 - b-c) Requirements regarding materials and execution procedures shall be as specified in *the special specifications*. Minimum free anchoring length shall be 5 m.
 - x) Quantity shall be measured as number of anchorings with dimensions and lengths as specified in *the special specifications*. Unit: pcs
- 83.7235 Tensioning of temporary tension cables in soils**
- a) Comprises tensioning to specified test level for approval testing, locking of test load at specified level, later adjustments to the tension load and cutting of surplus tension steel.
Performance of suitability tests is specified in specification 83.73.
 - b) It is the responsibility of the contractor to ensure that the grouting mortar has reached a strength of at least B30 before tension testing/tensioning of the anchorings is performed.
Acceptance testing shall be performed in accordance with test method 3 specified in NS-EN 1537 (stepwise tensioning without unloading between steps).
 - c) All tendons in the anchoring unit shall be tensioned simultaneously.
With stepwise tensioning both the relative and the absolute deformation of the anchor shall be recorded for each load step. This shall be performed by recording the relative deformation between the jack and the tension rope and at the same time recording the deformation of the tension rope in relation to a fixed benchmark.

Before tensioning is performed the tensioning equipment (jack and manometer) shall be calibrated and documentation submitted to the Project Owner.

All anchorings shall be tensioned according to the procedure below:

- Removal of slack in tendons. Zero position for extension measurements shall be defined as the position with 0.1xP (P = test load) or minimum 10 kN per tension rope.
- The anchoring shall be loaded in steps with readings for at least the following loads: 0.1 P, 0.4P, 0.7P and 1.0P. The load at each step shall remain unchanged until deformations are less than 1 mm over a period of 2 minutes. At test load P the displacements caused by creep shall be measured between the 3rd and 15th minute. Maximum permissible creep shall be according to NS-EN 1537, chapter E.4.3.
- The anchoring shall be unloaded down to 0.1 P and then a new initiating measurement shall be performed.
- From 0.1 P the anchoring shall be loaded directly and locked for the pretensioning load.

When locking loads are established, compensation for loss of locks shall be made by over-tensioning the anchoring by a load corresponding to lock-loss deformations in the corresponding loading interval. Lock-loss deformations shall be specified.

Cutting of tension ropes above the anchoring head shall only be performed with the consent of the Project Owner.

- e) Anchoring deformations shall have stabilised during the observation period. Measured elastic extension shall furthermore correspond to calculated values within +10% / -20%. For anchorings with a free length of more than 20 m the maximum deviation for elastic extensions shall correspond to +2 m / -4 m free anchor length.
- x) Quantity shall be measured as number of anchorings with dimensions as specified in *the special specifications*. Unit: pcs

83.7236 Adjustment of tension loads in tension cables

- a-x) As in specification 83.71 46. Unit: pcs

83.724 Delivery of permanent tension cables for anchorings in soils

- a) Comprises delivery of complete, permanent tension cables including anchoring heads and bearing plates or other visible anchoring units.
- x) Quantity shall be measured as number of anchorings for each transverse dimension and length. Unit: pcs

83.7241 Drawings and descriptions of permanent tension cables for anchoring in soils

- a) Comprises preparation of detailed drawings and working procedures for installation, grouting and tensioning of permanent tension cables. Also covers preparation of tensioning lists.
- x) Costs shall be given as a lump sum. Unit: LS

83.7242 Delivery of tension cables for permanent anchorings in soils

- a-x) As in specification 83.7152. Unit: m

83.7243 Delivery of anchoring accessories for permanent tension cables in soils

- a-x) As in specification 83.7233. Unit: pcs

83.7244 Installation and anchoring of permanent tension cables in soils

- a-x) As in specification 83.7234. Unit: pcs

83.7245 Tensioning of permanent tension cables in soils

- a-x) As in specification 83.7235. Unit: pcs

83.7246 Adjustment of tension loads in tension cables

- a-x) As in specification 83.71 46. Unit: pcs

83.725 Delivery of temporary anchoring rods for anchorings in soils

- a) Comprises delivery of complete, temporary anchoring rods including anchoring heads and bearing plates or other visible anchoring units.
- x) Quantity shall be measured as number of anchorings for each transverse dimension and length. Unit: pcs

83.7251 Drawings and descriptions of temporary anchoring rods in soils

- a) Comprises preparation of detailed drawings and working procedures for installation, grouting and tensioning of anchorings. Also covers preparation of tensioning lists.
- x) Costs shall be given as a lump sum. Unit: LS

83.7252 Delivery of tension rods for temporary anchorings in soils

- a) Comprises tension bars with dimensions and lengths as specified in *the special specifications*.

- c) Anchoring systems in soils, e.g. soil injection or use of expander bodies as specified in *the special specifications*.
 - x) Quantity shall be measured as linear metres of anchorings with specified capacity from the bottom of the anchoring zone to the visible anchoring head. Unit: m
- 83.7253 Delivery of anchoring accessories for temporary anchoring rods in soils**
- a-x) As in specification 83.7163. Unit: pcs
- 83.7254 Installation and anchoring of temporary anchoring rods in soils**
- a) Comprises complete installations of soil anchorings including extraction of casing if applicable.
 - b-c) Requirements regarding materials and execution procedures shall be as specified in *the special specifications*.
 - x) Quantity shall be measured as number of anchorings with dimensions and lengths as specified in *the special specifications*. Unit: pcs
- 83.7255 Tensioning of temporary anchoring rods in soils**
- a) Comprises tensioning to specified test level for approval testing, locking of test load at specified level, later adjustments to the tension load and cutting of surplus tension steel.

Performance of suitability tests is specified in specification 83.73.
 - b) It is the responsibility of the contractor to ensure that the grouting mortar has reached a strength of at least B30 before tension testing/tensioning of the anchorings is performed.
 - c) Acceptance testing shall be performed in accordance with test method 3 in NS-EN 1537 (stepwise tensioning without unloading between steps).

When several anchoring rods are used in the anchoring, all rods shall be tensioned simultaneously.

With stepwise tensioning both the relative and the absolute deformation of the anchor shall be recorded for each load step. This shall be performed by recording the relative deformation between the jack and the tension rod and at the same time recording the deformation of the tension rod in relation to a fixed benchmark.

Before tensioning is performed the tensioning equipment (jack and manometer) shall be calibrated and documentation submitted to the Project Owner.

All anchorings shall be tensioned according to the procedure below:
- Zero position for extension measurements shall be defined as the position with 0.1xP (P = test load) or minimum 10 kN.
- The anchoring shall be loaded in steps with readings for at least the following loads: 0.1 P, 0.4P, 0.7P and 1.0P. The load at each step shall remain unchanged until deformations are less than 1 mm over a period of 2 minutes. At test load P the displacements caused by creep shall be measured between the 3rd and 15th minute. Maximum permissible creep shall be according to NS-EN 1537, chapter E.4.3.
- The anchoring shall be unloaded down to 0.1 P and then a new initiating measurement shall be performed.
- From 0.1 P the anchoring shall be loaded directly and locked for the pretensioning load.
 - e) Anchoring deformations shall have stabilised during the observation period. Measured elastic extension shall furthermore correspond to calculated values within +10% / -20%. For anchorings with a free length of more than 20 m, the maximum deviation for elastic extensions shall correspond to +2 m / -4 m free anchor length.
 - x) Quantity shall be measured as number of anchorings with dimensions as specified in *the special specifications*. Unit: pcs
- 83.7256 Adjustment of tension loads for tension rods in soils**
- a-x) As in specification 83.71 46. Unit: pcs
- 83.726 Delivery of permanent anchoring rods for anchoring in soils**
- a) Comprises delivery of complete, permanent anchoring rods including anchoring heads and bearing plates or other visible anchoring units.
 - x) Quantity shall be measured as number of anchorings of each transverse dimension and length. Unit: pcs
- 83.7261 Drawings and descriptions of permanent anchoring rods in soils**
- a) Comprises preparation of detailed drawings and working procedures for installation, grouting and tensioning of permanent anchoring rods. Also covers preparation of tensioning lists.
 - x) Costs shall be given as a lump sum. Unit: LS
- 83.7262 Delivery of steel rods for permanent anchorings in soils**
- a-x) As in specification 83.7172. Unit: m

- 83.7263 Delivery of anchoring accessories for permanent anchoring rods in soils**
a-x) AS in specification 83.7163. Unit: pcs
- 83.7264 Installation and anchoring of permanent anchoring rods in soils**
a-x) As in specification 83.7254. Unit: pcs
- 83.7265 Tensioning of permanent anchoring rods in soils**
a-x) As in specification 83.7255. Unit: pcs
- 83.7266 Adjustment of tension loads in anchoring rods**
a-x) As in specification 83.71 46. Unit: pcs
- 83.73 Suitability tests for anchorings in soils**
- a) Comprises tensioning with a long observation period in accordance with procedures specified in NS-EN 1537.
 - c) Tensioning procedure shall be selected on the basis of soil type and as specified in *the special specifications*.
 - x) Quantity shall be measured as number of tensioning procedures for anchorings with dimensions as specified in *the special specifications*. Unit: pcs
- 83.74 Completing works for anchorings**
- a) Comprises completing works for permanent and temporary anchorings as specified in *the special specifications*.
 - x) Quantity shall be measured as number of anchorings. Unit: pcs
- 83.741 Corrosion protection of anchorings with tension cables**
- a) Comprises corrosion protection of permanent or temporary anchorings as specified in *the special specifications*.
 - x) Quantity shall be measured as number of anchorings. Unit: pcs
- 83.742 Corrosion protection of anchorings with anchoring rods**
- a) Comprises corrosion protection of permanent or temporary anchorings as specified in *the special specifications*.
 - x) Quantity shall be measured as number of anchorings. Unit: pcs
- 83.743 Sealing of holes through supporting structures**
- a) Comprises sealing of holes through supporting structures as specified in *the special specifications*.
 - x) Quantity shall be measured as number of anchorings. Unit: pcs
- 83.744 Sealing of casings and anchorings**
- a) Comprises sealing of casings and anchorings as specified in *the special specifications*.
 - x) Quantity shall be measured as number of anchorings. Unit: pcs
- 83.745 Protection of anchorings in retaining walls**
- a) Comprises protection of permanent or temporary anchorings as specified in *the special specifications*.
 - x) Quantity shall be measured as number of anchorings. Unit: pcs
- 83.746 Special documentation of permanent anchorings in retaining walls**
- a) Comprises collection of data and preparation of special documentation for anchorings as specified in *the special specifications* in addition to specifications otherwise available in specification 83.7.
 - x) Costs shall be given as a lump sum. Unit: LS
- 83.75 Removal of temporary anchorings**
- a) Comprises detensioning and removal of temporary anchorings, fully or partly, as specified in *the special specifications*. Sealing of casings shall be performed as specified in specification 83.744 if applicable.
 - b-c) Anchorings shall only be removed when the supporting structure has been secured against unwanted deformations.

Detensioning shall be performed in a controlled manner using a jack. Afterwards the tendons and casings shall be cut at a position as specified in *the special specifications*.

The Project Owner shall be notified 3 days in advance before detensioning is performed. All materials shall be removed as the property of the contractor.
 - x) Quantity shall be measured as number of anchorings. Unit: pcs

83.76 Special anchoring works

83.761 Anchoring of sheet pile footings with inclined bolts in rock welded to the sheet pile

- a) Comprises drilling of boreholes to a specified depth in rock, delivery of bolts and grouting mortar, all works in connection with installation of bolts and welding of bolts to sheet piles.
- b) Bolt dimensions shall be specified in *the special specifications*. Bolts shall be made of cam steel of grade B500C. Corrosion protection shall be applied as specified in *the special specifications* if applicable. Cement mortar for grouting shall have a w/c ratio of 0.4 or less.
- c) The bolts shall be fully grouted in rock. The holes shall be grouted by means of a hose from the bottom of the hole. Details regarding other parts of the working procedures shall be as specified in *the special specifications*.
- x) Quantity shall be measured as number of bolts. Units: pcs

83.762 Anchoring of sheet pile footing with a concrete girder anchored with inclined bolts in rock

- a) Comprises drilling of boreholes to prescribed depths in rock, delivery of bolts and grouting mortar, all works in connection with installation of bolts and all deliveries in connection with construction of a reinforced concrete girder along the sheet pile wall as well as necessary formwork and measures for sealing against leakage of water and soils underneath the sheet pile footing before casting.
- b) The dimensions of the concrete girder and the concrete grade shall be specified in the special concrete specifications. Anchoring bolts as in specification 83.761.
- c) The bolts shall be fully grouted in rock. The holes shall be grouted by means of a hose from the bottom of the hole. Details regarding other parts of the working procedures shall be as specified in *the special specifications*.
- x) Quantity shall be measured as length of concrete girder along the centreline of sheet pile wall. Unit: m

83.763 Sealing behind concrete girder along sheet pile wall

- a) Comprises injection works in connection with located leakage zones along exposed sheet pile footings with a concrete girder.
- c) Injection shall take place before any blasting operations in front of the sheet pile wall. Boreholes shall be drilled at corners between the concrete girder and the sheet piles. Alternatively, boreholes may be drilled through the concrete girder down towards the sheet pile footing.

Standard injection cement shall be used and otherwise as specified in specification 83.7124 b).

The extent of the works shall be in agreement with the Project Owner.

- x) Quantity shall be measured as weight of cement grout without water. Unit: kg.

83.77 Grouted bolts in rock

83.771 Grouted bolts in rock above water

- a) Comprises installation of bolts/dowels in rock above the groundwater level or in a drained construction pit, see specification 81 a). See also specification 23.2.

The specification includes drilling of boreholes, complete cleaning and protection of holes, grouting of bolt holes, delivery and installation of bolts, bearing plates, anchoring or grouting of bolts and any tensioning as well as testing and documentation. Surveying work in connection with positioning and marking shall also be included.

Only grouted bolts are accepted as permanent bolts.

- b-c) Bolts of steel grade B500C shall be used in accordance with the requirements of NS 3576-3. Bolts shall be hot-galvanized and with at least 65 µm in accordance with NS-EN ISO 1461 and powder coated with epoxy in accordance with NS-EN 13438.

For grouted cam steel bolts mortar shall be used as grouting material. The mortar shall have a strength class of at least B20. The mortar shall contain expanding additives. Sand used in mortar shall have an even grain size gradation from 0 - 2 mm. Where water leakages occur in boreholes, rapid cement shall be applied.

The borehole dimensions shall be adjusted to the bolt type. For grouted bolts the difference between the nominal bolt diameter and minimum borehole diameter shall be adjusted to the bolt length, but not less than 10 mm. Bolts shall be completely surrounded by grouting mortar.

- x) Quantity shall be measured as number of bolts of each transverse dimension and length in rock. Unit: pcs

- 83.772 Grouted bolts in rock below water**
a-b) Comprises installation of bolts/dowels in rock. Otherwise as in specification 83.771
x) Quantity shall be measured as number of bolts of each transverse dimension and length in rock. Unit: pcs
- 83.8 Slurry trench walls**
a) Comprises all materials and works in connection with construction of complete slurry trench walls including rigging and excavation, slurry, establishment of footing, reinforcement, concrete etc. See the special construction specifications.
x) Quantity shall be measured as completed area of slurry trench wall. The height shall be measured from the bedrock or specified depth limit to the planned top level. The length shall be measured along the centreline of the wall. Unit: m²
- 83.81 Rigging and positioning of slurry trench walls**
x) Costs shall be given as a lump sum. Unit: LS
- 83.811 Rigging for slurry trench walls**
a) Comprises transportation, rigging and derigging of machines and equipment necessary for construction of slurry trench walls as described.
x) Costs shall be given as a lump sum. Unit: LS
- 83.812 Positioning and construction of slurry trench walls**
a) Comprises positioning, transfer and exact positioning of machines and equipment as well as all costs in connection with establishing a surveying basis for exact positioning of slurry trench walls.
x) Quantity shall be measured as numbers of continuous slurry trench walls. Unit: pcs
- 83.82 Excavations and slurry for slurry trench walls**
a) Comprises excavations for slurry trench walls as well as delivery of slurry and filling of trench.
x) As in specification 83.8. Unit: m²
- 83.83 Rock footing for slurry trench walls**
a) Comprises materials and works for construction of rock footing for slurry trench wall according to *the special specifications*.
x) Quantity shall be measured as planned length of rock footing along the centreline of the slurry trench wall. Unit: m²
- 83.84 Reinforcement for slurry trench wall**
a) Comprises delivery and all works in connection with construction of complete reinforcement as shown on the plans including delivery and allocation of accessories like spacers etc.
b) Reinforcing steel shall satisfy the requirements specified in specification 84.3. Reinforcing steel for reinforcement cages shall consist of weldable steel.
c) In the lower part of the reinforcement a grate shall be constructed to reduce the risk of uplift during the casting process.
x) Quantity shall be measured as net weight of construction reinforcement in accordance with bending lists based on nominal weights without additions for cut-off parts and waste, but with required lap lengths included. Assembling bars, reinforcement spacers and other aids shall be included in the reinforcement price. The same applies to additional lap lengths and bars the contractor wishes to use for practical reasons. Unit: ton
- 83.85 Concrete**
a) Comprises delivery and casting of concrete, successive removal of displaced slurry and removal or chiselling of inferior or surplus concrete. The specification covers up to 10% more concrete consumption than the theoretical volume. Concrete consumption over and above the additional 10% shall be covered by specification 83.86.
b-d) See *the special specifications* and specification 83.461.
x) Quantity shall be measured as completed volume of slurry trench wall with thickness equal to the theoretical thickness and height measured from the bedrock or specified depth limit to the planned top level. Length shall be measured along the planned centreline of the slurry trench wall. Unit: m³
- 83.86 Additional costs for extensive additional concrete consumption**
a) The specification shall be used if the concrete consumption exceeds 110% of the volume calculated according to specification 83.85.
x) Quantity shall be measured as volume used less 110% of the volume calculated according to specification 83.85 point x). Unit: m³

CONCRETE

- a-c) Comprises all materials and work involved in the production of structural components made of concrete. If the specifications are appropriate, they may also be used for structural components made of other materials.

In general, the Norwegian Standards for Concrete, i.e. NS 3473, NS 3465 (NS-EN 13670 when this has replaced NS 3465) and NS-EN 206-1, together with the complementary national standards as well as standards and publications referred to in these apply to the work in so far as no different instructions have been given in the specifications below.

The work shall be carried out in accordance with the rules that apply to the control class specified in accordance with NS 3473.

- d) The work shall be carried out within the geometric tolerances that are related to the safety and durability of the structure and also within the geometric tolerances that are related to the potential uses and appearance of the structure. The deviations allowed shall cover random variations resulting from production and shall not be systematically exploited. Independently of tolerances, emphasis shall be placed on the structure giving an attractive aesthetic impression. It is thus important that visible parts such as the superstructure have an even alignment without bends or depressions, and that columns are vertical. Visible concrete surfaces shall have a uniform appearance, be free of conspicuous holes, protruding lumps and nails and uneven edges, and they shall be free of disfiguring stains or discolorations caused by e.g. an interruption in casting, the uneven application of formwork lubricant or curing compound, insufficient insulation against cold, etc. Efforts shall be made to avoid discoloration from rusty water or uneven precipitation of lime deposits (efflorescence) due to exposure to rain shortly after the formwork has been removed.

The geometric tolerances that apply are given in Table 84-1. Unless otherwise specified in *the special specifications* Tolerance class 1 applies as specified in NS 3465 point 11.4, Fig. 1; point 11.5, Fig. 2; and Appendix F, Fig. F1d and e, F3a,b and d, F4b and F5.

The surface tolerances specified allow local deviations on a surface in relation to a base line or a base surface. A straightedge with knobs of equal height at each end and a measuring wedge are used to take measurements. The specified maximum surface deviation shall be understood as the maximum permitted deviation from the base line between the ends of the straightedge. The straightedge may be placed in any arbitrary direction, but account must be taken of any intended surface curvature when measurements are taken.

Joint reinforcement at transitions between structural components (e.g. from foundation to column) must be placed so that the tolerance requirements for both structural components are complied with.

The geometric tolerances do not include elastic deformations or effects of shrinkage and creep in the permanent structure. In the following, where geometric tolerances are specified as both an absolute and relative requirement (mm and %), the more stringent requirement of the two applies. The surface requirements are not applied to rough, concealed structural components such as large massive foundations below water or below ground. For requirements for overall structural tolerances for large foundations in deep water, see *the special specifications*. Overall structural tolerances specify the outer limits on the construction site that a point, a line or a surface must remain within. This means that each individual deviation, e.g. surveying deviations, dimensional variations, assembly variations etc. must remain within the specified allowable deviation, and that these are not allowed to add up in such a way that the overall deviation is greater than that allowed.

In addition, for the characteristic lines in the longitudinal direction of the structure and for the top level of the finished bridge deck, the deviation from the correct difference in height between two arbitrary points less than 20 metres apart shall not exceed the values given in Table 84-1.

Where the type of structure requires more stringent geometric tolerances (e.g. the overall structural tolerances for prefabricated elements), it is the contractor's responsibility to increase attention to accuracy so that the different structural components fit together.

Tolerance classes for individual structural components are given in Table 84-2. Unless otherwise mentioned in *the special specifications*, accuracy class B shall apply.

Tolerance class	1	2	3	4
Overall structural tolerance	±20 mm	±30 mm	±50 mm	±100 mm
Section, max. concrete	±10 mm	±15 mm	±20 mm	±30 mm
	±10%	±10%	±10%	±10%
Section, max. pre-stressed concrete	±10 mm	±15 mm	±20 mm	±30 mm
	±5%	±5%	±5%	±5%
Deviation from vertical, max.	20 mm	30 mm	40 mm	50 mm
	3‰	4‰	6‰	8‰
Surface deviations: depressions and bulges, ridges and peaks				
Measured length, 1 m	±3 mm	±5 mm	±8 mm	±12 mm
Measured length, 3 m	±5 mm	±8 mm	±12 mm	±20 mm
Max. deviation from correct height difference, measured within 20 m	±10 mm	±15 mm	±20 mm	±30 mm

Structural components	Accuracy class		
	A	B	C
Foundations	3	4	4
Abutments	2	3	4
Columns	1	2	3
Beams and crossbeams	2	3	3
Walls and bottom plate in the box section	1	2	3
Decks (lower edge, sides and sections)	2	2	3
Decks, surfaces that are to be asphalted	2	2	2
Decks, surfaces that are to be given an additional concrete layer	3	3	3
Characteristic lines along the structure's length (ledges, edges, breastwork etc.)	1	2	3

Tolerances for concrete surface courses are specified in specification 84.522, tolerances for asphalt surface courses in specification 87.1.

If surface requirements are not met, the surface shall be repaired by the contractor without compensation and in a manner that the Project Owner finds acceptable.

- e) Before the work begins, the contractor shall develop a template/framework for systematic internal quality control that he shall carry out and document in accordance with NS 3465. The template shall be filled in with specific quality control plans and checklists adapted to the type, size and inspection class of the work as the individual phases of the work are prepared. The template and detailed quality control plans shall be submitted to the Project Owner for comment.

Documentation of the contractor's systematic internal quality control as well as the concrete supplier's compliance control shall be compiled and submitted to the Project Owner each month unless otherwise agreed.

The Project Owner has the right to perform additional inspections and sampling for his own account, and is responsible for the independent quality check in the inspection class Extended Inspection. Tests of the compressive strength of the concrete, performed as part of the independent inspection, shall be evaluated in accordance with the rules for identity testing in NS-EN 206-1.

84.1 Scaffolding, temporary bracing and temporary cover

- a) Comprises all materials and work connected with the erection, maintenance and removal of special scaffolding and bracing that have a load-bearing or support function for vertical and/or horizontal loads on the structure or parts of the structure during the construction period, including their foundations. Also includes the maintenance and transport expenses that are not included in the formwork specifications as well as temporary cover.

With the exception of walkways along either side of the bridge deck, cf. specifications 84.131 and 84.141, necessary work and access scaffolding are not included in this specification. These shall be included in the price for the work concerned or for the rigging specifications.

Temporary roads and bridges are dealt with in Main Specification 1.

The contractor is responsible for planning the scaffolding and its foundations. Loads that are expected to be placed on permanent structural components shall be calculated and may be placed on them only if the structural components have the necessary bearing capacity. The plans shall be submitted to the Project Owner for comment well in advance of production.

If the method of building leads to extra loads or a need for bracing, additional reinforcement or an increase in dimension, the approval of the Project Owner shall be obtained well in advance and all extra expenses resulting from the construction method are considered to be included in this specification.

Scaffolding and bracing shall remain in place, bearing loads and preventing deformation, until the structure/structural component itself can support these loads without being damaged. For the stability of the structure and special structural components during construction, see *the special specifications* and/or the provisions of the contract.

- c) Scaffolding and bracing shall be planned and erected in accordance with current Norwegian Standards for the materials being used, as well as the Norwegian Labour Inspection Authority's rules and regulations.

Scaffolding and bracing shall be planned for the loads they will be subjected to (self weight, working load, live load, short-term load, concrete pressure etc.), and with enough stiffness in all directions that the given geometric tolerances for the finished structure are met. The scaffolding must be adjustable. The scaffolding and structures for adjusting height shall be designed in such a way that the static mode of operation is obvious, and in such a way that the deformations can be estimated. It must be possible to release the scaffolding and support from the structure slowly, without jolts or blows.

Deformations in the centring/support and scaffold foundation settlement when loaded shall be measured and compared with estimated/expected values. The results together with an evaluation are to be communicated to the Project Owner.

- d) Account must be taken of settlements, deflections etc. so that the tolerance requirements for the finished concrete structure, cf. specification 84, are met.
- x) The cost shall be given as a lump sum. Unit: LS

84.11 Foundations for scaffolding

- a) Comprises all materials and work associated with foundations for the scaffolding. Also includes removal of the foundation unless otherwise stated in *the special specifications*

To be used in connection with specifications 84.12-84.14, but not for specifications 84.15-84.18.

- c) Foundations shall be designed and constructed on the basis of assumed loads and actual ground conditions, and in accordance with any guidelines/information given in *the special specifications*. Reference is made especially to the danger of settlement due to insufficient consolidation, wash-out of materials under scaffold foundations, frost heave and thawing of frozen soils and penetration of pipes or other structures in the ground. The scaffolding shall be inspected and checked before it is loaded.

84.12 Bracing scaffolding for vertical and sloping structural components (pillars, columns, towers etc.)

- a) Comprises assembly of scaffolding, erected from the foundation on the ground for lateral support of high/slender or hinge-supported vertical structural elements as well as vertical and lateral support for diagonal structural elements until the structural component concerned can bear the load unsupported.

Temporary bracing until the structure is closed/stable is covered by specification 84.16.

84.13 Load-bearing scaffolding erected directly from the ground

- a) Comprises scaffolding erected directly from a foundation on the ground up to the formwork for structural elements.
- c) If the contractor wishes to use cantilever scaffolding the approval of the Project Owner must be obtained well in advance of erecting it out of a concern for possible needs for re-designing, calculations of super-elevation (camber), etc.

84.131 Load-bearing scaffolding erected directly from the ground for the bridge superstructure

- a) Comprises scaffolding erected from a foundation on the ground up to the formwork for the superstructure, including possible drive-through openings with a span of up to 6.0 m. For scaffolding where drive-through openings with a span of over 6.0 m are required, specification 84.14 shall be used.

The scaffolding shall be wide enough to accommodate walkways from which work can be carried out on both sides of the bridge deck. The walkways shall be included in the specification.

84.132 Load-bearing scaffolding erected directly from the ground for beams, bars, cantilevers etc.

- a) Comprises scaffolding erected from a foundation on the ground up to the formwork for beams, bars, cantilevers etc.

84.14 Cantilever scaffolding

84.141 Cantilever scaffolding for bridge superstructure

- a) Comprises fixed and travelling cantilever scaffolding excluding formwork for the bridge superstructure. Scaffolding with intermediate support is considered to be cantilevered when the respective spans exceed 6.0 m.

The scaffolding shall be wide enough to accommodate walkways from which work can be carried out on both sides of the bridge deck. The walkways shall be included in the specification.

The cantilever scaffolding shall be designed to accommodate the weight of the entire section of the superstructure unless otherwise stated in *the special specifications*.

- c) For the requirements for clearance height and width as well as possible requirements regarding the deformation allowable under loading, see *the special specifications*. Clearance height requirements must also be met when the scaffolding is fully loaded. The approval of the Project Owner for the use of intermediate support must be obtained well in advance.
- x) The quantity shall be measured as the surface that the scaffolding is to support, calculated as $bt \times L$, where
bt = the total width of the superstructure
L = the total length of the superstructure, measured as the length of the bridge deck for the finished bridge along the bridge centreline
Unit: m²

84.142 Cantilever scaffolding for beams, bars, cantilevers etc.

- a) Comprises fixed and travelling cantilever scaffolding excluding formwork for beams, bars, cantilevers etc.

84.15 Rigging/de-rigging of cantilever carriages

- a) Comprises transport to the construction site, rigging, any maintenance, and de-rigging of the number of cantilever carriages necessary to meet the deadlines specified. Operation/moving of the cantilever carriages is included in the unit price for formwork. The cost of any fixed scaffolding for the first cast section and extra costs in connection with the connecting section in the side span and main span shall be included in this specification.

Alternation/modification of formwork for balanced cantilever construction for adaptation to changes in the bridge's web or slab thickness shall be included in specification 84.2614.

Unless otherwise stated in *the special specifications*, the cantilever carriages shall be equipped with cover (walls and roof).

- c) The specifications for the assembly and operation of the cantilever carriages, i.e. section length, casting and tensioning procedures shall be given in *the special specifications*. The contractor shall assess the need for fixed scaffolding for the first section. It must be possible to readjust the carriage so that the entire dead load is borne by the carriage, also when parts of the section are allowed to be cast individually, unless otherwise stated in *the special specifications*.

If the contractor wishes to use a different element breakdown/approach from the one that is anticipated, this shall be submitted as an alternative tender. If an alternative method of execution is proposed after the contract has been signed, any supplements due to the changes shall not be borne by the Project Owner.

For each stage of the construction period, it shall be demonstrated that the concrete section at any point can bear the loads in question with the reinforcement that is tensioned. Unsymmetrical construction work is not allowed unless clearly stated in the plans. For symmetrical construction from the main columns, the section length and concreting procedures must be chosen such that neither the column nor the superstructure are subjected to tensile stresses greater than 1 MPa due to unsymmetrical temporary loads during construction. Capacity calculations shall be based on the strength the concrete has when the loads are applied to the structure. The superelevation calculation shall be based on an agreed construction plan. The contractor shall submit his detailed plans for the construction for comment well in advance, including information about loads (carriage weight, weight of materials and equipment that are stored in the carriage etc.), time lapse etc. The contractor shall not later depart from the agreed construction plan unless a new agreement has been made in this respect.

The design and strength of the cover (the carriage cleading) is the contractor's responsibility. For possible requirements concerning the strength of the cover, see *the special specifications*. The cover shall be fully rigged and functioning from and including the first cantilever section, so that formwork, reinforcement, concreting etc. can take place inside the cover irrespective of weather conditions. The cover shall not be moved until the concrete is poured and has cured sufficiently.

The cover shall have impervious walls and roof, however it may be adapted to the operational scheme, e.g. by adding openings in the roof and walls etc. so that transport of materials, concreting etc. can be performed with the least possible hindrances. The cover may not be moved in order to facilitate this work.

To avoid uneven loads and unanticipated deflections, it is very important that the weight of materials and equipment stored in and around the carriage must not deviate significantly from what has been agreed. Unless otherwise agreed, reinforcement for the next concreting section must be temporarily stored near a column, at least until the elevation for the next section has been fixed. When adjusting

the carriage, account shall be taken of the geometry and position of the cantilever arm at the time of measurement. Unless otherwise agreed, the carriages shall be dismantled and removed as soon as the cantilever arms are completed.

Before construction of the closure joints of the side spans and main span,

- The cantilever carriage that is used must have jacking equipment so that the cantilever arms are aligned with the bridge axis in all planes.

- The two cantilever arms are rigidly connected with each other, for example, by ensuring the carriage is rigidly connected with both end sections or by mounting stay bars, so that deformation cannot occur during concreting.

- The carriage shall be designed to resist all loads that could occur during the curing period (e.g. wind loads, temperature variations etc.)

84.16 Bracing of structure during the construction period

- a) Comprises temporary bracing of the structure until the closure joint forming a stable structure has been completed. See *the special specifications*.

Any foundations for bracings and their subsequent removal are included in the specification.

- c) The bracing can take the form of permanent scaffolding, stays, anchoring, additional reinforcement or an increase in the cross-sectional dimension on approval from the Project Owner.

- x) Unless otherwise indicated in *the special specifications*, the cost shall be given as a lump sum. Unit: LS

84.17 Temporary support, support columns

- a) Comprises temporary support and support columns including foundations, connection to the structure and later removal. See *the special specifications*.

- x) Unless otherwise stated in *the special specifications*, the cost shall be given as a lump sum. Unit: LS

84.18 Temporary cover (tent)

- a) Comprises all costs for temporary cover (tent) in places stated in *the special specifications*, to improve working conditions and protect against unfavourable weather conditions. Any strengthening of centring/support that might be necessary shall be included in the specification.

When cantilever carriages are used, temporary cover is included in specification 84.15.

- b-c) The design and strength of the cover are the responsibility of the contractor. The cover shall be erected and functioning irrespective of weather conditions when the work begins. The cover shall have impervious walls and roof and be adapted to the operational scheme, e.g. with respect to hatches and openings for material transport, concreting etc. Water shall be drained away from the external walls of the cover.

For the size of the cover, see *the special specifications*.

84.181 Procurement of temporary cover

- a) Comprises all costs involved in procuring and storage at the construction site of rigging for temporary cover (tent).

84.182 Assembly and operation of temporary cover

- a) Comprises all costs of assembly, operation, transfer, maintenance, de-rigging and removal of temporary covering.

- x) Quantity shall be measured as the area that is covered. Unit: m²

84.2 Formwork

- a) Comprises delivery, erection and stripping of the formwork with necessary support, bracing, shoring, shut offs, recesses, bevelling (chamfering), treatment of form tie holes etc. Covers complete formwork according to the geometry as shown on the drawings.

The following applies to the distribution among sub-specifications under 84.2:

- Sub-specifications under 84.21-84.25 and 84.28 cover the total formwork area with the exception of areas that are included in sub-specifications 84.253, 84.255, 84.2612, 84.273, 84.274, 84.275 og 84.276.
- Extra drawbacks and work beyond the formwork area itself in the form of the design and execution details for which separate sub-specifications are specified under 84.26 and 84.27 shall be included in the latter sub-specifications.
- Drawbacks and work associated with all other details shown on the drawings, but for which supplementary specifications are not specified under 84.26 or 84.27, are considered to be included in the sub-specifications 84.21-84.25 and 84.28 and their underlying sub-specifications.

Scaffolding, bracing and supports that are necessary to carry out formwork, rebar and concreting work, but which are not covered by separate specifications under 84.1, shall be regarded as included in the formwork specifications.

Bracing of cured structural components until a closed/stable structure is achieved, is included in specification 84.16.

If the Project Owner allows the contractor to use more construction joints than described/indicated in the plans, all costs for these are considered to be included in the formwork prices generally.

Slip forming shall not be used unless this is assumed in the production basis or has been accepted by the Project Owner. Slip forms shall be designed, constructed and checked as described in the Norwegian Concrete Association Publication no. 25.

- b) Metal formwork and formwork made of other good heat-conducting materials shall be insulated with at least 15 mm plywood during the cold part of the year.

For restrictions on the reuse of formwork materials, see *the special specifications*.

- c) Formwork shall be erected with the necessary superelevation. Account shall be taken of uneven settlement or displacement that results from the location of construction joints and deformations in the scaffolding, including their foundations.

When the formwork for post-tensioned concrete structures cannot be stripped before tensioning, the formwork shall be designed in such a way that it will not hinder the shape changes that the concrete is expected to undergo during tensioning

All protruding corners shall be chamfered with approx. 20 mm triangular chamfer strips unless otherwise specified in *the special specifications*.

At construction joints on visible surfaces, the joint groove shall as far as possible be placed in parallel with joints in the formwork. For horizontal construction joints, a chamfer strip shall be placed against the formwork. Before new pouring commences, the chamfer strip shall be removed, so that what is visible of the construction joint is just a straight line on the concrete surface.

At all construction joints, the formwork shall be designed to prevent seepage of cement slurry and mortar onto the section that has already been cast. The formwork ties shall be placed close to the construction joint and pulled tightly against it so that the concreting pressure does not result in leaks.

Cleaning

Before concreting, the formwork and construction joints shall be free of dirt, the remains of reinforcement tying wire and other foreign matter. Sufficient openings shall be made at low points to remove contaminants.

Bracing of formwork

Reciprocal bracing of the formwork walls shall be done with form ties through grey-coloured pipes of plastic or concrete. Ties etc. for visible surfaces shall be placed in a regular pattern.

Ties with cones shall be removed when the formwork is stripped. Unless otherwise stated in *the special specifications*, tie holes that are in the roadway splash zone, in structures in a maritime climate or in structural components less than 5 m from the ground surface are to be plugged with grey, sun- and weather-resistant plastic plugs from the outside. Visible abutments, retaining walls etc. are to be plugged with water-tight plugs on the soil side. Other stay holes can be left open.

Special permission must be obtained from the Project Owner to use formwork stays that are cut or screwed off within the finished surface, and where the holes are finished with mortar. The use of band iron or flat bar ties is not permitted in permanent structures.

For structural components that are assumed to be impervious to one-sided water pressure (e.g. caissons), ties with waterproofing shall be used.

Wooden materials may not be used for reciprocal bracing (spacers) between formwork walls. Wooden material may not be embedded in concrete.

Unless otherwise stated in *the special specifications*, all tie holes in the bridge decks shall be filled in with concrete. After removal of the casing, the hole shall be filled in along its entire length. In the overlap zone, top of the deck epoxy glue is used, before fresh concrete/mortar is glued to hardened concrete.

Stripping of formwork

The contractor shall ensure by means of compressive strength tests, temperature measurements or other means that the concrete has achieved sufficient compressive strength and stiffness, before the formwork is loosened. The most unfavourable places in the structure are to be used as a basis for evaluation.

For protection against exposure by delaying stripping, see specification 84.545. All formwork shall be stripped unless otherwise agreed.

- x) Quantity shall be measured as planned area of contact surface with concrete. For profiled or patterned concrete surfaces, the area is calculated from the projection of the contact area. Reductions in the surface area measured shall not be made for openings less than 0.5 m². Unit: m²

- 84.21 Plane formwork above water**
- a) Comprises plane formwork and formwork consisting of plane elements, as well as curved formwork with a curve radius of ≥ 200 m.
- The work is considered to be above water if the formwork in its entirety is above the water-table or in a dry construction pit, cf. specification 81 a).
Free choice of formwork surface (non-visible surfaces)
- b) The type of formwork surface is a matter of free choice.
- 84.212 Plane formwork with panels (visible surfaces)**
- b) Materials for the formwork surface shall be clean, undamaged, sharp-edged panels of even thickness. All panels shall be of the same type and material. One and the same surface shall be supported either with used panels only or with new panels only.
- c) The panels shall be placed in an orderly pattern. The pattern shall comply with any requirements in *the special specifications*.
- 84.213 Plane formwork with boards (visible surfaces)**
- b) Clean, undamaged, sharp-edged boards of even thickness and uniform width shall be used.
- As a general rule, formwork for the same surface shall be either with used of material only or of new material only. Formwork for reuse, e.g. balanced cantilever formwork and climbing formwork for columns/towers, can be constructed from new materials, (which become "used" as the work continues). Any departure from the general rule must be agreed with the Project Owner.
- Unless otherwise mentioned in *the special specifications*, the orientation of elongated structural elements (e.g., columns, beams, superstructure) shall be aligned with the main structural elements. For walls, the board orientation shall be indicated in *the special specifications*. The boards shall normally be placed with the rough side against the concrete. Any joints between the boards other than construction joints shall be distributed evenly over the surface.
- 84.214 Plane, profiled wooden formwork**
- b) Indentations in the concrete surface shall be made with milled, bevelled chamfer strips that can easily be stripped or with boards of varying thicknesses, cf. *the special specifications*.
- c) The boards/strips shall be laid in a regular pattern in accordance with *the special specifications*.
- 84.215 Plane formwork with patterned matrices**
- b) Matrices are to be used according to *the special specifications*.
- c) Joints, finishing against edges and corners etc., are to be produced according to *the special specifications*.
- 84.22 One-sided wall formwork above water**
- a) Comprises complete formwork including all supplementary materials and supplementary work that one-sided wall formwork entails, for example with respect to bracing and anchoring.
- By one-sided formwork is meant formwork where the concrete pressure is not balanced by a corresponding concrete pressure on the opposite formwork wall, but must be transferred by means of special stays anchored in rock, cured concrete, a dry wall etc., or by special support structures.
- The work is considered done above water if the formwork in its entirety is above the water-table or in a dry construction pit, cf. process 81 a).
- 84.221 One-sided wall formwork, free choice of formwork surface (non-visible surfaces)**
- b) As in specification 84.211.
- 84.222 One-sided wall formwork with panels (visible surfaces)**
- b-c) As in specification 84.212.
- 84.223 One-sided wall formwork with boards (visible surfaces)**
- b-c) As in specification 84.213.
- 84.224 One-sided wall formwork, profiled wooden formwork**
- b-c) As in specification 84.214.
- 84.225 One-sided wall formwork with patterned matrices**
- b-c) As in specification 84.215.
- 84.23 Curved formwork above water**
- a) Comprises complete curved formwork including all supplementary materials and supplementary work (e.g. special manufacture of formwork materials, special sawing of arched disks).

Arched formwork shall be considered curved when the formwork surface has a radius of curvature of less than 200 m. If arched formwork is allowed to be carried out as a polygon of formwork elements, it is considered to be plane formwork.

The work is considered to be carried out above water if the formwork in its entirety is above the water-table or in a dry construction pit, cf. specification 81 a).

84.231 Curved formwork, free choice of formwork surface (non-visible surfaces)

b-c) As in specification 84.211.

84.232 Curved formwork with panels (visible surfaces)

b-c) As in specification 84.212.

84.233 Curved formwork with boards (visible surfaces)

b) As in specification 84.213.

84.234 Curved, profiled wooden formwork

b-c) As in specification 84.214.

84.235 Curved formwork with patterned matrices

b-c) As in specification 84.215.

84.25 Special formwork

a-e) See *the special specifications*.

84.251 Double arched formwork

a-e) See *the special specifications*.

84.252 Permanent formwork

a) Comprises all materials and work in connection with formwork that is not to be removed, but will remain in the structure.

The special specifications will indicate whether ordinary formwork materials (panels or boards) can be used or whether rot-free or corrosion-proof materials, e.g. pressure impregnated boards, fibreglass-reinforced concrete plates (GRC), acid-resistant steel etc. must be used.

84.253 Formwork for cavities, voids, load-saving tubes etc.

a) Comprises delivery, forming and installation of light materials or elements as formwork for permanent cavities in the structure, as well as anchoring and joining these in accordance with *the special specifications*.

b) Type of material/type of load-saving tubes in accordance with *the special specifications*.

c) Light materials are to be placed closely together with no space in between. Load-saving tubes shall be sealed and stiff enough to prevent uncontrolled deformation. Splices in particular must be made with precision. Due to buoyancy effects during pouring, the materials/load-saving tubes must be firmly anchored. All cavities and load-saving tubes shall have drainage at the low points.

d) The location of the cavity shall not deviate anywhere from the theoretical location by more than 2% of the cross-sectional dimensions of the concrete at the place in question. The greatest allowable deviation is 20 mm. Requirements for reinforcement cover must be met.

x) Unless otherwise stated in *the special specifications*, quantities shall be calculated as linear metres of cavity per type and section design. Unit: m

84.254 Formwork for gaps (joint openings)

a) Comprises all materials and work related to formwork for joints with a gap width as specified in *the special specifications*. Also includes the removal of formwork materials, unless otherwise specified. Details in connection with joints in concrete are included in specification 84.85.

b) Gaps shall be lined with material that has sufficient strength and stiffness to tolerate concreting pressure and pressure from the reinforcement spacers. Expanded polystyrene may not be used as formwork for gaps ≥ 50 mm.

c) It must be ensured that the reinforcement receives the correct cover to the gap material and that reinforcement spacers, reinforcing bars etc. are not pressed into the gap material. Material in the gap shall be removed in such a way and using such means that neither the quality nor the appearance of the structural components is damaged.

d) The gap width shall not deviate more than 10% from the planned gap width; the maximum deviation permitted is 10 mm.

x) Quantity shall be measured as planned gap area, measured in the plane of the gap. Unit: m²

- 84.255 Formwork with prefabricated pipes**
- a) Comprises the delivery and assembly of prefabricated pipes as formwork. (Concrete poured on either the inside or the outside.)
- Circular recesses are covered in specification 84.275. Pipes for installations are covered in specification 87.5, Individual drainage pipes for surface water are included in specification 87.51.
- b-e) See *the special specifications*.
- x) Unless otherwise stated in *the special specifications*, quantity shall be measured in linear metres of pipe per type, dimension and section design. Unit: m
- 84.256 Formwork of prefabricated concrete elements**
- a) Comprises all materials and work to produce and assemble formwork of prefabricated concrete elements.
- b-c) See *the special specifications*.
- 84.257 Controlled permeability formwork**
- a) Comprises all materials and work for complete formwork of draining geotextile.
- b-c) Geotextile that has a documented drainage effect and that can be removed without damaging the concrete shall be used.
- The membrane shall be stretched onto the formwork in such a way that it does not form folds etc. during concreting. Unless documentation exists to show that the effect of the membrane is not reduced when it is used several times, the same membrane shall not be used more than twice (reuse once only). See also *the special specifications*.
- 84.26 Supplement for formwork for special structural details**
- a) Comprises any supplements required by the specified details, i.e. direct costs for executing the details and indirect costs for any operational delays, adaptation of other formwork etc. Unless otherwise specified, the formwork area shall be included in the formwork specification where the structural detail is covered.
- 84.261 Supplement for haunching, rebuilding of balanced cantilever formwork, brackets, consoles and slots**
- 84.2611 Supplement for anchor haunches/blisters on shuttered surfaces**
- a) Comprises haunches/blisters for anchoring post-tensioning reinforcement.
- x) Quantity shall be measured as number of haunches/blisters. Unit: pcs
- 84.2612 Anchor brackets on non-shuttered surfaces**
- a) Comprises brackets for anchoring prestressing tendons on non-shuttered surfaces, e.g. at the top of the lower plate for the box section. The brackets' formwork area is included in the specification.
- x) Quantity shall be measured as number of brackets. Unit: pcs
- 84.2613 Supplement for vaulting/haunches/blisters**
- a) Comprises vaults/haunches/blisters in locations and with dimensions as specified in *the special specifications*.
- x) Quantity shall be measured as the length of the vaults/haunches/blisters. Unit: m
- 84.2614 Supplement for modification of balanced cantilever formwork**
- a) Comprises supplements for modification of balanced cantilever formwork during construction as a result of abrupt or gradual changes in the thickness of the web plate or bridge slab structure.
- b-c) For the number of changes in web and bridge slab thicknesses, respectively, and the location of the change(s), see *the special specifications*.
- x) Quantity shall be measured as number of changes. Unit: pcs
- 84.2615 Supplement for spot consoles**
- x) Quantity shall be measured as number of consoles. Unit: pcs
- 84.2616 Supplement for continuous consoles**
- x) Quantity shall be measured as planned length. Unit: m
- 84.2617 Supplement for grooves**
- a) By groove is meant a long indentation in a concrete surface.
- x) Quantity shall be measured as planned length. Unit: m
- 84.262 Supplement for beams, transverse beams, pilasters etc.**

- 84.2621 Supplement for beams**
 x) Quantity shall be measured as planned length. Unit: m
- 84.2622 Supplement for transverse beams, transverse walls**
 x) Quantity shall be measured as number of transverse beams/walls. Unit: stk.
- 84.2623 Supplement for pilasters**
 a) By pilaster is meant a column that stands against and is cast monolithically with a wall.
 x) Quantity shall be measured as planned length. Unit: m
- 84.263 Supplement for side edges, sidewalk edges etc.**
 a) Comprises a supplement for formwork of longitudinal edges in accordance with *the special specifications*.
 c) The edge shall be shuttered and cast after the supporting structure has cured and the scaffolding is removed. The formwork shall follow the planned curvature of the bridge and even out any inaccuracies resulting from production of the bridge deck.
 d) Edges shall satisfy the tolerance requirements in specification 84 for the accuracy class that applies to the structure. The edges are to be considered as "characteristic lines in the longitudinal direction of the structure".
 x) Quantity shall be measured as planned length. Unit: m
- 84.264 Supplement for drip moulding**
 a) Comprises a supplement for drip moulding in accordance with *the special specifications*.
 x) Quantity shall be measured as planned length. Unit: m
- 84.27 Execution details**
 a) Comprises all costs entailed by more closely specified execution details.
- 84.271 Adaptation of formwork against rock above water**
 a) Comprises adaptation of formwork against rock or other irregular surface above the water-table or in a dry construction pit, cf. specification 81 a).
 x) Quantity shall be measured as planned length. Unit: m
- 84.272 Adaptation of formwork against rock below water**
 a) Comprises adaptation of formwork against rock or other irregular surfaces at or below the water-table, cf. specification 81 a).
 c) Formwork shall fit tightly against the rock or solid ground.
 x) Quantity shall be measured as planned length. Unit: m
- 84.273 Shuttered construction joints with continuous reinforcement**
 a) Comprises all materials and work in connection with formwork for planned construction joints with continuous reinforcement, including any bracing of protruding reinforcement, removal of formwork, cleaning wood chippings, cement slurry, the remains of curing compound etc. from the construction joint.
 Application of epoxy glue to the construction joint is included in specification 84.81, reinforcement splicing cassettes are included in specification 84.342.
 d) The position and direction of the reinforcement with respect to the construction joint shall be secured so that the reinforcement cover meets specifications.
 x) Quantity shall be measured as planned area of shuttered construction joint with continuous reinforcement. Unit: m²
- 84.274 Construction joints with shear keys**
 a) Comprises all materials and formwork in connection with formwork for construction joints with shear-key arrangements (notches) and continuous reinforcement, bracing of protruding reinforcement, removal of formwork, cleaning of wood chippings, cement slurry, the remains of curing compound etc. off the construction joint. Application of epoxy glue in the construction joints is included in specification 84.81.
 b) Unless otherwise stated in *the special specifications*, triangular chamfer strips 45-75 mm or 48×98 mm planks with bevelled edges shall be used.
 Unless otherwise stated in *the special specifications*, triangular chamfer strips shall be used for concrete thicknesses of up to 0.30 m; bevelled planks shall be used with concrete thicknesses of over 0.30 m. Triangular chamfer strips shall be placed close together. When planks are used for forming shear keys, a 48×98 mm plank is used for the first 0.30 m, thereafter a 48×98 plank for each 0.20 m concrete

thickness. Other methods that have been documented to give satisfactory shear effects can be used if approved by the Project Owner.

Unless otherwise stated, shear keys shall be arranged horizontally on the inside of the stop-end. Formwork oil which could reduce the adhesiveness of concrete cast next to it shall not be applied to shear keys. Shear keys shall not extend completely to the outside of the section so that they are visible. Longitudinal reinforcement shall be made continuous so that it has the full anchoring length in compliance with Norwegian Standards on both sides of the joint.

- x) Quantity shall be measured as planned surface contact area of the projected surface. (The height × width of the concrete section.) Unit: m²

84.275 Recesses

- a) Comprises materials and work to execute recesses with specified dimensions. Includes both the formwork area of the recess and the drawbacks recesses entail generally.

- x) Quantity shall be measured as planned number. Unit: pcs

84.276 Parapet recesses

- a) Comprises materials and work to execute recesses for parapet supports with dimensions and locations as specified in the engineering data. Includes the formwork area, drainage of recesses and the drawbacks the recesses entail generally.

For bridge parapets that are anchored in the structure in connection with the casting of recesses, parapet recesses are included in Specification 87.2 (wrong reference 86.3. in the Norwegian text)

Used only for special parapets that are intended to be anchored in recesses, or if bridge parapets anchored in recesses are considered to be a separate delivery not covered by the contract.

- x) Quantity shall be measured as planned number. Unit: pcs

84.28 Formwork below water

- a) Comprises all materials and work in connection with setting up and removing formwork of specified type, geometry and dimensions below water. All design and production details such as curvature, bracing of one-sided formwork etc. are considered to be included in the specification. Adaptation of formwork against the bottom is included in specification 84.272.

The formwork is considered to be constructed below water if it is below the water-table and the construction pit is not assumed to be dry, cf. specification 81 a).

For water depths, local conditions etc., see *the special specifications*.

- c) An overflow outlet is installed just above the water-line to release the water that is gradually displaced by the concrete. In other respects, the formwork shall be impermeable so that fresh or newly poured concrete is not washed out.

- x) Quantity shall be measured as planned contact surface area with concrete, cf. specification 84.2. Unit: m²

84.3 Reinforcement

- a) Comprises reinforcing steel and prestressing steel in concrete structures, while rock and soil anchors as well as rock bolts are included in specification 83.7. Dowels of smooth steel are included in specification 84.852. Drilling and grouting of dowels and splicing bars are included in specification 88.3245.

The rules below apply to specifications 84.31-84.35.

Comprises delivery, cutting, bending, installation and fixing of reinforcement, including all accessories such as mounting bars, spacers, tying wire, reinforcement spacers etc. for fully bound reinforcement. Includes all adaptation of reinforcement for ducts, pipes, embedded partss, rock etc.

- b-c) In general the provisions of the Norwegian Road Research Laboratory's Internal Report no. 1731 or new editions replacing it shall apply unless otherwise indicated below.

Ribbed reinforcing bars shall be of technical class B500NC in accordance with NS 3576-3. Documentation that the steel is of the quality specified and that the rolling mill is certified by an accredited technical inspection body for delivery of B500NC in accordance with NS 3576-3 shall be submitted to the Project Owner before any reinforcement is installed in permanent structural components.

Reinforcement shall be bent with the use of a mandrel in accordance with the rules in NS 3473. Reinforcement that has to be straightened or re-bent shall not have a temperature lower than 0°C. Reinforcement with a diameter of 16 mm or larger shall not be straightened or re-bent.

Unless otherwise stated, all splices shall be lap lengths.

With the exception of prefabricated reinforcement cages for structural components cast in water and for cast steel pipe piles, welding is permitted for assembly and bracing of reinforcement (tack welding) only after approval from the Project Owner in each individual case. The risk of fatigue fracture shall be assessed by the design engineer. Weld placement and design shall be planned by the contractor and execution shall be in accordance with the requirements in NS 3465.

d) The following deviations are permitted for cutting and bending of reinforcement:

- Bend measurement, $l < 1000$ mm: ± 5 mm
- Bend measurement, $l = 1001-2000$ mm: ± 10 mm
- Bend measurement, $l > 2000$ mm: ± 15 mm
- Compensation measurement (for free end): ± 25 mm

The compensation measurement relates to the free end of a reinforcing bar, where any cutting and bending measurement deviations are accumulated.

The finished concrete cover of the embedded reinforcement shall be as specified in the reinforcement drawings and within the given tolerances. Unless otherwise stated, the deviations permitted by the Norwegian Road Research Laboratory's Internal Report no. 1731 or new editions replacing it shall apply.

It shall not be possible to displace the centre of gravity of the combined reinforcement on the tension or compression side inwards from the concrete surface by more than 3% of the concrete section dimension, limited upwards to 10 mm.

Where it can be shown that reinforcement does not have the prescribed cover, the Project Owner can, if he finds it necessary, require that the surfaces be repaired at the contractor's expense.

The rules given in NS 3465 Figure 3c apply to tolerances for lap lengths.

x) Reinforcement is measured as the net quantity of constructive reinforcement according to bending schedules, on the basis of nominal weights, exclusive of supplements for stub ends and waste, but inclusive of necessary lap lengths. Installation bars, reinforcement spacers, chairs and other aids shall be considered included in the reinforcement price. The same applies to extra reinforcement joints and bars that the contractor wishes to use for practical reasons. Unit: ton

84.31 Ribbed reinforcing bars B500NC

- a) Comprises securely positioned ribbed reinforcing bars of steel class B500NC, in accordance with NS 3576-3, and a bar diameter as specified, exclusive of possible length supplements that are included in specification 84.351.
- x) As in specification 84.3. Nominal weights according to NS 3576-3. Unit: ton

84.311 Reinforcement B500NC, Ø 8

84.312 Reinforcement B500NC, Ø 10

84.313 Reinforcement B500NC, Ø 12

84.314 Reinforcement B500NC, Ø 16

84.315 Reinforcement B500NC, Ø 20

84.316 Reinforcement B500NC, Ø 25

84.317 Reinforcement B500NC, Ø 32

84.32 Reinforcement, special grades

84.322 Bi-steel

84.323 Reinforcement of stainless steel ribbed bars

- a) Comprises the reinforcement of ready bound stainless steel ribbed reinforcing bars, with bar diameter as specified and exclusive of any supplementary lengths that are included in specification 84.351.
- b-x) See *the special specifications*.

84.3231 Stainless steel reinforcement Ø 8

84.3232 Stainless steel reinforcement Ø 10

84.3233 Stainless steel reinforcement Ø 12

84.3234 Stainless steel reinforcement Ø 16

84.3235 Stainless steel reinforcement Ø 20

84.3236 Stainless steel reinforcement Ø 25

84.3237 Stainless steel reinforcement Ø 32

84.324 Reinforcement treated with corrosion protection

- a) Comprises securely positioned reinforcement treated with corrosion protection with a steel class, bar diameter and corrosion protection as specified in *the special specifications*. Cleaning of the steel and precautionary measures to prevent damage to the corrosion protection as well as damage repair are regarded as included.
- c) If epoxy-coated reinforcement is specified, it must be in accordance with NS 3574.

84.325 Fibre reinforcement

- a-x) See *the special specifications*. The unit price shall include all costs for the fibre reinforcement and its application, as well as all indirect costs in the event of changes in the concrete mix and execution as a result of the fibre additives. Unit: kg

- 84.326 Non-metallic reinforcement**
a-x) See *the special specifications*.
- 84.33 Welded reinforcement mesh and reinforcement units**
a) Comprises securely positioned reinforcement of welded reinforcement mesh and/or welded reinforcement units.
b-c) Any requirements relating to welded reinforcement mesh beyond what is usually supplied (NS 3476-4, technical class B500NA), shall be given in *the special specifications*. Unless otherwise stated, ribbed reinforcing bars, B500NC, in accordance with NS 3576-3 shall be used for reinforcement that has been welded together. See *the special specifications*.
x) Quantity shall be measured on the basis of theoretical weights. Unit: ton
- 84.331 Welded reinforcement mesh, regular mesh**
84.332 Welded reinforcement mesh, special mesh
84.333 Welded reinforcement beams
- 84.34 Special splicing devices for reinforcement**
a) Comprises delivery and installation of splicing devices for ordinary reinforcement.
b-x) See *the special specifications*. Unit: pcs
- 84.341 Mechanical couplers for mild reinforcement**
a) Comprises mechanical couplers with diameter and size as specified in *the special specifications*.
b) Until standards or European approvals for mechanical couplers come into force, the couplers shall have a documented failure capacity that is 30% higher than the nominal yield strength of the reinforcement that is to be spliced.
x) Quantity shall be measured as number of mechanical couplers. Unit: pcs
- 84.342 Reinforcement splicing cassettes**
a) Comprises cassettes for reinforcement splicing that is bent out after casting, of a type and size specified in *the special specifications*.
x) Quantity shall be measured as the planned length of the cassettes. Unit: m
- 84.35 Supplement for special solutions**
a) Comprises all supplements connected with more specialised deliveries or production in connection with ordinary reinforcement.

Welded special mesh is included in specification 84.33.

Special splicing devices are included in 84.34.
- 84.351 Additional length charge**
a) Comprises supplements to the basic price as a result of delivery/installation of reinforcing bars that are more than 12 m in length.
- 84.3511 Supplement for bar length 12-15 m**
84.3512 Supplement for bar length 15-18 m
84.3513 Supplement for bar length 18-24 m
- 84.352 Supplement for reinforcement below water**
a) Comprises all supplements relating to the installation of reinforcement in the prescribed manner below water.

The reinforcement is considered to be carried out below water if it is installed below the water surface and the construction pit is not assumed to be dry, cf. specification 81 a).
c) The reinforcement will as far as possible be installed in units (prefabricated reinforcement cages) on land. The units shall be braced in all planes to prevent displacement and deformation of the unit. The reinforcement cages shall be made of weldable steel.

The reinforcement connections are expected to be carried out by means of tack welding in accordance with the terms and conditions given in specification 84.3 c).
- 84.354 Earthing points for corrosion inspections**
a) Comprises the delivery and installation of earthing points for use in future inspections.
b) Unless otherwise stated in *the special specifications*, the earthing point shall consist of a 10 mm diameter screw socket of acid-resistant stainless steel with a length corresponding to the nominal concrete cover welded to a 10 mm diameter bar B500NC, length 0.5 m into a T-shape. After the formwork is removed, a 10 mm diameter bolt of acid proof stainless steel shall be placed in the earthing point so that it may be easily located.

- c) The screw socket is installed facing the formwork and the bar of B500NC is welded to the structural reinforcement. The earthing points are positioned as specified in *the special specifications*.
- x) Quantity shall be measured as number of earthing points. Unit: pcs

84.36 Free

84.37 Prestressing steel

- a) Comprises the delivery and installation of prestressing cables and strands, complete in the structure, including all necessary accessories, for example anchors using ancillary helical reinforcement, splice couplings, cable ducts with vents for evacuation of air and water, bracing plastic pipes, as well as tensioning, grouting work for the cable ducts, permanent corrosion protection of the anchors and if relevant temporary corrosion protection of the prestressing tendons. Also includes description/drawing of the characteristics/components of the tension system, tensioning data/instructions and grouting instructions. Also includes all materials and work for adaption of the formwork and ordinary reinforcement etc. that are a consequence of the prestressing tendons.

Prestressing bars and special prestressing steel types are included in specification 84.38. Anchoring in soils and rock is included in specification 83.7.

- b-c) Specifications given in Part A of the Norwegian Concrete Association Publication no. 14 apply, in addition to the requirements below.

The prestressing system shall be in accordance with European Technical Approval guidelines. Until such approvals are generally in place in the industry, the Project Owner can accept systems that can be documented to have been used in similar work previously.

Anchor plates that shall be corrosion protected by concrete topping shall be equipped with 4 threaded holes, M20 or larger, in which bolts or hooks are installed for anchoring the concrete topping.

The contractor shall, in collaboration with the prestressing steel supplier, draw up a detailed description of the anchoring, splice connections etc. The description shall be submitted to the Project Owner four (4) weeks at the latest before a final order for prestressing tendons must be made, unless otherwise stated in *the special specifications*.

The following data shall be sent to the Project Owner together with the description:

- Steel quality (Rp0.2 / Rm)
- Stress / strain diagram
- Relaxation (for 10000 hours)
- The elastic modulus of the cables, cross-section area (mm²), friction coefficient and expected incidental deviations of the cable ducts (radians/m)
- The lock loss of anchoring (mm)
- The diameter of cable ducts (mm), external and internal
- Space needed for jacks
- The anchoring dimensions and necessary concrete strength at tensioning

- e) Tensioning shall not be carried out before the concrete has a tested strength of at least 70% of the specified characteristic 28-day strength, but at least 32 MPa (cube strength), unless otherwise specified in *the special specifications*.

If the requirement for minimum concrete strength at tensioning for the prestressing system in question is higher than that specified above, the minimum required concrete strength at tensioning of the prestressing system shall be used. The concrete strength shall be checked at the most unfavourable location for curing and additionally just behind the anchor plates as described in the Norwegian Concrete Association Publication no. 14.

Irrespective of concrete strength, tendons shall not be fully tensioned earlier than 48 hours after the anchoring unit has been cast in concrete, unless otherwise stated in *the special specifications*. Step by step tensioning can normally be allowed according to agreement with the Project Owner. The concrete strength requirement in connection with prestressing shall be satisfied irrespective of the degree of prestressing.

The specified requirements for concrete strength apply to the entire cast section.

- x) Quantity shall be measured as:

$$f_y \cdot \sum_{i=1}^n L_i \cdot A_{si}$$

where:

- f_y is the guaranteed yield strength or 0.2 limit of the prestressing steel
- L_i is the length between the outer edges of the anchoring plates for each tendon.
- A_{si} is the theoretical cross section of each tendon.
- n is the number of tendons delivered.

Unit: mMN (metre Mega Newton).

84.371 Delivery and installation of prestressing tendons including accessories

- 84.3711 Delivery and installation of prestressing tendons**
- a) Comprises delivery, necessary transport and storage as well as complete installation of prestressing steel including cable ducts with air hoses and drainage.
- 84.3712 Active anchors**
- a) Comprises delivery and installation of anchors where the prestressing tendons are to be tensioned.
 - x) Quantity shall be measured as number of anchors. Unit: pcs
- 84.3713 Passive anchors**
- a) Comprises delivery and installation of anchors where tensioning of prestressing tendons is not to take place.
 - x) Quantity shall be measured as number of anchors. Unit: pcs
- 84.3714 Fixed splicing connections**
- a) Comprises delivery and installation of prestressing tendon splices including the necessary adaptation of formwork and ordinary reinforcement etc.

Includes anchors that have been embedded in cast section 1 and the splice that is to be embedded in section 2.
 - x) Quantity shall be measured as number of splice connections. Unit: pcs
- 84.3715 Movable splicing connections**
- a) Comprises delivery and installation of prestressing tendons connections for splicing two tendons so that the connection can move during tensioning. Includes the necessary adaptations to formwork and ordinary reinforcement etc.
 - x) Quantity shall be measured as number of joint connections. Unit: pcs
- 84.3716 Extra cable ducts**
- a) Comprises delivery and installation of extra cable ducts (spare) with grouting hoses, air hoses and drainage, fully installed in the structure. Grouting is included in specification 84.374.
 - x) Quantity shall be measured as planned length of cable duct. Unit: m
- 84.372 Tensioning of prestressing tendons**
- a) Comprises tensioning of prestressing tendons. Also includes preparation and submission of tensioning data/instructions.
 - x) Quantity shall be measured as the number of tensionings, i.e. the planned number of active anchors. If the contractor chooses to carry out tensioning in more steps than planned (e.g. as a result of restrictions with respect to full tensioning at an early concrete age) the costs of doing so are considered to be included in the unit price. Unit: pcs
- 84.3721 Tensioning in one step**
- x) Quantity shall be measured as number of tensionings, i.e. planned number of active anchorings. Unit: pcs
- 84.3722 Step by step tensioning**
- c) Tensioning shall take place as specified in the production specifications.
 - x) Quantity shall be measured as the planned number of tensionings. (Number of cables × number of steps per cable, i.e. number of times the jack is set up.) Unit: pcs
- 84.373 Temporary frost and corrosion protection for prestressing tendons**
- a-e) Comprises measures for temporary frost and corrosion protection as specified in *the special specifications*.
 - x) As in specification 84.374.
- 84.374 Grouting of ducts**
- a) Comprises all materials and work for grouting tension cable duct, including necessary preliminary and post-curing work.
 - b) Grouting shall satisfy the specifications in Norwegian Concrete Association Publication no. 14.
 - c) Before the structure is loaded, the grout must be checked to see it has sufficient strength. Grouting of cable ducts in free cantilever bridges shall, unless otherwise stated in *the special specifications*, take place at the latest for each 30 m (on each side) superstructure that is built.

If the structure during construction is designed as ungrouted according to recognised calculation methods, grouting can be delayed during the winter with the consent of the Project Owner.

If irregularities have occurred during grouting or if inspection of air vents, x-ray or ultrasound or other tests carried out after the mortar is cured result in suspicion that the cable duct has been insufficiently grouted, the Project Owner will, at the contractor's expense, require a closer inspection by e.g. drilling in suitable locations along the ducts concerned, as well as possible re-grouting.

- x) Quantity shall be measured as the sum of the lengths between anchor plates for each individual cable. Unit: m

84.375 Permanent corrosion protection of anchors

- a) Comprises all materials and work for final concrete casting or filling of recesses for anchors, i.e. formwork, reinforcement, concrete, bolts/hooks M20 or larger and if relevant epoxy resin.
- b-c) Unless otherwise stated in *the special specifications*, protection shall be carried out as described in Norwegian Concrete Association Publication no. 14, and bolts or hooks shall be installed in the 4 threaded holes of the anchor plate.
- x) Quantity shall be measured as number of corrosion protected anchors. Unit: pcs

84.38 Prestressing bars and special prestressing steel

- a-x) See *the special specifications*. Unit: m

84.4 Concreting

- a) Comprises delivery and casting of concrete including screeding and sealing of free (without formwork) concrete surfaces in accordance with the requirements for reinforcement cover. Protection measures against damage due to weather conditions (air temperature, wind, precipitation, sunshine, radiation loss against clear skies etc.) are included in the specification, beginning with and including transportation, temporary storage, pouring and screeding until the formwork can be removed and the structure can sustain the expected loads, or the curing measures specified are functioning. The usual winter measures to prevent frost damage and to ensure satisfactory curing in accordance with NS 3465 are thus among the measures that are included, as are costs involved in rescheduling concreting until the weather is more favourable.

The following are not included in this specification, but in specifications under 84.5:

- Further work on the concrete surface to comply with the tolerance requirements of specification 84.
- Measures to prevent cracking as a result of concrete shrinkage, curing heat etc. and the restraint to such volume changes that the structural design may achieve. (Cooling, heating, insulating, sectioning etc. to control temperatures during the early age of the concrete.)
- Cooling measures to avoid harmful high curing temperatures or to bring the concrete temperature down more rapidly to that of the surroundings.

Epoxy gluing in construction joints is included in specification 84.81.

- b) The concrete shall comply with NS-EN 206-1 and the specifications below. Concrete SV-40 and SV-30 shall correspond to durability class MF40, in exceptional cases M40. MF40 may always be used even if only M40 is required.

Concrete according to these specifications is "quality-defined concrete" in accordance with NS-EN 206-1. The specifications may not be changed according to the "equivalent concrete properties" method by either the contractor or the concrete supplier.

Component materials

Cement

Cement shall be of strength grade 42.5 or 52.5 and in accordance with the rules for durability class MF40 in NS-EN 206-1. Cement requiring little water and with moderate heat generation should preferably be chosen. Cement types that are not covered by Norwegian Standard rules may not be used without the written consent of the Project Owner. Applications for consent shall contain documentation of the composition and properties of the cement, and the consequences the cement will have for the concrete mix and concrete properties. Permission to use cement types with the additional designation RR (rapid cement) to achieve greater curing heat or higher early strength, must be obtained in each case, except for concrete for pre-fabricated concrete elements. For such use, the production methods used are assumed to allow for the risk such cement entails (difficult workability, rapid loss of workability, crack-inducing temperature gradients, greater curing stress etc.) so that the elements do not have thermal cracks or inferior casting. Sulphate-resistant cement (SR cement) shall only be used where it is specified.

Admixtures

Water reducing/plasticizing and/or super-plasticizing admixtures shall be used in all concrete. Admixtures other than air-entrainment agents, air-reducing agents, plasticizing/water reducing, super-plasticizing or retarding agents shall not be used unless specified by the Project Owner or after approval in the individual case.

Admixtures shall be selected with a view to good workability, sufficient workability time and air pore stability. The selected combination of admixtures shall be tested together with the cement to be used to ascertain air entrainment and the mixing time necessary to achieve full effect. The combination shall be documented to result in a finely distributed air pore system that gives the concrete good frost resistance, and is stable during transport and casting until the concrete has set. The quantity of plasticizing admixtures shall be sufficient to disperse all paste and fines, but not so large that the concrete compressibility, duration of workability or tendency to cracking/loss of plasticity is negatively influenced. The quantity of P-admixture (lignosulphonate with 40% dry matter) shall not exceed 0.8% of the cement weight. If necessary, the development of the mix design shall include full scale test mixes and test casting with alternative admixture products, combinations of dosages, in order to select the most suitable option.

Aggregate

If the use of aggregate formed by an industrial process is not specified, the aggregate shall consist of naturally impermeable and mechanically strong rock types. Aggregates that are used must have an even quality. Aggregate recovered from recycled concrete may not be used for concrete in strength class B35 or higher, or durability grade M45 or better.

The use of sea grabbed aggregate is prohibited.

In addition to the obligatory requirements set by NS-EN 206-1 and NS-EN 12620, the aggregate shall be in accordance with:

- Flakiness index for coarse aggregate: Category FI 35
- Fines content, coarse aggregate: Category f1.5
- Fines content, naturally graded 0/8 mm aggregate: Category f10
- Resistance to crushing for coarse aggregate: Category LA35
- Particle density: Requirements for the density of the concrete shall be met
- Water absorption, aggregate < 8 mm: max 1.5%
- Water absorption, aggregate > 8 mm: max 1.2%
- Resistance to freezing and thawing for coarse aggregate: Frost-proof
- Chlorine content: max 0.01 %
- Acid soluble sulphate: Category AS0.2
- Contaminants that affect setting and hardening:
 - * max reduction in 28-day compressive strength: 10%
 - * max change in setting time: 30 minutes
- Simplified petrographic analysis: Occurrence of pyrrhotite and iron pyrites in the aggregate shall be investigated and commented upon.

If there is a requirement in *the special specifications* concerning the E-modulus of the cured concrete, aggregate with a stiffness that meets this requirement shall be chosen. Compliance with specified requirements shall be documented by testing the concrete that it is intended will be used in the project.

The aggregate's greatest nominal particle size D_{max} shall be selected on the basis of the reinforcement density and other obstacles to pouring, but should not be smaller than 16 mm larger than 32 mm.
Mix water

Recycled wash water from concrete production may be used if it can be shown that it does not have a negative effect on the properties of the fresh or cured concrete. Seawater or other brackish water may not be used as mix water or for wet curing of concrete.

Concrete mix

General

The material composition shall be such that the specified strength class is complied with and the mix is also in accordance with the requirements that apply to the concrete specifications stipulated. The concrete quality is designated, e.g. B45 SV-40. The concrete specification is selected according to Handbook 185 Prosjekteringsregler for bruer [Design rules for bridges].

Table 84.4-1			
Concrete specification	Durability class NS-EN 206-1	Lower threshold value for cement content c kg/m ³	Threshold values for silica fume dosage % of cement for CEM I
SV-40	MF 40	350	4-6
SV-30	MF 40	350	8-11

When using CEM II/A-V cement in SV-40 and SV-30, the silica fume dosage shall constitute 3-5% of the cement.

The efficiency factor for silica fume is set at 2.0 in relation to both CEM I and CEM II for SV-40 and SV-30 concrete.

Density

Permission to use concrete with a de-moulding density of under 2300 kg/m³ or over 2500 kg/m³ must be obtained from the Project Owner due to the load considerations. The composition of the concrete (including air content) and density shall be submitted to the Project Owner as a basis for obtaining permission. The constraints on concrete density mean that not all aggregate defined as "normal-weight aggregate" in NS-EN 206-1 may be used in all cases.

Chloride content

The chloride content shall not exceed that of chloride class Cl 0.10. This applies to cement paste, mortar and concrete no matter the degree/type of reinforcement.

Concrete properties

Workability

Components, concrete mix design and consistency shall be chosen with a view to workability properties that ensure impermeable, homogeneous concreting. Concrete that shows destructive separation shall not be poured in the structure.

With the exception of intended variations in consistency due to special casting conditions, for example dense reinforcement or strongly inclined surfaces, the consistency on delivery of the concrete shall be kept constant for one and the same pour. For especially difficult concreting, use can be made of maximum stone sizes down to 16 mm, possibly a lesser amount of stones, or the concrete can be given a more fluid consistency by using super-plasticizing admixtures.

Self-compacting concrete, cf. Norwegian Concrete Association Publication no. 29, can be used if it is agreed with the Project Owner. When developing the mix design, it shall be documented by means of a test mix and property checks that the concrete is robustly enough proportioned to tolerate normal variations in components and measured quantities (e.g. water content $\pm 2.5\%$ of that prescribed) and still meet the set criteria without separating or losing flowability. A satisfactory reception system must be established at the construction site with qualified evaluation and checks of the concrete properties on site. Unless other criteria are set, whether in *the special specifications* or according to agreement with the Project Owner, the concrete shall meet requirements for both slump flow and spread time T500, and be without visible bleeding or slurry layers at the front of the pour. If satisfactory properties cannot be documented in any other way, T500 shall be more than 2 seconds.

On request, the contractor shall perform test pours using self-compacting concrete to document his skills, the concrete properties and results.

Frost resistance

Concrete for structural components that are exposed to freezing/thawing in moist conditions shall have an air-entraining admixture. All structural components that are exposed to de-icing salt or salt spray and salt mist shall be similarly treated.

If the frost resistance of the concrete cannot be documented in any other way acceptable to the Project Owner, the dosage of air-entraining agent shall be such that the air pore volume measured in the fresh concrete immediately before pouring (after any pumping) is:

5.0 \pm 1.5% for specified strength classes up to and including B 45,
3.5 \pm 1.5% for specified strength classes above B 45.

Concrete production

Mixing plant

The mixing plant shall be certified by an approved technical inspection body in accordance with NS-EN-206-1, in the inspection class specified. If the use of a mixing plant with the required certification entails an unreasonably long transport time, or other clear quality risks, the Project Owner may grant permission to use a mixing plant with certification in a lower inspection class for small projects. In such case, measures shall be agreed to document that all the quality requirements are met. Continuous mixing is not permitted.

The manufacturer shall have its own separate laboratory equipped and run in such a way that testing can take place in accordance with current Norwegian standards and described testing methods. For each individual mix, the weighing of components shall be controlled by the control system of the mixing plant so that the proportion of each ingredient and water/binder ratio are in accordance with the mix design within applicable tolerances.

All data for checking the composition of the concrete shall be available on request, either electronically or on paper.

The mix and transport capacity shall be sufficient to ensure that the structural components may be reliably cast at the prescribed pour rate and without unintentional construction joints or disfiguring lines on the surface where the pour front has been left undisturbed. Significant pauses in the delivery longer than agreed shall not occur.

Preliminary documentation

Before the concreting work starts, documentation of the concrete manufacturer's preliminary testing in accordance with NS-EN 206-1 shall be submitted to the Project Owner. Preparation of a new mix design by extrapolation of compressive strength, water/binder ratio or similar is not acceptable. If there are no empirical data from the previous 6 months for the range of concrete quality under the concrete production conditions and the concrete proportions in question, a lower value for the strength margins $f_{cm}-f_{ck}$ than 9 MPa (cube strength) shall not be assumed for 28 days concrete age when concrete production is to start.

In the inspection class "Extended inspection", the suitability of the concrete mix shall be verified with full scale mix(es) using the mixer and transport time that will actually be used. The change in consistency and air content in connection with transport to the construction site shall be documented. The Project Owner shall be notified within a reasonable period of time to enable him to observe the testing. The results of the testing, including the properties of the concrete in a fresh condition as well as the contractor's evaluation of its utilisation potential, shall be submitted to the Project Owner. Compliance of intended concrete mix designs with specified requirements shall be documented and submitted to the Project Owner for comment before casting of permanent structures can start.

If there are empirical data from the previous 6 months for use of concrete prepared with the same composition, components and mixing equipment for similar structures, and with similar transport distances, documentation for this concrete may be submitted to the Project Owner as an alternative.

Mix design changes

The Project Owner shall always be kept informed of what components (admixtures included) and which mix design is used. Changes in some of the components mean new preliminary testing and the results which must be submitted to the Project Owner before the change is made. Minor adjustments to the admixture doses to keep an even consistency and/or air content are not considered to be mix design changes.

- c) Concrete production shall be in accordance with NS 3465, supplemented by the specifications below. Concrete work shall be planned, directed and carried out professionally and taking account of the properties of the concrete in question in the fresh and cured stages, and of the current weather conditions. There shall always be a responsible work supervisor present during concreting.

Rigging and concreting plans

Both the concrete works in general and each individual pour shall be planned and prepared for with a large enough casting and compacting capacity for the pour to be carried out with a safe margin. When ordering concrete, the contractor shall, in addition to the basic requirements, specify the additional qualities for the fresh concrete that are necessary due to the method of production. Casting plans shall include reserve equipment (possibly also a reserve mixing plant) or other planned measures should any equipment fail. Casting shall not start until all rigging and all preparations have been completed. The Project Owner shall be kept informed of when the casting is to take place.

Casting

Before the casting starts, the form and construction joints shall be free of any foreign matter (sawdust, wood chips, pieces of tying wire, snow or ice etc.).

The concrete shall be handled in such a way that damaging separation is avoided. When self-compacting concrete is used, the danger of separation shall be especially monitored, cf. production rules for this type of concrete in Norwegian Concrete Association Publication no. 29. All pours of self-compacting concrete shall be specially planned on the basis of the concrete properties and production rules that apply to such concrete.

Furthermore, it must be ensured that concreting takes place continuously and without pause so that no disfiguring surface lines form. When poured from a height, the concrete must be ensured of free fall without separation due, for example, to hitting reinforcement. At the start of pours from heights, the concrete shall be fed through a stocking, concrete discharge pipe, pump hose etc., so that separation and stone accumulations are avoided. When there is narrow or inclined formwork, the concrete shall be fed through a stocking or pipe. For thick plates, walls and high beams, the concrete shall be laid in horizontal, even layers of a thickness adjusted to the geometry of the structure and the compactibility of the concrete. All concrete (with the exception of self-compacting concrete) shall be compacted by systematic vibration immediately after it has been placed in the form. Special emphasis shall be given to compacting against construction joints and between concrete layers. Compacting using a poker vibrator shall also take place when the surface is levelled with a screed vibrator. Concrete poured against cured concrete in vertical construction joints shall be vibrated for a minimum of ½ hour after it has been cast.

Casting shall be adapted to the tendency of the structure to develop cracks due to e.g. formwork deformation and settlement as well as due to creep and plastic deformations so that damage can be avoided. When walls and columns are cast, the vertical rate of casting shall be fast enough to avoid cold joints or disfiguring lines between the concrete layers, but slow enough so that settlement cracks do not occur. The upper 1-2 metres of walls/columns may if necessary be re-vibrated after the concrete has set, to avoid settlement cracks.

In connection with section transitions, there shall be a break in casting of a duration determined by the loss of consistency of the unpoured concrete, or it shall be re-vibrated to avoid settlement cracks. Final compaction and surface treatment of free (without formwork) surfaces shall be done after the concrete has finished its plastic settlement.

Structures that are exposed to soiling by concrete or cement water spatter shall be covered during pouring, or shall be cleaned immediately afterwards.

Construction joints

Cured concrete and splicing bars in construction joints must be cleansed of contaminants, loose material and anything else that may reduce bonding before more concrete is cast. When fresh concrete is cast, the surface against which it is being cast should contain no free water and should be dry.

Protection of cast concrete

Freshly cast concrete must be protected against harmful exposure to precipitation, cold, desiccation etc. Particular attention is drawn to the danger of frost damage and/or cracking in connection with cooling of the uncovered surface of thick decks and foundations, and the risk of cracking due to rapid cooling in the event of early formwork stripping.

Where there is risk of frost damage to freshly cast concrete near construction joints, insulating/heating measures must be taken to avoid frost in fresh/young concrete, and it must be demonstrated with the aid of temperature measurements that the concrete has the necessary curing temperature, so that the strength required for stripping, tensioning etc. is achieved.

Cast concrete must not be subjected to shocks (due to blasting, pile-driving, compression etc.) before the concrete has achieved the strength necessary to prevent damage.

Steps shall be taken to prevent oil spills and other contamination on the cured concrete.

Post-curing work

Any honeycomb or stone accumulations shall be chiselled clean down to solid concrete and repaired in a professional manner in accordance with the procedures that have been drawn up. The repairs must take place promptly, so that the patch and the underlying concrete can cure together. If necessary, steps must be taken to make operations independent of weather conditions while the repair is cured. On visible surfaces, the sides of chiselled out areas must be made as straight as possible, for example by sawing, where this is feasible.

Irregularities shall be removed from visible concrete surfaces. Protruding nails must be removed from all surfaces that are not to be covered immediately after stripping of formwork.

Detrimental cracks due to workmanship shall be repaired free of cost to the Project Owner. The following crack types are normally regarded as detrimental:

- throughgoing, water-bearing cracks irrespective of width
- cracks up to and along reinforcing rods
- cracks of over 0.35 mm in the concrete surface that extend to the reinforcement

- e) Strength tests shall consist of at least two samples tested at the same age.

Assessment of test results

Each test result shall be assessed as soon as it is available with respect to compliance with specifications, rejection of concrete or correction of production. The results of the compliance tests must be set up separately for each concrete specification/strength class. SV-40 and SV-30 shall not be included in any concrete family, but their conformity can be assessed together with other MF 40 concrete produced according to the same mix designs. Different mix designs within the same specification (e.g. B45 SV-40) can be included in the same conformity assessment.

The comparison shall be accompanied by an assessment of whether the results are satisfactory or whether they require that production must be corrected.

Compliance testing

At the start of production with a mix design of which there has been no experience in the last 6 months, compliance testing shall start with three samples from the first 50 m³, and then the rules for "initial production" shall be followed.

If it is found and documented that the air content of the concrete is virtually unchanged from the production site to the delivery site, the compliance test can be carried out at the production site. If it is not documented that the air content remains virtually unchanged with transport, the compliance test of the air content shall be carried out on samples taken at the delivery site, after transport to the construction site and after any adjustment with additives. If the concrete is pumped, tests shall be taken after pumping where possible. If the air content increases with transport, samples for compliance testing of strength shall also be taken at the construction site.

As part of production control of concrete with requirements relating to air content, the air content shall always be checked daily when pouring starts, and after a change in the quantity of air-entrainment agents. The air content of samples to be cast for strength testing shall also be tested.

Identity testing

For particularly stressed structural components such as cantilever arms for free cantilever bridges, columns etc., strength shall be determined through identity tests on the construction site on at least one sample, normally three samples, per cast section. The air content shall always be tested. on samples to be cast for strength testing

On the construction site, air content shall always be tested daily when concreting starts, and in the case of continuous concreting, at least every third hour, or at least once every 50 m³ or part thereof. If the air content increases with transport to the construction site, air content testing shall take place twice as frequently.

Consistency (slump test, flow table test etc.) is measured as needed to check workability and/or loss of workability. When self-compacting concrete is used, the slump flow and T500 time shall always be measured at the start of casting.

During the cold season and during particularly hot weather, the temperature of the fresh concrete on the construction site must be measured at least as frequently as the air content.

Water/binder ratio, mix design compliance

Unless otherwise agreed, for every 500 m³ or part thereof a table shall be set up of measurement accuracy/design compliance and the water/binder ratio achieved on the basis of the batch weight data of the components going into the mixer and measurements of the aggregate's moisture content. Each table shall consist of at least 10 sets of weighing data. The effective water/binder ratio shall be calculated on the basis of measured values of the water absorption of the aggregate. If the measurements (actual and desired values) and other variables for testing of design compliance and w/c ratio are printed on the delivery tickets of the mixer's control system, the frequency of these overviews can be reduced to one for every 2000 m³ or part thereof.

Every 1000 m³ or part thereof, the water/binder ratio determined on the basis of the weighing data of the mixer shall be verified by at least 5 independent measurements according to a recognised method. The measuring method may determine the water/binder ratio directly, or it may determine the water content of the concrete by drying in a microwave oven or similar method. Individual samples for testing shall be representative samples of various concrete loads/batches taken on the construction site. The water/binder ratios determined on the basis of the weighing data and by verification method, respectively, shall be compared. In the assessment, account shall be taken of the accuracy of both methods.

If the batch weight data and/or water/binder ratio are not in compliance with the mix design, the cause of the non-compliance shall be established and correction shall take place.

- x) Quantity shall be measured as net planned volume according to drawings without deduction of volume for reinforcing bars, cable ducts and embedded parts. When concrete is to be cast against rock, and the surface level of the rock before blasting is not as expected, volume is calculated according to drawings with a corrected level for the lower edge of the foundation. No additional amount shall be paid for any larger concrete quantities due to inaccurate excavation or blasting. If formwork with an irregular surface is planned (e.g. sheet pile wall, irregular contours etc.) all concrete that will be in contact with the formwork shall be included in the planned volume. Unit: m³

84.41 Concreting above water, normal-weight concrete

- a) Includes delivery, casting and screeding of concrete, curing measures and protection of concrete against harmful influences plus patching and finishing work.

Finishing work other than this is covered by specifications 84.54 and 84.55.

Concreting is regarded as being carried out above water if the work is carried out above the water table or in a dry construction pit (see specification 81 a).

- b) Requirements regarding strength class and concrete specifications shall be indicated in *the special specifications*.

84.411 Leveling with concrete on soil

- b) Concrete quality of at least B30 m60 pursuant to NS-EN 206-1.
- c) The entire foundation contact area and a minimum distance of 150 mm beyond this area shall be levelled with concrete. The thickness shall not be less than 50 mm anywhere, unless otherwise indicated in *the special specifications*. The screeding precision shall be such that the requirements for safe covering of the reinforcing in the foundation are clearly fulfilled.
- x) Quantity shall be measured as net planned area including the area up to 150 mm beyond the contact area of the foundation. Unit: m²

84.413 Concrete SV-40

84.4131 Concrete B35 SV-40

- 84.4132 Concrete B45 SV-40
- 84.4133 Concrete B55 SV-40
- 84.4134 Concrete B65 SV-40
- 84.414 Concrete SV-30
- 84.4141 Concrete B35 SV-30
- 84.4142 Concrete B45 SV-30
- 84.4143 Concrete B55 SV-30
- 84.4144 Concrete B65 SV-30

84.415 Ballast concrete, non-structural concrete

- b) Requirements regarding strength class do not apply to ballast concrete unless otherwise specified in *the special specifications*. Chloride class Cl 0,10 applies.

84.416 Concreting above water with special concrete

84.42 Concreting above water, lightweight aggregate concrete

- a) Includes delivery, casting and screeding of concrete, curing measures and protection of concrete against harmful influences plus patching and finishing work.

Finishing work other than this is covered by specifications 84.54 and 84.55.

Concreting is regarded as being carried out above water if the work is carried out above the water table or in a dry construction pit (see specification 81 a).

- b-c) Preliminary documentation, production and execution shall be in accordance with NS-EN 206-1, Norwegian Concrete Association Publication no. 22 (Norwegian text) and *the special specifications*.

84.421 Cement-stabilized material with lightweight aggregate, min. LB12

- 84.422 Lightweight concrete SV-40
- 84.4221 Lightweight concrete LB35 SV-40
- 84.4222 Lightweight concrete LB45 SV-40
- 84.4223 Lightweight concrete LB55 SV-40
- 84.423 Lightweight concrete SV-30
- 84.4231 Lightweight concrete LB35 SV-30
- 84.4232 Lightweight concrete LB45 SV-30
- 84.4233 Lightweight concrete LB55 SV-30

84.43 Underwater casting

- a) Covers all costs associated with delivery, casting and screeding of concrete under water, protection of the concrete against harmful influences and the special planning, inspection and documentation of the work as prescribed.

Concreting is regarded as being carried out under water if the work is carried out either below the water table or in a construction pit that is not expected to be dry (see specification 81 a).

For water depths, local conditions etc., special workability requirements for concrete containing anti-washout admixtures, and special requirements concerning overall building tolerance, diving inspections, homogeneity checks and in situ strength checks, see *the special specifications*.

- b-e) Materials, production and inspection of concrete works in water shall be in accordance with Norwegian Concrete Association Publication no. 5 "Guidelines for design and production of concrete structures in water" Part A (Norwegian text) and *the special specifications*.

84.431 Underwater casting with concrete containing anti-washout admixtures

- b) Unless otherwise specified in *the special specifications*, concrete type B35 M40 shall be used, with composition and properties as described in Norwegian Concrete Association Publication no. 5.
- x) As in specification 84.4. As with other concrete, losses due to the impossibility of completely emptying mixers, transportation equipment etc. shall be calculated into unit prices. Unit: m³

84.432 Underwater casting with normal-weight concrete

- b) By "normal-weight concrete" is meant the concept as defined in Norwegian Concrete Association Publication no. 5. Unless otherwise specified in *the special specifications*, concrete types B45 M40 and/or MF40 shall be used, with composition and properties as described in Norwegian Concrete Association Publication no. 5. Normal-weight concrete shall be used in the whole structural component or cast wet-on-wet with concrete containing anti-washout admixtures.

84.433 Underwater inspection of construction pit

- a) Comprises underwater inspection with documentation of foundation conditions, after preparation of the construction pit (complete excavation, if relevant blasting and scaling), before concreting starts.

Profiling of the base with depth measurement before excavation, before blasting and after scaling form part of the ordinary surveying work (see Main Specification 1).

- c) Rock quality and any cracks shall be mapped. Low points/depressions and rock slopes shall be registered. The inspection shall be documented by means of a separate report, which shall contain photographs as a minimum. Video clips may also be used.
- x) Quantity shall be measured as the number of inspected and documented construction pits (axes). Unit: no. (of inspections).

84.434 Underwater inspection of cast concrete surfaces

- a) Comprises underwater inspection with documentation of all concrete surfaces after stripping of formwork.

- c) All cast concrete surfaces shall be inspected for honeycomb formation. In particular, at the base of pillars and walls and construction joints shall be examined for possible casting defects and honeycomb formation. Any area where mud pockets or similar are suspected should be inspected further with suitable equipment. The inspection shall be documented with a separate report, which shall as a minimum contain photographs and location specifications for all observations. Video clips may also be used.

- x) Quantity shall be measured as the number of inspected and documented structural components (axes). Unit: no. (of components inspected).

84.435 Supplementary underwater inspections

- a) Comprises underwater inspection with documentation as specified in *the special specifications*. Supplementary underwater inspections shall be ordered by the Project Owner in the individual case.

- x) Quantity shall be measured as the number of completed and documented underwater inspections. Unit: no. (of inspections).

84.436 Homogeneity and casting inspection

- a) Comprises all costs of documenting the placement/homogeneity of concrete cast under water. The documentation shall be obtained by taking, logging and assessing core samples. The specification does not include costs that are covered by the specifications:

82.42 Coring of rock and concrete

84.438 Casings for coring of concrete cast under water

Homogeneity and placement inspection shall only be carried out for structural components for which it has been ordered by the Project Owner.

- c) For the scope and details of the execution of the inspection, see *the special specifications*.

Unless otherwise indicated in *the special specifications*, core samples shall have a diameter of at least 40 mm. A continuous coring may have a depth of up to 3 m. Bored holes shall be completely refilled with suitable grout.

- x) Quantity shall be measured as the number of inspected structural components. Unit: no. (of inspected components).

84.437 Strength check of concrete cast underwater

- a) Comprises all costs of documenting the in situ strength of concrete cast under water. The documentation shall be obtained by extracting, forming and compression testing core samples. The specification does not include costs that are covered by the specifications:

82.42 Coring in rock and concrete

84.438 Casings for coring of concrete cast under water

The specification also includes assessing and reporting on the homogeneity of the concrete, unless otherwise indicated in *the special specifications*.

Strength checking with core samples shall only be carried out for structural components for which it has been ordered by the Project Owner.

- c) For the location, depth and scope of coring/sampling see *the special specifications*. The diameter of the core samples shall be chosen on the basis of the maximum particle size of the concrete, and shall not be less than 75 mm. Bored holes shall be completely refilled with suitable grout. Preparation of samples and testing shall be carried out as specified in Norwegian Standards.

- x) Quantity shall be measured as number of strength tests consisting of two test pieces prepared from core samples. Unit: no. (of strength tests).

84.438 Casings for coring of concrete cast under water

- a) Comprises delivery and assembly of casings for deep coring of structural components cast under water, and refilling with suitable grout.

For length, placing etc. of casing, see *the special specifications*.

- b) The casings must be of steel, and of a strength and rigidity that enables them to sustain the pressure of the concrete during pouring.

Grout for refilling of casings must have a strength at least equivalent to the strength class described for the structural component.

- c) Casings must be installed in such a way that they cannot be displaced when casting takes place around the casings.

- x) Quantity shall be measured as the planned length of casings. Unit: m

84.44 Concrete surface course

- a) Comprises all materials and works for complete production of a concrete surface course. Structural bridge decks are covered by specification 84.41 or 84.42. The specification includes all costs that are not calculated into the following specifications:

84.18 Temporary cover (tents)
84.3 Reinforcement (normally specification 84.325 Fibre reinforcement).
84.522 Screeding and treatment of concrete surface course
84.54 Curing measures
87.3 Bridge supports and bridge joints
87.4 Joint structures
87.18 Expansion joint thresholds

- e) After a minimum of 7 days' curing, the surface course must be inspected for evenness, cracks and delamination.

- x) Quantity shall be measured as planned surface course area. Additional material to level off irregularities in the surface of the base layer and extra work with joints, bridge edges and construction joints/day joints shall be included in the price. Unit: m²

84.441 Monolithic concrete surface course

- a) Comprises delivery and casting of surface course concrete as indicated in *the special specifications*.

- b) Unless otherwise specified in *the special specifications*, the same concrete quality shall be used as in the structural bridge deck

Unless a particular type of surface course concrete is specified, the surface course shall be cast together with the structural bridge deck by pouring a thicker cover over upper reinforcing bars.

If a particular surface course concrete is specified, this shall be cast wet-on-wet on the base concrete. The thickness of the surface course concrete shall be at least equal to the specified surface course thickness. Surface course and base concrete shall be vibrated well together.

- c) The surface of the monolithic concrete surface course shall be grooved across the driving direction. The grooving shall be carried out immediately behind the screed vibrator and followed immediately by application of curing agent.

- e) Before pouring, the upper reinforcement layer shall be checked carefully with respect to location (height), securing (any loose rods) and protruding individual rods.

84.442 Topping on concrete surface course

- a) As in specification 84.44.

The specification also includes all costs that are not calculated into:

84.6 Mechanical treatment of cured concrete (normally specification 84.62 or 84.63)
84.8 Gluing, surface treatment and accessories (normally specifications 84.811 and 84.82).

- b) Unless otherwise specified, B55 SV-40 shall be used with a steel fibre quantity of 40 kg/m³ of 30 mm long fibres. The concrete mix must be specially proportioned for wearing strength and contain as much aggregate as it is possible to achieve a impervious cast with.

The maximum nominal grain size D_{max} of the aggregate in concrete topping shall be 16 mm, or in the range 16 – 20 mm. Aggregate for the concrete surface course shall generally be of mechanically hard, tough and hard-wearing rock, and shall in addition to the requirements in specification 84.4 satisfy Nordic abrasion value class AN14 (cf. NS-EN 12620).

The grain size distribution of the aggregate shall be even, without abrupt changes, and the particle shape shall be favourable with respect to water requirements and use of the largest possible proportion of aggregate in the concrete. The aggregate shall not have smooth surfaces or coatings that reduce the adhesiveness of the cement glue. The coarse aggregate shall also satisfy the requirements regarding aggregate for concrete pavements in Handbook 018 "Road construction".

Concrete mix, fibre type, epoxy glue, latex product for the slurry and if relevant joint filler shall be submitted to the Project Owner for comment.

- c) Increasing the thickness of the concrete over large areas in order to even out lengthwise depressions must be agreed in each individual case.

Pre-treatment of concrete pavement on which pouring is to take place shall consist of cleaning of the surface of the pavement and repair of local defects such as cracks, casting defects and unevenness in excess of the permitted deviations. Pre-treatment shall include all surfaces the cast concrete will come into contact with, including the side surface of edge beams and vertical construction joints in the topping itself.

The cleaned bridge deck shall be inspected by the contractor's inspection manager and the Project Owner's independent inspector before pouring can start.

The surface of the underlying concrete with mass ratio $m \leq 0.4$ and silica fume content should be dry, and must not be moistened in advance by watering. If epoxy glue is used, the surface of the structural concrete should be light grey when dry, if necessary through artificial desiccation. Longitudinal construction joints and screed guides must not be located in wheel I areas.

All vertical construction joints and 30 cm wide longitudinal strips and 50 cm wide transverse strips along the edge of each cast section shall be glued with epoxy as described in specification 84.811. Brush-coating with cement slurry containing latex, as described in specification 84.82 shall be used for the area within the strips of epoxy glue.

If a screed vibrator is used, the concrete topping must be compacted with a poker vibrator before screeding. The vibration must be carried out with closely spaced immersion points to bring about homogeneous, solid contact with the base layer. It is particularly important that a poker vibrator be used along the screed guides / lateral shuttering.

Permanent bridge joints shall be covered with stiff materials, so that the concrete overlay can be made continuous across the joint. The concrete over the joint shall be removed within two hours of pouring. After the concrete has cured, an accurately positioned recess shall be sawn for the joint.

84.45 Prepect concrete

- a-x) See *the special specifications*. Unit: m³

84.46 Sprayed concrete

- a) Comprises cleaning of the base, delivery and application of sprayed concrete, and all patching and finishing work.

- b-x) See specification 33.4 and *the special specifications*. Unit: m³

84.5 Treatment of fresh and curing concrete

- a) The specification describes measures that in terms of production form part of specification 84.4, and must be read in conjunction with specification 84.4. Comprises surface treatment of fresh concrete to achieve a particular surface structure and/or compliance with tolerance requirements specified in specification 84 or *the special specifications*.

It also covers curing measures (including use of curing compound) and measures to prevent undesirable effects due to of the concrete's curing heat (e.g. special covering/insulation, cooling of fresh concrete, cooling of curing concrete with embedded cooling pipes, heating up of cured concrete with heating cables etc.)

These measures are carried out at the time that yields the best result.

- x) Quantity shall be measured as planned area. Unit: m²

84.51 Screeding and trimming of concrete surface

- a) Comprises final surface treatment in terms of sealing and smoothing of the concrete surface beyond what is covered by specification 84.4.

Screeding of bridge decks is covered by specification 84.52.

- c) The concrete surface shall be levelled with a straightedge or similar and worked with a wooden board or similar to eliminate pits in which water can accumulate. In addition the surface shall be steel-trowelled if this is specified in *the special specifications*.

- e) The surface shall satisfy the same tolerance class as the structural concrete generally (see specification 84).

Emphasis must be placed on giving side edges /edge beams an attractive appearance in the form of "characteristic lines in the longitudinal direction of the structure" (see Specifications 84).

84.52 Screeding and finishing of bridge deck

- a) Comprises the screeding and surface finishing necessary to meet the specifications.

- b) Surfaces that do not meet the specifications shall be repaired with materials and methods accepted by the Project Owner.

- c) The deck casting shall be planned and executed with a view to providing the best possible surface as a base for the surface course. Special features that shall receive special emphasis are lack of cracking, evenness and surface structure.

If no other method is accepted, or required by the Project Owner in *the special specifications*, the concrete at the surface shall be compacted and levelled by means of a screeding vibrator beam/bridge resting on fixed, solidly supported screed guide rails whose lower edge is above the completed concrete deck (air guides).

The screed rails shall have a rigidity adjusted to the tolerance specifications, the loading due to the screeding equipment and the distance between the supports.

The strength of the vibrator and the vibration time must be adjusted such that the top layer is completely compacted, without unnecessary cement slurry being drawn up to the surface. For thick decks, the screed rail heights must be checked and if necessary adjusted before screeding, but after the bulk of the concrete has been cast. Surface evenness must be checked with a straightedge immediately after screeding, so that any defects can be repaired immediately. All grooves and irregularities must be smoothed out.

If the process takes place in the winter, spring or autumn, the concrete surface must be protected against frost damage. In the event of thick bridge deck slabs and weather conditions that imply a risk of crack-generating temperature gradients, the concrete surface shall also be protected with suitable cover, heating insulation etc. The protection shall remain in place until the risk of temperature cracking is over.

If the surface requirements are not satisfied, the contractor undertakes to make repairs for his own account in a manner that is accepted by the Project Owner.

Defects in the concrete and nonconformities in the reinforcement cover shall be repaired.

Minor casting defects and depressions may be repaired with cement-based grout glued to the base with epoxy glue or with epoxy grout which after placement is strewn with a layer of dry, dust-free sand. The thickness of the epoxy grout shall not exceed approximately 20 mm. The same type of epoxy glue shall be used for priming and grout. Sand quality and quantity and the grain size distribution of the aggregate in the grout and for strewing shall be in accordance with the epoxy supplier's specifications. Major cast flaws or defects must be chiselled out and filled with cement-based grout or concrete which is glued to the base with epoxy glue. Patching with cement-based material must be given appropriate curing conditions and protected against too rapid dehydration.

Exposed reinforcement shall be cleaned by blast cleaning. All loose material shall be removed with water- and oil-free compressed air. Epoxy primer shall then be applied and the reinforcement protected with a layer about 5 mm thick of epoxy filler. Reinforcement with substandard cover shall be given supplementary protection with epoxy filler or epoxy impregnation of the concrete. Epoxy-treated surface shall be topped with dry, dust-free sand. After curing, all loose material shall be removed to ensure adhesion of further pavement layers.

Cracks and fissures in bridge decks must be patched with low-viscosity epoxy even if separate waterproofing is to be applied.

- e) Before concreting starts, the vibrator equipment fitted with a chamfer strip equivalent to the minimum thickness of the cover plus any surface course shall be drawn over the screeding rails to check that the minimum thickness will be achieved. It must also be checked that the reinforcement is secured in a fixed position and that there are no individual protruding bars.

To document correspondence with the geometrical tolerances, the contractor shall carry out geometric checking of the screeded bridge deck, once before stripping of the scaffolding/supports, and once before work on the pavement commences. At one of the checks, the distance between measuring points shall be so small that all ridges and depressions clearly emerge. At the second check, measurements shall only be taken in representative sections, e.g. at mid-span, over the supports and at the construction joints. In the case of road bridges, 2 longitudinal profiles for each traffic lane shall be drawn symmetrically on either side of the lane's centre line, 2 m apart. The longitudinal profile shall be drawn to an illustrative scale, e.g. 1:2 vertically and 1:100 longitudinally. A theoretical line and data from measurements of deformations in the heaving / settlement of the formwork structure/foundations (see specification 84.1) shall be drawn in so that any deviations and the reasons for them are shown clearly. The profiles that are drawn shall be sent to the Project Owner.

In addition, surface evenness must be checked with a 1-m and a 3-m straightedge.

The results of the checks shall be used to assess the need for any corrective measures for the top surface layer, and for any adjustment of the profile of the road alignment.

Repair of fissures and cracks shall be checked with core samples on request.

84.521 Screeding and finishing of bridge deck that is to be covered with asphalt

- e) In the event of nonconformities exceeding the tolerances specified in specification 84 d), the contractor may be required to mill/grind the bridge deck until it is in line with the permitted deviations, or to pay for a corrective layer of bituminous material.

A concrete deck which is to have waterproofing shall also be as free as possible of irregularities. All such defects with a height over 3 mm must be removed, for example by grinding.

84.522 Screeding and treatment of concrete surface course

- a) Comprises surface of monolithically cast surface course and of concrete topping on both carriageways and walkways. Grinding of concrete surface courses to greater evenness than is stipulated in this specification is covered by specification 84.67.
- c) Unless otherwise indicated in *the special specifications*, it shall be agreed with the Project Owner if in connection with choice of screeding level a margin is to be added to enable grinding/milling of the cover after it has cured, so that any deviations can be corrected without the cover becoming too thin. Immediately, and in pace with screeding/repair of any surface deviations, the surface shall be roughened by grooving the carriageway/walkway at right angles to the direction of traffic. The groove depths shall normally be 1-2 mm. Protection against dehydration shall then be applied immediately.

The bridge deck shall be impervious all over and slope to drains as shown in the plans. Particular accuracy is required with respect to achieving an even, impervious surface at construction joints. The deck shall have no depressions where water can accumulate. All defects in the surface of the concrete that are associated with the production shall be repaired by a method accepted by the Project Owner.

- d) The upper edge of the completed surface course of concrete shall satisfy the following tolerances:

Table 84.5-1				
Evenness class	1	2	3	4
3-m straightedge measurement: Permitted deviation, Aperm.	±3 mm	±4 mm	±5 mm	±6 mm
Up to 3 irregularities larger than Aperm. are allowed per 30 m traffic lane, but not over (Amax):	±4 mm	±5 mm	±6 mm	±8 mm
1 m straightedge measurement: Permitted deviation, and permitted level deviation in the form of burrs, peaks, pits, bursts and joint edges:	±2 mm	±2 mm	±3 mm	±4 mm
Permitted deviations from correct transverse slope measured over 2 m:	±3 mm	±3 mm	±5 mm	±6 mm

Unless otherwise specified in *the special specifications*, the surface course shall satisfy the requirements for Evenness Class 3.

See specification 84 for measuring method and associated definition of nonconformities. The requirements in specification 84 regarding total building tolerance and max. deviation from correct height difference measured within 20 m also apply to the upper edge of a completed surface course of concrete. Burrs, burst and peaks shall be ground down to a slope of max 1:5.

84.523 Screeding and working of bridge deck as a base for concrete topping

- c) The bridge deck shall be levelled with vibrating compacting equipment and if necessary supplementary screeding shall be performed.

The screeding shall be such that the concrete is homogeneous and well compacted right up to the surface, and so precise that the requirements regarding cover and minimum thickness of the overlay are complied with. The surface shall be free of honeycombing, cement slurry or other defects. After screeding, the surface shall be grooved at right angles to the carriageway with the aid of a brush, "groover" etc.
- d) The surface shall satisfy Tolerance Class 3 in specification 84 d), unless otherwise specified in *the special specifications*.

84.53 Exposure of aggregate by high-pressure hosing

- a) Comprises high-pressure hosing of the surface of setting concrete to remove the upper cement slurry layer from the surface of the concrete. Also covers delivery and application of retarding agent, cleaning of structural components that are soiled by slurry water, collection and deposition of slurry water so that it does not cause contamination, and the problems that hosing with water might present for other work.
- c) Pressure hosing shall be carried out with clean water, with the addition of compressed air if necessary. Hosing shall be carried out before the concrete surface has set, but not so early or with such pressure that the concrete below the slurry layer is damaged.

84.54 Curing measures

- a) Covers materials and work for finishing treatment of cast concrete additional to the protective measures in specification 84.4.
- c) If the weather conditions are such that the concrete is exposed to dehydration, the curing measures shall be carried out immediately and in pace with screeding/repair of any surface deviations.

84.541 Curing with a curing compound

- a) Covers application of curing compound to a fresh concrete surface.

If the surface of the concrete is not exposed to dehydration, the specification may be dropped or the time of the application may be postponed according to agreement with the Project Owner.

- b) The curing compound must be documented to function without cracking or heaving, even if it is exposed to wind.
- c) The curing compound shall be applied evenly in a quantity and with equipment such that full cover is achieved (experience indicates using 0.4 – 0.5 l/m²) immediately after finishing treatment of the surface.

The curing compound must not be applied to construction joints and reinforcement. The curing compound must not be applied by spraying when it is windy.

84.542 Curing by covering with plastic sheeting or similar

- a) Comprises covering of fresh/curing concrete surface with plastic sheeting or other water-tight cover.
- b) The plastic sheeting must be robust enough to tolerate the traffic and loads that it might be subjected to. If the contractor chooses to use insulation mats of Ethafoam or similar for insulation against low temperatures, these may be regarded as having a similar moisture-insulating effect as plastic sheeting, provided that the mats are undamaged and have sealed lap lengths and edge zones.
- c) On a fresh concrete surface, the plastic sheeting shall be applied immediately after the concrete surface has been screeded/troweled.
If the specification is described for a formwork-covered surface, the cover shall be applied immediately after stripping. The cover shall be held in/remain in place for at least a week unless otherwise specified in *the special specifications*.

If there is no risk of frost, the surface of the concrete shall be kept moist. If necessary, it shall be watered under the sheeting.

84.543 Moist curing involving water sprinkling

- a) Comprises continuous sprinkling of water onto curing concrete

At below-zero temperatures or when there is risk of frost, the specification shall be omitted and replaced by other finishing treatment according to agreement with the Project Owner.

- c) Water sprinkling shall start as soon as the setting of the concrete has progressed so far that the surface of the concrete tolerates it and shall continue until the concrete is at least 4 days old unless otherwise specified in *the special specifications*.
Bridge decks shall be kept continuously moist for at least 7 days.

84.544 Moist curing with wet geotextile fabric

- a) Comprises all materials and work associated with moist curing of a concrete surface by laying out mats that store water and keep them moist.

At below-zero temperatures or when there is risk of frost, the specification is omitted and replaced by other finishing treatment according to agreement with the Project Owner.

- b) Geotextile fabric or other material that can function as a water reservoir shall be used.
- c) The fabric shall be laid out as soon as the concrete surface tolerates it and be kept constantly wet for at least one week.

84.545 Protection against exposure by postponing formwork stripping

- a) Comprises all work and costs associated with keeping the formwork as protection against exposure to chloride-containing air and sea spray beyond the normal stripping time.
- c) Unless otherwise stated in *the special specifications*, the formwork shall remain in place for at least 7 days after casting.

The formwork may be loosened from the surface of the concrete when adequate strength has been achieved (see specification 84.2), but shall then be pressed up against the concrete again and remain there until stripping.

84.546 Curing measures for bridge decks

- a) Comprises all materials and work involved in systematic curing measures for bridge decks or other structural components, i.e. curing compound, plastic sheeting or Ethafoam heat insulation and tarpaulin.

Several of the curing measures described in separate specifications above are included in the specification.

- b) Curing compound shall fulfil the requirements in specification 84.541. Plastic sheeting/Ethafoam mat must fulfil the requirements in specification 84.542 and have a width of approx. 2 metres. Tarpaulins shall be impervious and undamaged.

- c) Work with plastic sheeting and tarpaulin is assumed largely to be carried out from walkways on either side of the bridge deck (see specifications 84.131 and 84.141). Curing agent shall be applied immediately after screeding and if necessary repair of surface defects. The curing compound spray apparatus shall have sufficient capacity and range to apply continuous membrane to the entire deck.

As soon as 2 new metres of deck length have been levelled and curing compound applied, the surface shall be further sealed with plastic sheeting, which shall be laid with an overlap. In the cold season, and in conditions where there is a risk of thermal cracking (for example with thick concrete layers or large variation in concrete thickness), Ethafoam mats shall be used instead of plastic sheeting.

As soon as a deck length corresponding to the width of the tarpaulin has been covered with plastic sheeting/Ethafoam, the tarpaulin shall be laid over it. The tarpaulin shall be pulled tight over the deck and secured well so that it cannot blow off.

The whole cover must remain in place for a minimum of 7 days.

84.55 Heat insulation of concrete

- a) Comprises heat insulation to reduce temperature differences in concrete, and delivery, assembly, reading and reporting of a sufficient number of measurement points to document the result achieved. Heat insulation to prevent frost damage or bring about more rapid curing is covered by specification 84.4.
- b-e) Insulation can be carried out with covering/insulating materials and/or formwork, and shall be adjusted with respect to degree of insulation and duration such that specified control criteria are fulfilled. Unless otherwise specified, the temperature differences within the cast section shall not exceed 20°C. The number and positioning of measuring points shall be as specified in *the special specifications*. The contractor shall present calculations and documentation to show that the measures are sufficient in good time before the work takes place.
- x) Quantity shall be measured as the planned area to be heat insulated. Unit: m²

84.56 Heat insulation of metal surfaces against which concrete is cast

- a) Comprises heat insulation and any heating of planned metal surfaces against which the concrete is placed, for example steel beams, supports and protruding embedded parts. The specification shall normally be employed only during the cold season.
- Insulation of steel formwork and other metal in contact with concrete which the contractor chooses to use shall be calculated into other relevant specifications.
- c) The measures shall as a minimum ensure above zero temperatures in the metal and prevent frost damage to the concrete. When the metal forms part of the formwork for a cast section, the degree of insulation of the metal must be at least equivalent to the degree of insulation of the surrounding formwork. See *the special specifications* for more detailed requirements and/or information.
- x) Quantity shall be measured as area of insulated metal surface. Unit: m²

84.57 Cooling of concrete

- a) Comprises all costs associated with cooling of concrete and delivery, assembly, reading and reporting of a sufficient number of measurement points to document the result achieved.
- b-e) For requirements regarding maximum curing temperature, temperature differences across the section and between cast sections, if relevant maximum surface temperature during curing, and any other requirements, see *the special specifications*. Unless otherwise specified:
- maximum curing temperature shall not exceed 65°C
 - the temperature gradient across the section shall not exceed 20°C
 - the difference between the average temperatures in two adjacent sections shall not exceed 15°C if the retaining length between cast sections exceeds 5 metres.
 - the maximum surface temperature shall not exceed 40°C if the surface is exposed to chlorides.

For the scope of the measures, the control criteria for applying them, the combination of measures described in specifications 84.55 – 84.58, and the number and location of measuring points, see *the special specifications*.

- x) Quantity shall be measured as the planned volume of concrete. Unit: m³

84.571 Cooling of fresh concrete

- a) Comprises all costs for cooling fresh concrete, such as use of chilled mixing water, addition of ice to the mixture, washing of aggregate with cold water, cooling of fresh concrete with liquid nitrogen etc.
- b-e) See *the special specifications*.

84.572 Delivery, assembly and embedding of cooling pipes

- a) Comprises delivery, assembly and embedding of cooling pipes in massive concrete structures in accordance with *the special specifications*.

- b) Unless otherwise stated in *the special specifications*, steel pipes with diameter 25 mm and an untreated surface shall be used.
- c) The pipes shall be laid in coils as specified in *the special specifications*.
- x) Quantity shall be measured as length of cooling coils, including bends, joints, connections etc. Unit: m

84.573 Cooling with water, rigging and operation

- a) Comprises rigging of cold water supply, pumping equipment and outlet for cooling water and operation and maintenance of pumps and other equipment that is necessary to ensure effective circulation of cooling water in embedded cooling pipes in concrete structures. Also includes monitoring and follow-up of cooling according to the specified criteria.
- c) For pumping capacity and the criteria according to which the cooling must be controlled, see *the special specifications*.
- x) Costs are specified as a lump sum. Unit: LS

84.574 Grout injection of cooling pipes

- a) Comprises all materials and work involved in grouting of cooling coils embedded in concrete structures.
- b-c) See *the special specifications*. Unless otherwise specified, cement grout of the same quality as for prestressed ducts shall be used for grouting (see specification 84.374).
- x) Quantity shall be measured as length of cooling coils, including bends, joints, connections etc. Unit: m

84.58 Heating of adjoining structural components

- a) Comprises all costs for heating of structural components against which concrete is placed, to avoid large temperature differences between cast sections.
- b-c) Heating shall be carried out from the surface and/or by means of embedded heating cables or similar. The heating must be adapted in scope and duration so that the specified criteria are met. See *the special specifications*.
- x) The costs are specified as a lump sum. Unit: LS

84.6 Mechanical treatment of cured concrete

- a) Comprises specified mechanical treatment of cured concrete, cleaning of treated surface and any other surfaces that have been soiled during the work, and loading and removal of the waste materials from mechanical treatment.
- x) Quantity shall be measured as planned area. Unit: m²

84.61 Exposure of coarse aggregate at the concrete surface

- a) Comprises exposure of coarse aggregate at the surface of the concrete pursuant to *the special specifications*.

84.62 Cleaning of concrete surface, dry methods

- a) Comprises cleaning the surface of cured concrete by sand-blasting, blast cleaning or similar methods without addition of water until it is clean, mechanically strong, and in compliance with the requirements that the subsequent treatment/addition of layers makes with respect to the preliminary work. Curing compound, contaminants such as fat, oil etc., concrete mud (watery/porous cement paste) and mechanically weak cement slurry must be removed. Any smooth areas must be roughened. Finally, sand, dust and other loose particles must be completely removed.
- c) The air compressor must be equipped with water and oil separators.
Sand and loose particles must be removed with water- and oil-free compressed air or vacuuming, if desired supplemented by brushing of the surface.

All surfaces that the next layer is to come in contact with must be cleaned.

The cleaned surface shall be inspected by the contractor's inspection manager and the Project Owner's independent inspector before the next work operation can start.
- e) It must be checked that wax-based curing compound has been completely removed, for example by scraping with the tip of a knife.

The potential adhesiveness of the surface of bridge decks to which waterproofing and a surface course are to be applied shall be checked in connection with screeding tests. The adhesive strength requirement is a minimum of 1.5 N/mm² or concrete failure. The scope of the testing shall be at least 1 test consisting of 3 pull-offs per 50 m² for the first 300 m², then 1 per 200 m² if the first 6 tests are satisfactory.

84.63 Cleaning of concrete surface, wet methods

- a) Comprises cleaning of concrete surface with methods that add water, such as high pressure hosing, sand blasting, water jetting etc. The result of the cleaning shall satisfy the requirements in specification 84.62.

- c) Pressure, water quantity and temperature and if relevant sand quantity shall be adapted to the nature of the base and the requirements made. All loose particles shall be removed by hosing, if necessary supplemented by brushing of the surface before the surface dries.

The surface that has been water jetted and cleaned shall be inspected by the contractor's inspection manager and the Project Owner's independent inspector before the next work operation starts.

- e) As in specification 84.62.

84.64 Chiselling of concrete surface

- a) Comprises chiselling of the cured concrete surface in accordance with *the special specifications*.

84.66 Hammerdressing of concrete surface

- a) Comprises hammerdressing of the cured concrete surface in accordance with *the special specifications*.

84.67 Grinding of the concrete surface

- a) Comprises all costs associated with grinding of a cured concrete surface in order to correct irregularities and depressions etc. Is intended to be used to achieve greater evenness than that described in specification 84.522.
- c) The grinding shall be carried out with equipment that is adequately designed for this work, and which has the stability and flexibility to fulfil the evenness requirements that are made.
- d) Unless otherwise stated in *the special specifications*, the concrete surface after grinding shall satisfy the tolerances for specification 84.522, Evenness Class 1.

84.68 Milling of concrete surface

- a) Comprises milling the cured concrete surface in accordance with *the special specifications*.

84.7 Concrete elements ready for assembly

- a) Comprises production and delivery, transport, storage and prescribed assembly of prefabricated concrete elements, including struts to secure the elements in the correct position during the construction period, repair of any damage suffered by the elements, and responsibility for the costs due to damage to the elements.

Includes all materials and work for the production of the elements, such as formwork, ordinary reinforcement and prestressing tendons, concrete, embedded parts, steel detail, recesses etc. as specified in *the special specifications* or on drawings.

For the shape and size of the concrete elements, see *the special specifications*.

Parapets and bearings are covered by specifications 87.2 and 87.3, respectively.

The supplier of concrete elements shall be certified pursuant to current standards by an accredited supervisory body in the class to which the products belong.

- b-c) Concrete elements ready for assembly shall be manufactured and be in compliance with NS-EN 13369. All materials and all production shall be in compliance with the technical description of the individual relevant specifications, for example 84.2 Formwork, 84.3 Reinforcement, 84.4 Concreting and 84.5 Treatment of fresh and hardening concrete.
- d) For tolerance requirements regarding production and assembly, see the documents in which the elements are described (e.g. Handbook 100 Bruhåndboken (Bridge handbook – Norwegian text only), drawings and *the special specifications*).
- x) Quantity shall be measured as weight of planned elements, assuming a density of 2.5 tons/m³. Unit: ton

84.71 Delivery and assembly of beam and slab elements

- a) Comprises all costs up to the handover of beam and slab elements, assembled free of damage and with the necessary bracing of the structure.

84.711 MOT beams (Prefabricated modified inverted T-beams)

- b-e) See Handbook 100, Bridge Chapter 3 and *the special specifications*.

84.712 PLA elements (Prefabricated plate elements)

- b-e) See Handbook 100, Bridge Chapter 3, and *the special specifications*.

84.713 DT elements (Prefabricated double T-elements)

- b-e) See *the special specifications*.

84.714 Prefabricated footbridge elements

- b-e) See *the special specifications*.

84.72 Delivery and assembly of deck components

- a) Comprises delivery and assembly of deck components, including delivery and production of accessories described in the assembly instructions.

- 84.725 Prefabricated truss plates**
- a) Comprises delivery and assembly of prefabricated truss plates.
 - b-e) The truss plates shall be fabricated in accordance with the Directorate of Public Roads' Bridge Division's Report no. 3 "Formwork systems for beam bridges" (Norwegian text).
 - x) Quantity shall be measured as number or area of truss plates. Unit: m²
- 84.73 Edge elements**
- a) Comprises delivery and assembly of concrete elements as specified in *the special specifications*.
Concrete elements are covered by Specification 87.2.
 - c) The elements shall be assembled such that they follow the theoretical curvature shown on drawings. Sighting along the row of elements should reveal no pronounced discontinuities or bends.
 - d) The elements shall be assembled according to the tolerance requirements specified in Specification 84 for the accuracy class applying to the structure.
- 84.74 Culvert elements**
- a) Comprises all costs associated with delivery and assembly of culvert elements, including delivery and production of accessories described in the assembly instructions.
The work of excavation, preparing/compacting the ground and backfilling is covered by Specification 81.
 - b-e) See *the special specifications*.
- 84.75 Column elements**
- a) Comprises delivery and erection of columns in recesses in the foundation, filling these recesses with concrete and temporary bracing of the columns.
 - b-e) See *the special specifications*.
- 84.76 Delivery and assembly of foundation elements**
- a) Comprises delivery and assembly of foundation elements, including delivery and production of necessary accessories.
Excavation work, preparation/compaction of the ground and backfilling forms part of Specification 81.
 - b-e) See *the special specifications*.
- 84.77 Delivery and assembly of deck components for beam/girder bridges**
- a) Comprises delivery and assembly of concrete elements for the decks of girder bridges (steel girder bridges, plate girder bridges etc.) It includes the delivery and production of necessary accessory materials.
 - b-e) See *the special specifications*.
- 84.8 Gluing, surface treatment and accessories**
- a) Comprises materials and work associated with gluing, filling cracks, surface treatment and accessories and special work.
 - b-c) The products used shall be documented as suitable for the purpose, and the production shall be in accordance with the supplier's instructions.
- 84.81 Gluing with epoxy**
- a) Comprises all materials and work associated with gluing concrete with epoxy, including preliminary work and finishing work.

If cleaning of cured concrete by means of sand blasting or similar methods is required, a separate specification shall describe this (84.62).

Any temporary covers (tents) are covered by specification 84.18.
 - b-c) The epoxy glue shall be suitable for load transferring purposes. Used on vertical surfaces, the glue should be tixotropic.

Materials that are to be glued in position must be secured while the epoxy glue is still tacky and not be displaced before the epoxy glue is fully hardened.

If the epoxy glue hardens so much that it is no longer tacky, it should be scraped away if possible or the surface should be roughened before new glue is applied.

Surfaces to which epoxy are applied shall be dry and clean.
 - x) Quantity shall be measured as planned glued surface area. Unit: m²

84.811 Gluing of fresh concrete to cured concrete with epoxy

- a) Comprises delivery of epoxy materials, cleaning of cured concrete surface, application of glue, pressing the fresh concrete against the epoxy glue, and measures to ensure that the epoxy glue and concrete harden.
- c) The glue joint shall be as thin as possible, but thick enough for the epoxy to have full contact with the fresh concrete. The rate of application of the glue must be adapted to the progress of the concreting, so that the glue over the whole surface is tacky when the concrete is placed against it.
- x) Quantity shall be measured as planned glued surface area. Unit: m²

84.812 Gluing of cured concrete, metals etc. to cured concrete with epoxy

- a) Comprises delivery of epoxy materials, cleaning of surfaces that are to be glued together, application of glue and securing of the parts that have been glued together in the correct position without displacement until the epoxy glue has hardened sufficiently.
- c) The glue joint shall be as thin as possible, but thick enough to fill the entire space between the elements that are being glued together.
- x) Quantity shall be measured as planned glued surface area. Unit: m²

84.82 Gluing with cement slurry

- a) Comprises delivery of materials and the work associated with slurring the concrete surface before casting a concrete overlay.

If the surface to which glue is to be applied is required to be cleaned by mechanical methods, this is covered by specification 84.6.

- b-c) The slurry grout may be mixed using cement and well graded casting sand in the ratio 1:1 and water containing latex or a similar adhesion-improving additive. The mix ratio water:latex = 2:1. The type of latex shall be submitted to the Project Owner. The consistency of the slurry grout shall be adjusted to the absorption capacity of the base layer.

The slurry grout shall not be mixed more than 30 minutes before use, and shall be applied so late that it does not dry before the concrete is cast.

The slurry grout shall be worked well into the base layer by sweeping both in the length and the breadth direction with a piassava broom or similar method. Mechanical methods must be used on large surfaces. The base layer should be dry when the slurry is applied.

- x) Quantity shall be measured as planned slurried area. Unit: m²

84.83 Surface treatment of concrete

- a) Comprises all materials and work for surface treatment of concrete, including necessary preliminary and finishing work. If cleaning of the concrete surface by mechanical means is required before the surface treatment, this is covered by specification 84.6. The surfaces to be treated are detailed in *the special specifications*.

- b-c) For requirements regarding which aggressive agents the treatment is to provide protection against, and which properties are to be documented, see *the special specifications*. The work shall be in accordance with the instructions of the materials supplier.

- x) Quantity shall be measured as planned treated area. Unit: m²

84.831 Impregnation of concrete surface

- a) Comprises delivery and application of impregnation agent on cured concrete surfaces except on carriageways.

84.832 Surface coating on concrete

- a) Comprises delivery and application of surface coating on cured concrete surfaces except on carriage ways.

84.833 Anti-graffiti treatment

- a) Comprises all materials and work for anti-graffiti treatment of concrete surfaces.

84.84 Waterproofing products for construction joints

- a) Comprises all materials and work for specified accessories to be used to make construction joints water-tight.
- b) The products shall be installed and used in accordance with the supplier's instructions. The surface on which the products are installed shall be sufficiently plane, and the necessary number of clips or other installation accessories shall be used to ensure that the products are in contact with the construction joint along its full length.
- x) Quantity shall be measured as the planned length of waterproofing product. Unit: m

- 84.841 Injection hose**
- a) Comprises delivery and installation/embedding of injection hose with accessories and actual pressure injection of epoxy or polyurethane. In addition to mounting/embedding, it also includes creating a plane surface that the hose can be mounted on.
 - b) Any requirements regarding the hose and injection material/injection specification shall be specified in *the special specifications*.
 - c) Injection hoses are normally sectioned in lengths of up to about 5 m, which are injected with separate injection inlets.
- 84.842 Swelling sealing strips**
- a) Comprises delivery and assembly of sealing strips of bentonite clay which swell as they absorb water. Swelling strips are only used where the construction joint will be permanently under water, not where they may be wet and dry alternately.
 - b) Where the structure will be subjected to salt water, the sealing strip shall be of a type that functions under such conditions. Documentation of functioning in salt water shall be submitted.
- 84.843 Waterstop for concreting joints**
- a) Comprises delivery and installation including any welding of waterstops. Also comprises all supplements waterstops might entail with respect to adaptation of formwork etc.
 - b) For type of waterstop, dimensions and materials, see *the special specifications*.

Before being embedded, waterstops shall be cleaned of oil, grout residue etc. Waterstops shall be braced and secured, so that they do not move out of position during casting.

In particular it must be ensured that the concrete is fully compacted and fills all cavities around waterstops.
- 84.85 Joints in concrete**
- a) Comprises all materials and work associated with joints in concrete, including necessary adjustment of formwork and other works. Formwork for joint openings is covered by specification 84.254.

For joints that are exposed to traffic, i.e. bridge joints, see specification 87.4.
 - x) Quantity shall be measured as planned joint length. Unit: m
- 84.851 Waterstop for joints**
- a-x) As in specification 84.843. The waterstop profile shall have an easily deformable part in the middle that ensures a impervious joint in the event of joint movements.
- 84.852 Dowels**
- a) Comprises delivery and mounting of dowels, including adaptation of formwork etc.
 - b) Dowels shall be of plain steel, acid-resistant quality class A4. A lubricant shall be applied to the dowels, or alternatively a sheath half the length of the dowel. For dowel dimensions, see *the special specifications*.
 - c) Dowels shall be mounted in the direction of movement of the concrete component, and be braced/ supported so that they are not displaced during casting.
 - x) Quantity shall be measured as number of dowels. Unit: no. (of dowels).
- 84.853 Joint filler**
- a) Comprises delivery and installation of material that fills the joint space and prevents direct contact between structural components, for example bitumen-impregnated wooden fibreboard or cardboard etc.
 - b-c) See *the special specifications*.
 - x) Quantity shall be measured as area of joint filler. Unit: m²
- 84.854 Sealing with joint filler, joint ledges etc.**
- a) Comprises all materials and work for filling/sealing of joints with joint filler, joint ledges etc. in accordance with *the special specifications*.
 - b) For type of joint filler, see *the special specifications*.
 - x) Quantity shall be measured as length of joint. Unit: m
- 84.855 De-bonding agent in joints**
- a) Comprises delivery and application of agent to prevent bonding between concrete components in joints.
 - b-c) See *the special specifications*.
 - x) Quantity shall be measured as planned area. Unit: m²

84.86 Embedded parts, threaded casings, bolts etc.

- a) Comprises delivery, assembly and embedding of specific embedded parts, threaded casings, bolts etc., as indicated in the plans and in *the special specifications*, and which is not covered by other specifications such as 87.2 Parapets and 87.3 Bridge bearings. Grouting of dowels and reinforcement in holes drilled in existing concrete are covered by specification 88.3245.
- b) Materials shall satisfy the requirements specified in *the special specifications*.

For embedded parts of hot dip galvanized iron and steel, precautionary rules must be complied with to avoid chemical reaction and gas development through contact with cement paste/cement water with dechromatised cement.

Precautionary rules shall be documented as being effective and may be:

- insulation of zinc from cement paste with a sealing of epoxy coating strewn with fine, dust-free sand or
- chrome-containing zinc coating as a result of a separate finishing process after the galvanising.

Any nails for securing the embedded parts which remain in the cover layer must be of stainless steel.

- c) The embedded units must be installed firmly in the mould and must be secured against displacement during the concreting.
A template may be used for exact placing and securing of the embedded parts.
- d) Unless otherwise specified, the tolerances in NS 3465 Appendix F Figure F.1d and e, Tolerance Class 1 apply.
- x) Quantity shall be measured as number of embedded units. Unit: no. (of pieces).

84.861 Embedded parts

- a) Comprises specified embedded parts.

84.862 Embedded threaded casings

84.863 Embedded bolts

84.87 Embedding in recesses, grouting etc.

- a) Comprises delivery of materials and embedding/grouting in the structure of parts that are not covered by other specifications, such as 87.2 Parapets, 87.3 Bridge bearings and 87.4 Joint structures.

84.871 Embedding/grouting of bolts in recesses

- a) Comprises delivery of bolts and grout and embedding of bolts in recesses, as specified in *the special specifications*.
- b) For the quality and dimensions of bolts, see *the special specifications*. Unless otherwise indicated, the embedding grout must satisfy strength class B45.
- c) Recesses must be cleaned and free of contaminants or remnants of wood materials, expanded polystyrene etc. Where the recess is braced with spiro ducts or similar, the duct itself must be removed.

The bolts shall be installed with precision and shall be secured against displacement until the grout has cured sufficiently. The grout shall be compacted well and protected from harmful effects due to weather conditions etc.
- d) Unless otherwise specified, the tolerances in NS 3465 Appendix F Figure F1.d and e, Tolerance Class 1 apply.
- x) Quantity shall be measured as number of embedded bolts. Unit: no. (of bolts)

84.872 Grouting under steel plates etc.

- a) Comprises all materials and work for grouting of steel plates and other structural components. Embedding of bolts, claws etc. on steel plates, cleaning of surfaces against which casting is to take place, formwork, protective and curing measures etc. are included.
- b) Unless otherwise specified in *the special specifications*, ready mixed mortar with a minimum strength class of B45 shall be used, which contains expanding admixtures so that the grout has weak expansion in its plastic phase.
The maximum grain size of the mortar shall be chosen on the basis of the thickness of the grouting, according to the supplier's instructions. Any content of steel or plastic fibre shall be as specified in *the special specifications*.
- c) Specifications from the grout supplier regarding water quantity, mixing, time of use and application shall be followed. Unless another method is accepted by the Project Owner, the grouting shall take place by the grout flowing from one side to the other side of the component to be grouted. The formwork may be constructed on the side from which grout is being applied such that sufficient excess pressure is achieved to the grout all the way across. Alternatively, the grout can be pumped in through a hose which releases the grout roughly in the middle of and under the steel plate.
- x) Quantity shall be measured as area of steel plates/structural components under which grouting takes place. Unit: m²

STEEL

- a) Comprises all materials and work in connection with supply, transport, temporary storage, assembly and quality control of structures and structural components of steel.

Expansion joint structures, parapets, and support and equipment for draining are included in Specification 87.

- b) All materials shall be in accordance with current Norwegian standards for steel and the standards referred to in these provided that no different rules are specified in the following general specifications or in *the special specifications*.
- c) All execution shall be in accordance with current Norwegian standards for steel structures and the Norwegian standards referred to in these provided that no different rules are specified in the following general specifications or in *the special specifications*.

Execution shall be in accordance with the acceptance criteria for the various inspection classes specified in the individual general specifications or in *the special specifications*.

Work with the delivery shall take place in close contact and cooperation with the Project Owner. The Contractor undertakes to keep the Project Owner informed of work progress and shall inform him of any problems during the work that may be of significance for the product quality or delivery time.

- d) As specified in *the special specifications* or in the individual general specifications.
- e) Inspection is divided into three classes depending on the type of structure/work specification:

Inspection Class 1: Limited inspection
 Inspection Class 2: Medium inspection
 Inspection Class 3: Extensive inspection

The inspection class shall be selected in accordance with Table 85-1 unless otherwise indicated in *the special specifications*.

Table 85-1			
Structures/work specifications ¹⁾	Inspection classes		
	1	2 ²⁾	3
Welded connections			
Plate girders, full penetration butt weld			•
Plate girders, fillet weld/partial penetration butt weld		•	
Plate girders, other		•	
Rolled steel girder, full penetration butt weld			•
Rolled steel girder, fillet weld/partial penetration butt weld		•	
Rolled steel girder, other		•	
Cross bracing/wind bracing		•	
Steel deck, transverse full penetration butt weld in the bridge deck plate w/stiffeners			•
Steel deck, T connection with the diaphragm			•
Steel box, diaphragm other, side and bottom panels		•	
Steel box, other		•	
Truss, full penetration butt weld of chords in main and cross girders			•
Truss, transverse truss/wind bracing		•	
Truss, other		•	

Cable clamps and lower cable connection, suspension bridge			•
Cable stay connection, cable-stayed bridge			•
Truss of hollow sections, chords, full penetration butt weld			•
Truss of hollow sections, joints			•
Truss of hollow sections, other		•	
Bolt studs		•	
Parapets and other non-load-bearing elements ³⁾	•		
Bolted connections			
Slip-resistant (friction) connections in primary elements ⁴⁾			•
Slip-resistant (friction) connections in secondary structure ⁵⁾		•	
All other bolted connections ⁶⁾	•		
Corrosion protection			
Areas that are difficult to access			•
Other areas		•	

¹⁾ Structures or work specifications that are not covered by the table shall be indicated in *the special specifications*.

²⁾ If fatigue is governing, Inspection Class 2 shall be replaced by Inspection Class 3. This is to be specified in *the special specifications*.

³⁾ Welded connections on load-bearing structures shall have the same inspection class as the structural element.

⁴⁾ The main girder in I-girder bridges, members in load-bearing trusses etc.

⁵⁾ E.g. cross bracing and other secondary bracing.

⁶⁾ E.g. parapets, ladders, walkways etc.

The contractor shall carry out inspections in accordance with the requirements for the individual general specifications and to an extent depending on the inspection class.

The Project Owner has the right to inspect all aspects of production, including on subcontractors premises.

The Project Owner shall as far as possible arrange his inspection work so that the fabrication work is disturbed as little as possible. However, inspections are expected to be carried out during normal working hours and the contractor's loss of time or inconvenience due to the inspection is not the concern of the Project Owner. The Project Owner shall be notified at least three working days in advance when an inspection that the Project Owner is to carry out or witness has to be carried out. The contractor undertakes to freely provide the necessary labour and cranes for lifting and turning etc. and to provide the Project Owner with assistance in taking measurements. He also undertakes to provide a safe work platform for the inspector where necessary.

On the Project Owner's request, all steel components shall be submitted for inspection as they are manufactured, and in such a way that all phases of the work can be inspected.

- x) Quantity shall be measured as net planned weight according to final bills of materials. The density for steel is considered to be equal to 7.85 kg/dm³. Unit: ton

85.1 Delivery of steel materials

- a) Comprises delivery and inspection of steel materials. All costs prior to works carried out in the fabrication workshop are included in the specification. If the materials are to be delivered with authorized inspection, the costs of this procedure are also included.
- b) Materials shall be delivered in accordance with the general technical delivery requirements in NS-EN 10021.

Unless otherwise specified in *the special specifications*, materials of types Structural Steel I and Structural Steel II (cf. Specification 85.11) shall be delivered with type 3.2 inspection certificates in accordance with NS-EN 10204 and other materials with type 3.1 inspection certificates in accordance with NS-EN 10204.

- c) The contractor shall ensure/check to see that the materials are delivered in accordance with the specifications and *the special specifications*.

All material certificates/proof demanded shall be reviewed and approved by the contractor before the materials are used in production. The certificates shall be available for the Project Owner and shall form a part of the final documentation.

The materials shall be clearly marked by the manufacturer and be handled and stored in such a way that they are not damaged and that their data (steel type, charge number, etc.) can easily be checked. The steel type shall be stated on the labelling. The contractor is responsible for the labelling and for ensuring that the labelling is maintained. The use of the materials shall be traceable.

- e) Inspection certificate 3.2 is based on the assumption that the materials are ordered from a manufacturer.

Materials delivered with inspection certificate 3.1 will not be inspected by the purchaser on the manufacturer's premises. They must therefore be checked by the contractor with respect to specific tolerances and surface condition as soon as they are received.

Special testing of materials can be required for materials without documentation of specific testing in accordance with NS-EN 10204 from the manufacturer, e.g. materials delivered from stocks. The contractor shall obtain the Project Owner's consent to use materials without documentation. These materials shall be inspected and checked by the contractor with respect to tolerances and surface condition. A sample shall be taken from each individual rod, plate, cast piece etc., if a stamped charge number cannot be found. If a charge number can be found on each individual rod, plate, cast piece, etc. the testing can be omitted if satisfactory documentation is submitted for the charge concerned. If several rods, plates, cast pieces etc. have the same charge number, and documentation is missing, the number of tests is decided by the Project Owner.

Testing shall take place in accordance with the requirements for testing in NS-EN 10025-1, Chapters 9 and 10 and Annex A.

The tests shall as a minimum comprise chemical composition, tensile test, impact resistance test and ultrasound inspection. If it is necessary to determine the delivery condition of the material, samples shall also be taken and a metallographic assessment made of the microstructure. The results of the test shall satisfy all requirements made of the material for the use in question. See also *the special specifications*.

- x) Quantity shall be measured as net planned weight according to final bills of materials. A density of 7.85 kg/dm³ is used in calculations.

No supplement shall be made for welds, and no deduction for bolt holes and weld joint preparation. Unit: ton

85.11 Delivery of rolled steel and filler metal for welding

- a) Comprises delivery and possibly testing of rolled steel and filler metal for welding.

b-e) **Rolled steel**

Steel types:

The Engineer shall decide on steel types in accordance with the rules below. The steel type shall be specified according to the designations in NS-EN 10027-1 and shall be specified in *the special specifications*.

Materials shall be grouped into Structural Steel and Non-Structural Steel.

Structural Steel is all steel that goes into the load-bearing structure or is welded to it. Structural Steel also comprises other structures of major importance for safety such as road safety barriers, stairs etc. Structural Steel is subdivided on the basis of stress conditions and loading type into Structural Steel I and Structural Steel II as shown in Table 85.11-1.

Non-Structural Steel comprises steel for use in parts of no structural importance.

Table 85.11-1	
Structural Steel I	Steel for use in connections that entail the steel being tension-loaded in the thickness direction or in connection with high restraint/triaxial stress (danger of delamination)
Structural Steel II	Steel for use in connections with uncomplicated stress conditions.
Non-Structural Steel	Steel for use in connections of no structural importance

Structural Steel:

For rolled plates and sections of Structural Steel, normalised or normalising rolled, weldable fine-grain steel in accordance with NS-EN 10025-3 (N/NL quality) or thermomechanically rolled, weldable fine-grain steel in accordance with NS-EN 10025-4 (M/ML quality) shall be used unless otherwise indicated in *the special specifications*.

Unalloyed Structural Steel in accordance with NS-EN 10025-2 may be used for secondary structures.

For hollow sections of Structural Steel, hot finished steel in accordance with NS-EN 10210-1 of the types indicated in Table 85.11-6 shall be used. For hollow sections that are to be welded, fine grained steel (NH grade) shall be used. At air temperatures lower than -30 degrees C, NHL grade steel shall be used.

Minimum nominal strength S355 shall be used for Structural Steel that is to be welded. Steel with a lower strength can be used for steel that is not to be welded and for steel that is not part of load-bearing structures (stairs, etc.). A lower steel strength can also be used for sections and steel rod. The maximum permitted nominal strength is S460. Any use of higher strength steels shall be submitted to the Project Owner.

To avoid brittle fractures, the Engineer shall determine maximum thicknesses for the various types of steel. National Appendix to NS-EN 1993-1-10 can be used for this purpose. Structural Steel for bridges shall be placed in Consequence Class 3 (CC3). CC2 can be used for Structural Steel of no significance to bridge safety or load-bearing capacity.

Table 85.11-2 lists permitted steel types with appurtenant maximum thicknesses for use in bridges, depending on minimum air temperatures in accordance with NS-3491-5. The table applies to CC3. The table is also based on the assumptions that the temperature fall due to radiation is included (Delta Tr = 0) and that the safety margin Delta TR = 0. This results in a minimum air temperature Tmd equal to the reference temperature TED. The table also includes a requirement that the testing temperature be a maximum of 20 degrees C higher than the reference temperature.

The thickness restrictions apply to steel that is susceptible to brittle fracture, i.e. fatigue loaded structures, tension loaded structures and welded structures. These values can also be conservatively used for Consequence Classes CC2 and CC1.

Table 85.11-2 Permitted steel types and appurtenant maximum permitted thicknesses for plates and steel sections								
Steel type	Sub-type	Charpy requirements in accordance with the product standards		Minimum air temperature in accordance with NS 3491-5 (°C)				
		Test temperature (°C)	Energy requirements Jmin (J)	-10 to -20	-20 to -30	-30 to -40	-40 to -50	< -50
S235 ¹⁾	JR	20	27	- ²⁾	-	-	-	-
	J0	0	27	40	-	-	-	-
	J2	-20	27	60	50	40	-	-
S275 ¹⁾	JR	20	27	-	-	-	-	-
	J0	0	27	35	-	-	-	-
	J2	-20	27	55	45	35	-	-
	N, M	-20	40	65	55	45	-	-
	NL, ML	-50	27	95	75	65	55	45
S355	JR ³⁾	20	27	-	-	-	-	-
	J0 ³⁾	0	27	25	-	-	-	-
	J2 ³⁾	-20	27	40	35	25	-	-
	K2, N, M	-20	40	50	40	35	-	-
	NL, ML	-50	27	75	60	50	40	30
S420	N, M	-20	40	45	35	30	-	-
	NL, ML	-50	27	65	55	45	35	25
S460	Q	-20	30	30	25	20	-	-
	M, N	-20	40	40	30	25	-	-
	QL	-40	30	50	40	30	20	10
	NL, ML	-50	27	60	50	40	30	20
	QL1	-60	30	70	60	50	40	30

¹⁾ S235 and S275 shall not be used for Structural Steel that is to be welded.
²⁾ - means that the steel type is not permitted for these temperature ranges.
³⁾ Unalloyed structural steel shall not normally be used in Structural Steel

Non-structural Steel

Unalloyed Structural steel in accordance with NS-EN 10025-2 can be used for rolled plates and sections of Non-structural Steel.

General delivery requirements for steel

The following tables show mandatory supplementary requirements that apply to the various steel types, depending on whether they are Structural Steel I, Structural Steel II or Non-structural Steel.

The tables indicate minimum requirements. For materials that are to be welded, the contractor must ensure that requirements are made with respect to chemical composition, carbon equivalent, hardness, notch impact strength etc. so that the finished welded structure meets the requirements cf. 85.24. Before delivery takes place, the contractor shall make sure that the material can be welded without problems using normal welding processes, e.g. by demanding weldability documentation from the steel manufacturer. The contractor must himself specify necessary supplementary options when placing an order.

When ordering rolled steel from the mill, the desired length tolerances must be stated. Rolled materials shall satisfy current tolerance requirements in accordance with Norwegian Standards for delivery of steel materials. Materials that have been strongly deformed shall be discarded, while materials that are evenly deformed by up to 3% may be straightened and used. The procedure used for straightening shall be submitted to the Project Owner before the work is carried out. See also *the special specifications*.

All steel materials shall be delivered after having been cleaned with by means of shot peening and primed with a light, zinc-rich primer unless otherwise stated in *the special specifications*. In open boxes, the weld shall also be given a coat of primer after weld inspection.

Structural Steel:

Newly rolled materials ordered directly from the mill (manufacturer) shall be used as far as possible for Structural Steel, and type 3.2 inspection certificates in accordance with NS-EN 10204 shall be required as documentation.

General technical delivery conditions for rolled plates and sections of Structural Steel shall be in accordance with NS-EN 10025-1 and for hollow sections in accordance with NS-EN 10210-1. For Structural Steel I, requirements for improved characteristics in Table 85.11-3 apply. The Engineer shall determine requirements for ZED in accordance with NS-EN 1993-1-10. This shall be stated in *the special specifications*, e.g. by adding '-Z' to the steel type designation (S355N-Z).

Table 85.11-3 Structural Steel I		
Product standard NS-EN 10025-3 and NS-EN 10025-4		
Steel type	Sub-type	Mandatory selections NS-EN 10025-3 and NS-EN 10025-4, Chapter 13
S355	N,M,NL,ML	Option 4: Applies to materials where improved deformation properties are required perpendicular to the surface. The material shall meet requirements in accordance with NS-EN 10164-Z25. ¹⁾
S420	N,M,NL,ML	
S460	N,M,NL,ML	Option 6: For flat products with a thickness ≥ 6 mm, the internal properties revealed through ultrasound testing in accordance with NS-EN 100164 shall meet the requirements for Class S1 according to NS-EN 10160.
S460	Q, QL, QL1	
		Option 7: In the case of wide flange beams with parallel flanges and INP beams, the absence of internal defects shall be verified by ultrasound testing in accordance with NS-EN 10164 to meet the requirements for Class 2.3 according to NS-EN 10306.
		Option 14: The notch impact characteristics and strength of flat products from each individual mother plate or coil shall be verified.
¹⁾ Z25 is valid up to a Z_{ED} value of 30 in accordance with NS-EN 1993-1-10. In the case of higher Z_{ED} values, Z35 shall be specified. The Engineer shall evaluate this.		

For Structural Steel II in accordance with product standard NS-EN 10025-3 and NS-EN 10025-4 (fine grain), the following mandatory selections apply:

Table 85.11-4: Structural Steel II		
Product standard NS-EN 10025-3 and NS-EN 10025-4		
Steel type	Sub-type	Mandatory selections NS-EN 10025-3 and NS-EN 10025-4, Chapter 13
S355	N, M, NL, ML	Option 14: The notch impact characteristics and strength of flat products from each individual mother plate or coil shall be verified.
S420	N, M, NL, ML	
S460	N, M, NL, ML	Applies to steel that is to be hot-dip galvanized: Option 5: The product shall be suitable for hot-dip galvanizing.
S460	Q, QL, QL1	Applies to steel that is to be cold formed: Option 12: Plates and strips with a nominal thickness ≤ 8 mm shall be suitable for production of cold rolled sections with bending radii as specified in 7.4.2.2.2-3

For Structural Steel II in accordance with product standard NS-EN 10025-2 (unalloyed Structural Steel), the following supplementary requirements apply:

Table 85.11-5: Structural Steel II	
Product standard NS-EN 10025-2	
Steel type	Mandatory selections NS-EN 10025-2, Chapter 13
S235J2+N	Option 19A: Delivery condition shall be +N
S275J2+N	
S355J2+N	
S355K2+N	
All steel types	Option 26: Maximum carbon content for sections shall be 0.18% Special requirement: Sections shall have a total aluminium content of minimum 0.06% Applies to steel that is to be hot-dip galvanized: Option 5: The product shall be suitable for hot-dip galvanizing Applies to steel that is to be cold-formed: Option 12: Plates and strips with a nominal thickness ≤ 8 mm shall be suitable for production of cold rolled sections with bending radii as specified in 7.4.2.2.2-3

For hot finished hollow sections, the following steel types shall be used with the mandatory choices indicated:

Table 85.11-6: Hot finished hollow sections, Structural Steel II		
Product standard NS-EN 10210-1		
Steel type	Sub-type	Mandatory selections NS-EN 10210-1, Chapter 5.2
S275 ¹⁾	J2H	Applies to steel that is to be hot-dip galvanized: Option 1.4: The product shall be suitable for hot-dip galvanizing
S355 ¹⁾	J2H	
S275 ²⁾	NH, NLH	Option 1.5: Weld repairs to the parent metal for unalloyed hollow sections are not permitted.
S355 ²⁾	NH, NLH	

¹⁾ Unalloyed structural steel shall not be used for structural steel that is to be welded
²⁾ Steel type S275NLH/S355NLH shall be used when the minimum air temperature is lower than -30°C

Non-Structural Steel

Newly rolled materials ordered directly from the mill (manufacturer) shall be used as far as possible for Non-Structural Steel, and type 3.1 inspection certificates in accordance with NS-EN 10204 shall be required as documentation.

General technical delivery terms for Non-Structural Steel shall be in accordance with NS-EN 10025-1 and for hollow sections in accordance with NS-EN 10210-1 or NS-EN 10219-1.

The following applies to cold-formed hollow sections:

Table 85.11-7: Cold-formed hollow sections, Non-Structural Steel		
Product standard NS-EN 10219-1, Annex A		
Steel type	Product form	Mandatory selections NS-EN 10219-1 5.2
S235JRH	CFRHS	Applies to steel that is to be hot-dip galvanized: Option 1.7: The product shall be suitable for hot-dip galvanizing
S275J0H		Option 1.8: Weld repairs to the parent metal for hollow sections are not permitted.
S355J0H	CFRHS	Option 1.9: Specific inspection and testing is required for unalloyed steel types JR and JO

Surface condition

Plates and universals in accordance with NS-EN 10163-1 and NS-EN 10163-2

- Structural Steel: Class B and subclass 3
- Non-Structural Steel: Class A and subclass 2

Sections in accordance with NS-EN 10163-1 and NS-EN 10163-2

- Structural Steel: class D and subclass 3
- Non-Structural Steel: class C and subclass 2

Steel rod in accordance with NS-EN 10221

- Structural Steel: class D or C. 1)
- Non-Structural Steel: class B

The class shall be specified in *the special specifications*. Steel rod used as Structural Steel is assumed to be tension- and fatigue-loaded. Class D will give the greatest depth for a radial defect of 0.25 mm. The largest diameter this requirement applies to is 80 mm. For diameters up to 120 mm, class C can be used, but here the greatest depth for a radial defect will be 1.0 mm. The class must be specified on the basis of the expected fatigue life.

Filler metal for welding

The parent metal and filler metal shall have a chemical composition and strength characteristics that are compatible. The filler metal shall be approved for use with the parent metal in question by a publicly recognised inspection institution. All filler metal shall be delivered with a 3.1 inspection certificate in accordance with NS-EN 10204 with indication of C, Mn, Si, P, S, Cr, Cu, V, Al, N and all other alloying elements. Flux for welding method 121 (SAW) can be delivered with test report in accordance with section 3.2 in NS-EN 10204.

Unless otherwise stated in *the special specifications*, filler metal that satisfies the following requirements shall be used in all load-bearing welded connections:

- Maximum hydrogen content in the weld deposit shall be 10 ml H₂/100 g. (When steel with CEV higher than 0.43 and/or mean yield strength higher than 520 MPa is used, and in the case of welds with especially high restraint, this requirement shall be stepped up to 5 ml H₂/100 g)

- The weld deposit's yield point shall be 100 to 150 MPa higher than the parent metal's minimum specified yield strength for welding of Structural Steel I. For welding of Structural Steel II and Non-Structural Steel, the weld deposit's yield point shall be a minimum of 10% higher than the minimum specified yield point.

With shielded arc welding, these requirements are usually met by using class 3YH basic electrodes in accordance with Det Norske Veritas's (DNV) rules. In the case of submerged arc welding and inert gas welding, they are also usually satisfied by using class IIY electrodes.

Powder, filler metal and ceramic backing shall be stored in accordance with the supplier's instructions.

- x) As in Specification 85.1 Unit: ton

85.12 Delivery of cast steel and cast iron

- a-e) Comprises manufacture of casting mould on the basis of a model, delivery of casting steel and casting iron, casting, cleaning, removal of ascension pipe and preparation for tooling, machining and surface treatment.

For cable sockets of cast steel, see Handbook 122 'Cables for suspension bridges and cable-stayed bridges'. See also *the special specifications*.

Further tooling and machining is included in Specification 85.222.

- x) As in Specification 85.1 Unit: ton

85.13 Delivery of bolts including nuts and washers

- a) Comprises delivery of bolts including nuts and washers. Surface treatment is included in the specification.

- b-e) Bolts and nuts shall be delivered with a type 2.2 test report in accordance with NS-EN 10204. Bolts and nuts shall satisfy the requirements of NS-EN ISO 898-1 and NS-ISO 898-2. Bolts of quality 8.8 shall be used for bolts without pre-loading (for bearing-type (shear) connections), and 8.8 or 10.9 for pre-loaded bolts (bearing type and slip-resistant (friction) connections). Non-pre-loaded bolts shall not be used in load-bearing structures.

Bolts and nuts in connections without pre-loading shall satisfy the requirements of NS-EN 15048-1 and -2.

Bolts, nuts and washers in connections with pre-loading shall satisfy the requirements of NS-EN 14399-1.

Bolts, washers and nuts shall be hot-dip galvanized in accordance with NS-EN ISO 10684. Bolts with a diameter of less than 12 mm shall be delivered acid-resistant.

Bolts shall be selected according to Table 85.13-1.

Table 85.13-1			
Without pre-loading			
Class	Bolts	Nuts	Washers
8.8	NS-ISO 4014	NS-ISO 4032	NS-ISO 7090
	NS-ISO 4017		

Table 85.13-2				
With pre-loading				
Class	Type	Bolts	Nuts	Washers
8.8 and 10.9	Type HR	NS-EN 14399-3 ¹⁾		NS-EN 14399-5 ¹⁾
10.9	Type HV	NS-EN 14399-4 ²⁾		NS-EN 14399-6 ³⁾

¹⁾ NS-EN 14399-3 and -5 replace BS 4395-1 and -2

²⁾ NS-EN 14399-4 replaces DIN 6914 and DIN 6915

³⁾ NS-EN 14399-6 replaces DIN 6916

To achieve the most even tightening force possible, a suitable lubricant shall be applied to pre-loaded bolts. See also Specification 85.25

x) Unit: kg

85.14 Delivery of bolt studs

a) Comprises delivery of bolt studs for composite connections steel/concrete.

b-e) When using the "lift ignition method", bolts of type SD 1) and type UF ceramic ferrules shall be used according to NS-EN ISO 13918, Table 4.

When inert gas or short-cycle welding is used, type SD bolts shall be used according to NS-EN ISO 13918, Table 4. In addition, Type UF ceramic ferrules shall be used to optimize the geometry of the weld deposit and to limit the reach of the weld arc on the workpiece. These welding methods shall only be used for welding position PA as defined in NS-EN ISO 6947.

The material shall be S235J2G3 + C450 according to EN 10025 2).

1) The designation SD indicates the dimensions and weight of shear dowels and specifies which ceramic ferrule, UF, is to be used during welding.

2) NS-EN ISO 13918 refers to previous versions of NS-EN 10025. A possible alternative would be to specify S355NL in accordance with NS-EN 10025-3.

Welding of bolt studs shall be done in accordance with NS-EN ISO 14555. Quality requirements regarding execution are given in NS-EN 13918: Table A.1.

Production tests shall be carried out in accordance with NS-EN-ISO 13918 for every 200 welded studs or part thereof.

x) As in Specification 85.1. Unit: kg

85.2 Tooling, machining and assembly of steel parts

a) Comprises all work in fabrication workshops (with the exception of surface treatment), which is necessary to deliver the steel structures in accordance with the requirements and *the special specifications*. Included in the specification are preparation of production drawings, bills of materials, welding schedules and welding procedure specifications, welding procedure tests, templates, jigs, preparations, tooling and machining (cutting, clipping, sawing, bending drilling, grinding, turning etc.), assembly and welding, partial trial assembly, internal transport, packaging, labelling, storage and all inspection of the parts. Also covers all costs relating to approval of welders and any extended inspection and post-inspection of discarded/repared welds cf. point c) below.

Surface treatment is included in Specification 85.3. Transport and assembly are included in Specification 85.4.

c) Steel structures built according to these guidelines shall only be delivered and assembled by fabrication workshops that have the necessary professional expertise and technical equipment. If the fabrication workshop (the contractor) does not have such expertise, qualified assistance shall be engaged.

By professional expertise is meant that the fabrication workshop has expertise in design, planning, execution of the work and inspection.

Steel construction workers shall have passed qualifying examinations. Unqualified steel construction workers who carry out work on steel structures shall be under the direct supervision of qualified personnel. For welders, see Specification 85.24.

- d) Tolerance requirements for the various structures and structural elements are specified below or in *the special specifications*. Unless otherwise stated in *the special specifications*, the tolerance requirements are given for unloaded structures at reference temperature +5°C.

For tolerance requirements for structural elements that are not covered in the following or in *the special specifications*, NS-EN ISO 13920, tolerance class A (Tables 1 and 2) and E (Table 3) apply.

Definition of deviation

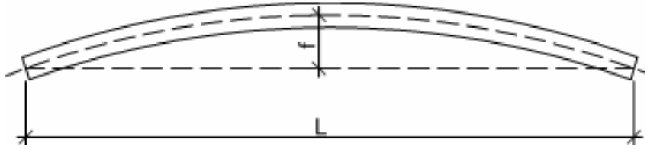

f = sag
L = measured length

Fig. 85.2-1 Assembled girder or column

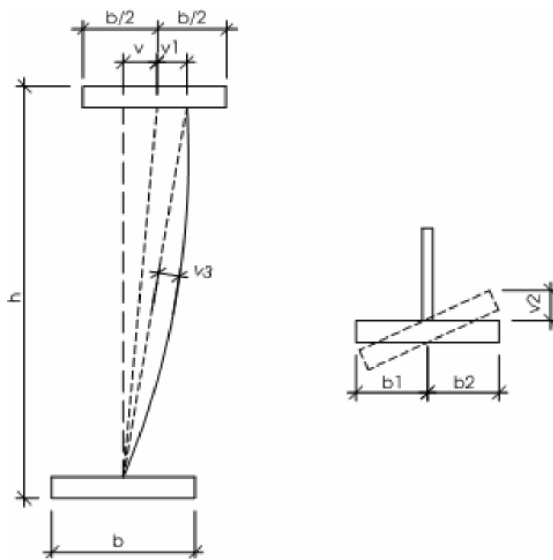

v = skew (vertical deviation) of web
v1 = eccentricity of web
v2 = skew (directional deviation) of flange
v3 = curvature (straightness deviation) of web
h = girder height

Fig. 85.2-2 Girder cross-section

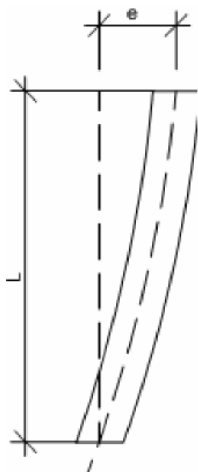

e = angle of deviation from the vertical for the column

Fig. 85.2-3 Column

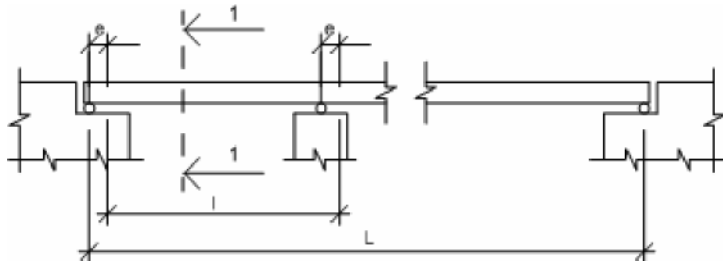

Elevation bridge

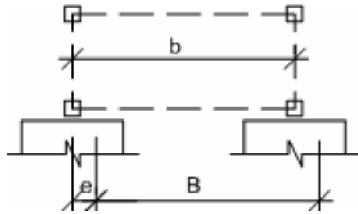

Section 1-1
e = eccentricity

Fig. 85.2-4 Erected girder

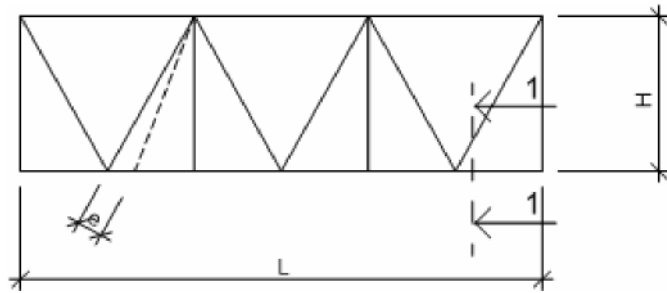

e = eccentricity of individual member
c = out-of-plane eccentricity

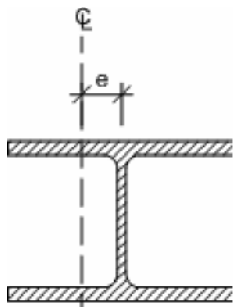

Section 1-1

Fig. 85.2-5 Structural element truss

Søyle = column

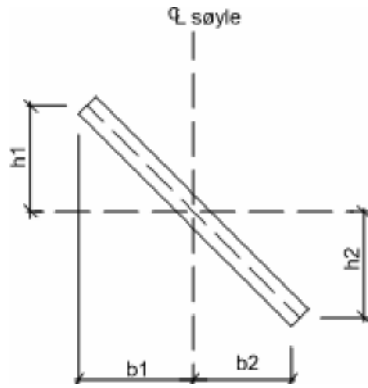

$h = h1 + h2 =$ directional deviation for end plates
 $b1 + b2 =$ measured length

Fig. 85.2-6 End plate

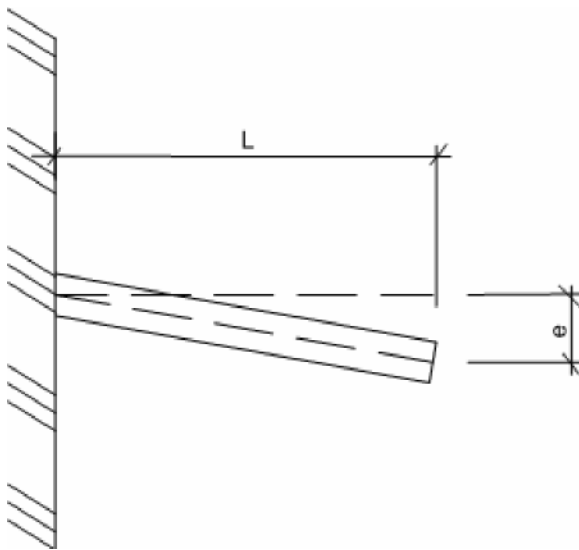

$e =$ directional deviation gusset plate

Fig. 85.2-7 Gusset plate



$f =$ camber

Fig. 85.2-8 Partial trial assembly at the fabrication workshop

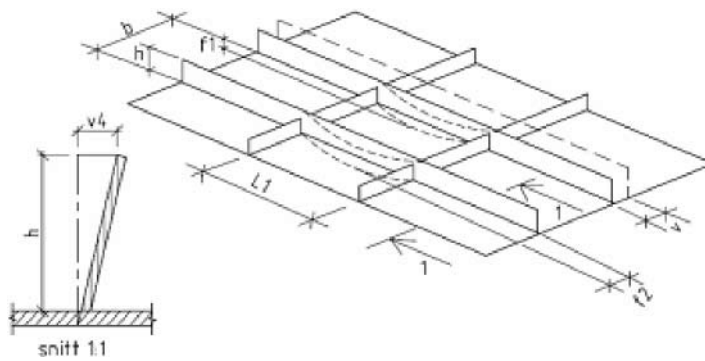

Fig. 85.2-9 Longitudinal and transverse stiffeners

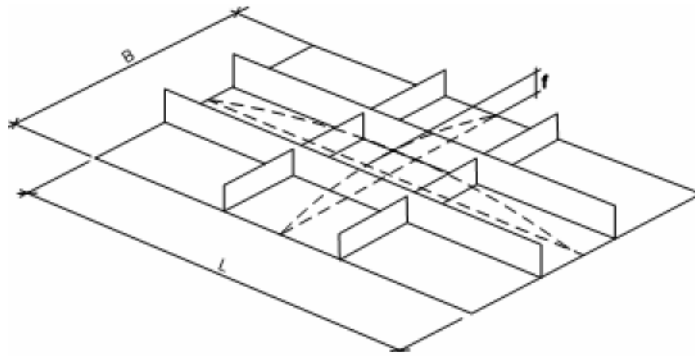
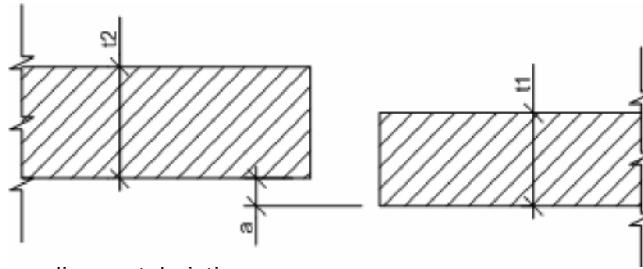
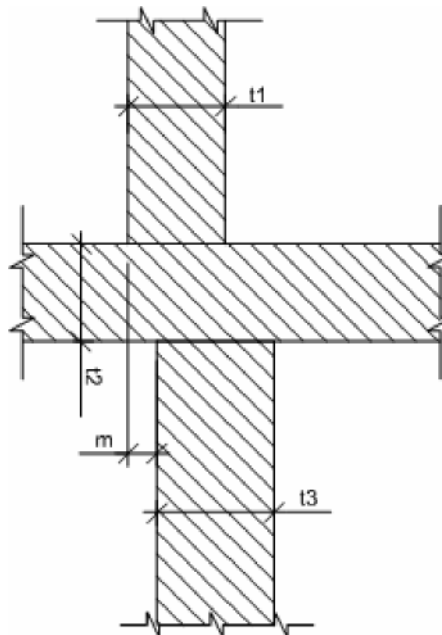

Fig. 85.2-10 Plate panels



a = alignment deviation

Fig. 85.2-11 Full penetration butt weld



m = alignment deviation

Fig. 85.2-12 Welded transverse joint

Tolerance requirements for rolled girders and plate girders

Type of deviation	Figure		Measured length	Permitted deviation	
	No.	Designation		normal	max. ²⁾
Deviation from longitudinal position	85.2-4A	e		± 25 mm	
Deviation from planned lateral position	85.2-4B	e		± 10 mm	
Deviation in height at supports				± 5 mm	
Longitudinal deviation erected girder ¹⁾	85.2-4A		L	± 0.05%	± 50 mm
Straightness deviation erected girder ¹⁾	85.2-1	f	L ³⁾	± 0.07%	± 50 mm
Deviation from given girder distance	85.2-4B		b	± 10 mm	

¹⁾ A deviation of ± 2 mm is permitted irrespective of the length

²⁾ Irrespective of the size

³⁾ Distance between supported points

Type of deviation	Figure		Measured length	Permitted deviation	
	No.	Designation		normal	max. ²⁾
Longitudinal deviation ¹⁾			L	± 0.04%	± 5 mm
Height deviation	85.2-2		h	± 0.16%	
Inclination web	85.2-2	v	h	± 0.6%	
Inclination flange ¹⁾	85.2-2	v ₂	b ₁ , b ₂	± 1.6%	± 15 mm
Inclination end plates ¹⁾	85.2-2	h	b ₁ + b ₂	± 0.3%	
Straightness deviation (sag) ¹⁾	85.2-6	f	L	± 0.07%	± 20 mm
Straightness deviation (curvature) web	85.2-1	v ₃	h	± 0.6%	
Eccentricity web	85.2-2	v ₁	b	± 1.2%	± 10 mm
Deviation camber in partial trial assembly	85.2-8		t	± 5 mm	
Inclination gusset plate	85.2-7	e	L	± 0.4%	

¹⁾ A deviation of ± 2 mm is permitted irrespective of length

²⁾ Irrespective of size

Tolerance requirements for columns

Type of deviation	Figure		Measured length	Permitted deviation	
	No.	Designation		normal	max. ²⁾
Deviation from planned top edge of finished column				± 3mm	
Longitudinal deviation assembled column ¹⁾			L	± 0.4%	
Vertical deviation	85.2-3	e	L	± 0.1%	± 30 mm
Straightness deviation assembled column ¹⁾	85.2-1	f	L	± 0.05%	
Deviation from given column distance at base/top				± 3 mm	

¹⁾ A deviation of ± 2 mm is permitted irrespective of the length

²⁾ Irrespective of size

Type of deviation		Figure		Measured length	Permitted deviation	
		No.	Designation		normal	max. ²⁾
Longitudinal deviation ¹⁾				L	± 0.4%	± 10 mm
Height deviation		85.2-2		h	± 0.16%	± 10 mm
Inclination web		85.2-2	v	h	± 0.6%	
Inclination flanges		85.2-2	v ₂	b ₂	± 1.6%	
Inclination	Steel against steel ¹⁾	85.2-6	h	b ₁ + b ₂	± 0.3%	
End plates	Bridge deck plates to be grouted ²⁾	85.2-6	h	b ₁ + b ₂	± 0.7%	
Inclination gusset plate		85.2-7	e	L	± 0.4%	
Straightness deviation (sag) ¹⁾		85.2-1	f	L	± 0.07%	± 20 mm
Straightness deviation (curvature) web		85.2-2	v ₃	h	± 0.6%	
Eccentricity web		85.2-2	v ₁	b	± 1.2%	± 10 mm

¹⁾ A deviation of up to ± 2 mm is permitted irrespective of length

²⁾ A deviation of up to ± 4 mm is permitted irrespective of length

³⁾ Irrespective of size

Tolerance requirements for frames

Framework columns shall satisfy the requirements in Tables 85.2-3 and 85.2-4. Framework girders shall satisfy the requirements in Tables 85.2-1 and 85.2-2.

Tolerance requirements for trusses

Individual members shall satisfy the requirements in Tables 85.2-2 and 85.2-4.

Type of deviation		Figure		Measured length	Permitted deviation	
		No.	Designation		normal	max. ²⁾
Deviation from planned position	lengthwise	85.2-4	e		± 25 mm	
	sideways	85.2-4	e		± 10 mm	
	in height where supported				± 10 mm	
Longitudinal deviation assembled truss ¹⁾		85.2-5 A		L	± 0.05%	± 50 mm
Deviation from given truss clearance		85.2-4 B		b	± 10 mm	
Straightness deviation assembled truss		85.2-1	f	L	± 0.07%	± 50 mm

¹⁾ A deviation of up to ± 2 mm is permitted irrespective of the length

²⁾ Irrespective of the size

Type of deviation		Figure		Measured length	Permitted deviation	
		No.	Designation		normal	max. ²⁾
Longitudinal deviation ¹⁾		85.2-5		L	± 0.04%	± 10 mm
Height deviation		85.2-5		H	± 5 mm	
Inclination end plates		85.2-6	h	b ₁ + b ₂	± 0.3%	
Straightness deviation (sag)		85.2-1	f	L	± 0.07%	± 5 mm
Deviation from given position, individual member	in-plane	85.2-5	e	H	± 0.15%	
	out-of-plane	85.2-5	e	H	± 0.15%	
Deviation in camber in partial trial assembly		85.2-8		t	± 5 mm	
Inclination gusset plate		85.2-7	e	L	± 0.4%	

¹⁾ A deviation of up to ± 2 mm is permitted irrespective of the length

²⁾ Irrespective of the size

Tolerance requirements for box girders

Box panels shall satisfy the requirements in Tables 85.2-9 and 85.2-10.

Table 85.2-7: Permitted deviation for assembled bridge box girders	
Type of deviation	Permitted deviation
Support points (hanger point, stay anchoring point), position in the longitudinal direction of the bridge, measured along the bridge (total measurement from end or midpoint)	± 20 mm
Total length of bridge (measured along the bridge)	± 50 mm

Table 85.2-8: Permitted deviation for assembled box girders at the fabrication workshop	
Type of deviation	Permitted deviation ¹⁾
Panels, vertical position of corners	± 5 mm
Panels, horizontal position of corners	± 5 mm
Diaphragm at support points (hanger point, stay anchoring point), position in the longitudinal direction of the bridge, measured along the bridge	± 6 mm
Other diaphragms, position in the longitudinal direction of the bridge	± 12 mm
Total length of bridge (measured along the bridge)	± 50 mm

¹⁾ The values are relative to theoretical position on a reference grid. The tolerances apply to both individual sections and to partial trial assemblies at the fabrication workshop.

Tolerance requirements for stiffened plate panels

Table 85.2-9: Permitted deviation for longitudinal and transverse stiffeners					
Type of deviation	Figure		Measured length	Permitted deviation	
	No.	Designation		normal	max.
Web curvature normal to the web plane	85.2-9	f1	L1	± 0.15%	
Web curvature parallel to the web plane	85.2-9	f2	L1	± 0.15%	
Inclination	85.2-9	v4	h	± 3%	± 30 mm
Positioning	85.2-9	v	b	± 1.5%	± 30 mm

Table 85.2-10: Permitted deviation for panels				
Type of deviation	Figure		Measured length	Permitted deviation
	No.	Designation		
Length	85.2-10		L	± 0.1%
Width	85.2-10		B	± 0.1%
Curvature normal to the panel plane	85.2-10	f	¹⁾	± 0.15%
Local buckle in a stiffened plate field		f	1 m	± 3 mm

¹⁾ The lesser of L and B

Tolerance requirements for bolted connections

Maximum alignment deviation between adjacent elements: 1 mm. Packing with a maximum thickness of 5 mm can be used according to special agreement.

Tolerance requirements for weld connections – full penetration butt welds

Maximum alignment deviation: $a < 0.15 t_1$ $t_1 < 3$ mm, where t_1 is the thickness of the thinnest plate. See Fig. 85.2 11. If the alignment deviation is greater, the thickness of the thick plate shall be reduced towards the joint in a ratio of 1:5 so that the requirement is met.

Tolerance requirements for weld connections – transverse joints

Figure		Measured length	Permitted deviation		Condition
No.	Designation		normal	max.	
85.2-12	m	m	$t_1/2$	5 mm	when $t_2 \leq 20$ mm
85.2-12	m	m	$t_1/2$	8 mm	when $t_2 \geq 20$ mm

- x) As in Specification 85.1. Unit: ton

85.21 Preparations for fabrication

- a) Comprises all preliminary work such as preparation of production drawings, bills of materials, welding schedules, templates and jigs. Unless otherwise specified in *the special specifications*, the Project Owner shall prepare drawings and specifications that contain the necessary information on the structure's configuration and geometry, dimensions, materials and connections, so that the contractor can prepare the necessary production drawings and bills of materials.
- c) Production drawings and bills of materials shall be sent to the Project Owner for comment before production starts.
- x) Costs shall be given as a lump sum. Unit: LS

85.22 Tooling and machining of materials

- x) As in Specification 85.1. Unit: ton

85.221 Tooling and machining of rolled steel

- a) Comprises all tooling and machining of rolled steel such as cutting, clipping, sawing, bending, drilling, planing, milling, turning, grinding etc.
- c-e) **Straightening and bending**
All bending and straightening of materials shall preferably be carried out by hot forming (hot bending).

All bending and straightening must be done carefully so that nicks, cracks, curvature and damage to the material do not occur.

Procedures shall be prepared in consultation with the steel manufacturer for hot forming and hot straightening/flame straightening. These shall be submitted to the Project Owner before work starts. The work shall be carried out by qualified personnel. The execution requires close monitoring and recording of the surface temperature of the steel.

Hot forming of thermo-mechanically rolled steel and high-strength steel ($f_y = 420-540$ MPa) is not normally permitted and shall be approved by the Project Owner in each individual case.

Cold-bending may be permitted, but must be carried out in accordance with the steel manufacturer's recommendations. The procedures shall be submitted to the Project Owner before work starts.

Material that has been evenly deformed up to 3% may be used. Aging testing shall be carried out in connection with forming operations that result in deformations in the range of 3-10%. The material requirements for notched bar impact toughness shall be met in an aged condition (10% deformation + heat treatment at 250°C for one hour).

Flame straightening may be permitted in certain cases to remedy warps and misalignments in connection with fabrication. Permission shall be obtained from the Project Owner, and a procedure prescribing temperatures and temperature monitoring shall be submitted for approval for each individual steel grade.

Cutting

Cutting of beams or sheet metal may be done by means of a cutting torch, saw or plate shears. In connection with shearing, all cold-deformed material along the edge shall be removed.

In the case of all slots and embedded corners, holes must be drilled before a cutting torch is used, even if this is not specifically indicated on the drawings. If the hole dimension is not indicated, the diameter of the hole shall be 20 mm. The cutting must be done in such a way that the roundness of the hole is fully used, without creating a stepped transition between the cutting and the hole.

Trimming of ends and edges should be carried out after as much as possible of the welding work on the part concerned has been completed, because of shrinkage.

Tooling and machining of edges, end surfaces and holes

Edges, end surfaces and holes shall be freed of burrs and irregularities by means of planing, milling, grinding or filing. All edges are to be bevelled 2 mm by grinding. Grinding is to be done in the rolling direction.

If the surface is to be metallized, all tempered areas resulting from e.g. torch cutting, must be carefully removed by grinding. Where full-contact bearing is assumed (shall be indicated on the drawing) both surfaces shall be machined so precisely that complete contact is achieved.

Unless otherwise stated in *the special specifications*, $t = 0.2$ mm applies in accordance with NS 1420 as the requirement for planarity.

- x) As in Specification 85.1. Unit: ton

85.222 Tooling and machining of cast steel and cast iron

- a-e) Comprises all tooling and machining of cast steel and cast iron. Repair of surface defects is included in Specification 85.12. For cable sockets of cast steel, see Handbook 122 'Cables for suspension bridges and cable-stayed bridges'. See also *the special specifications*.

- x) As in Specification 85.1 Unit: ton

85.23 Assembly of steel parts

- a) Comprises all putting together, assembly, attachment to the welding bench, mounting on jigs etc. of the separate steel parts or steel elements before final joining is carried out, (welding, bolting together etc.). Also includes all measuring and adjustment in connection with this as well as inspections before the final joining is carried out. Test erection and assembly of structural parts is covered by Specification 85.26. Erection of steel structures at the construction site is included in Specification 85.4.

- c) The assembly shall ensure that the correct geometry of the final product is achieved after joining without subjecting the steel parts to detrimental loads, constraining forces etc. Any assembly steel shall be removed after use as described in Specification 85.42.

- x) As in Specification 85.1. Unit: ton

85.24 Welding

- a) Comprises all work in connection with welding. In addition to the welding itself, this applies to the preparation of welding procedure specifications, performance of necessary production testing and welding procedure tests, cleaning of joints and removal of tack welds, keeping of welding records, application of necessary pre- and post-heating, performance of weld inspection, repairs and post-inspection. The specification applies to fusion welding with an electric arc as heat source.

The supplier shall have a quality control system that satisfies the requirements of NS-EN ISO 3834, part 2.

- b) Powder and filler metal shall be stored in accordance with the electrode supplier's recommendations. See also Specification 85.11

- c) **Preparatory works**

The contractor shall prepare a detailed welding schedule that shows where welding is to be carried out for all major and/or important welds. Routines for storage and handling of powder, filler metal and ceramic backing shall also be prepared. Welding plans and welding procedures shall be submitted to the Project Owner in ample time before work commences.

Welds and weld joints shall be indicated on the drawings in accordance with NS-ISO 2553. Welding procedure specifications shall be prepared for all load-bearing welds in accordance with NS-EN ISO 15609-1. Unless otherwise indicated in *the special specifications*, the welding procedure specifications (WPS) for welds in inspection classes 2 and 3 shall be approved by means of welding procedure testing in accordance with NS-EN ISO 15614-1.

- The test temperature for impact resistance testing shall be in accordance with product standards for the parent metal, cf. Table 85.11-2, and a maximum of 20°C higher than minimum air temperature.

- Notch location for testing in a heat affected zone shall be in the melt border and in the melt border + 2mm.

- Impact resistance testing shall be carried out in the root area for thicknesses > 25mm and always if different filler metals have been used for welding the root and filling the weld.

Hardness measurements shall also be made for materials with a yield strength of ≤ 275 MPa.

- The following requirements shall be met unless otherwise indicated in *the special specifications*:

- Notch impact strength shall be at least equivalent to that of the parent metal in the rolling direction.

- Hardness shall not exceed 325 HV10.

- Macro grinding shall show a weld where each welding bead and heat affected zone can easily be identified. Welding defects of type and dimension are permissible according to the acceptance criteria for Inspection Class 3.

- Fractures as a result of tensile testing across the weld shall take place in the parent metal outside the weld. Tensile strength shall be equal to or greater than the minimum tensile strength specified for the parent metal.

Previously qualified welding procedures may be accepted if they are not more than 5 years old, satisfy the requirements for qualifying welding procedures and are within the qualification range as stated in NS-EN ISO 15614-1, Chapter 8.

The Project Owner shall be notified before the welding procedure test is made so that he may be present. The testing shall be performed at a certified laboratory. For welds in Inspection Class 2, approval may alternatively be given on the grounds of previously approved procedure tests or other independent documentation.

For special welds, where the test pieces specified in NS-EN ISO 15614-1 are not representative of the weld in question, approval of pre-production welding may be used in accordance with NS-EN ISO 15613. For this type of weld, all relevant weld parameters shall be checked, such as effective weld cross-section, root defect, root gap etc. Welding procedure tests and test welds shall be carried out and the results submitted to the Project Owner before production starts.

For welding procedure test requirements regarding notch impact toughness, hardness and macro grinding, see the general requirements for welding work.

General requirements for welding work

All welding work shall be led by an experienced professional welder who can document relevant experience as welding manager/instructor. Only welders who can produce valid welding certificates according to NS-EN 287-1 can participate in the welding work. Approval is required for the position(s) that the work requires.

All load-bearing parts of the steel structure shall be carried out in accordance with the Inspection Class stated in 85 e), unless otherwise stated in *the special specifications*.

Joints shall be executed in accordance with drawings and otherwise in accordance with NS 472. Joints shall be free of dirt, rust, mill scale, paint, grease etc. If the joints have been made by punching, cutting or burning, all cold-formed material and tempered layer after burning shall be removed by grinding.

In fillet welding, the root gap shall be a maximum of 2 mm. If the root gap is larger than 2 mm, but less than 5 mm, it shall be back gouged, cut diagonally and welded with full penetration. The need for pre- and post heating shall be determined by the contractor in consultation with the suppliers or the steel materials and filler metals. See also NS-EN 1011-1 and -2.

Welding work shall be performed in such a way that full control is maintained of weld deformations, and such that the finished structural shape is as given in the drawings. Weld deformations shall preferably be counteracted by laying out the parts to be welded together in advance so that the shape is correct after the welding work is finished and the welds cooled, (see also Specification 85.23). Should corrections to the structure nevertheless be necessary after welding, this shall be done by heat bending, see Specification 85.221.

The area around the welding place shall be free of moisture. The welding place shall be protected against wind and drafts. Welding is not permitted at ambient temperatures lower than + 5°C.

The lowest permitted material temperature is 30°C. This temperature shall be established in an area with a width of 75 mm on both sides of the centre line of the weld.

Each welding bead and the finished weld shall be deslagged and cleaned carefully.

For welds in Inspection Classes 2 and 3, tack welds shall be removed. Tack welds can however be allowed to remain as a permanent part of the main weld if they have been carried out by qualified welders under the same conditions as the root bead/main weld. The contractor shall submit qualified procedure tests carried out with tack welds. The beginning and end of tack welds that remain shall be ground smooth.

The electrode shall not be ignited outside the welding groove. Should this nonetheless happen, ignition marks shall be removed by grinding. Magnetic particle inspection may also be required in the areas concerned.

Any requirements for grinding of welds shall be indicated on drawings or in *the special specifications*.

Unless otherwise stated in *the special specifications*, the finished welds shall meet the requirements for qualification of weld procedures.

Special requirements for welding trapezoid sections to the bridge deck plate

Unless otherwise stated in *the special specifications*, the weld shall be made as a partial V weld with a remaining root gap (incomplete weld penetration) 0-2 mm, see Fig. 85.24-1

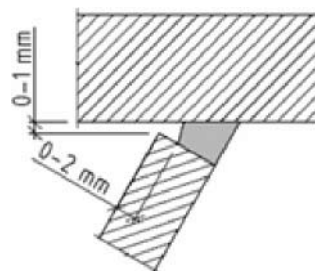

Figure 85.24-1

The gap between the trapezoid section and the cover plate should be ≤ 1 mm. Backing in full penetration butt welds shall not be tack welded outside the weld joint of the main weld.

Special requirements for welding of bolt studs

Unless otherwise indicated in *the special specifications*, welds shall be made with full weld penetration in accordance with the supplier's specifications. Fillet welds of bolt studs are not allowed without special permission from the Project Owner. Weld repairs shall be carried out according to approved procedures.

Acceptance limits for welds

Limits for the individual defects and combined defects that are acceptable are defined below. If the limits are exceeded, the defects shall be reported to the Project Owner before repairs are commenced.

Repeated findings of defects exceeding acceptance limits and findings of planar defects shall result in an increase in non-destructive testing of connections, a review of welding execution and weld inspections, and if relevant a revision of welding procedures.

Fault indications that may be planar, but due to difficult geometry or other circumstances are difficult to interpret, shall lead to a review of the inspection method with a view to finding a better method if possible. Repeated systematic defects are not permitted.

Acceptance limits for visual inspection

- Welds shall have an even surface and a smooth transition to the parent metal.
- Fillet welds should be symmetrical and have a slightly concave or planar surface.
- Butt welds shall not have weld metal in excess of than indicated in Table 85.24-1.

Plate thickness	Max. excess weld metal
$t \leq 10$ mm	2 mm
$10 \text{ mm} < t \leq 25$ mm	3 mm
$25 \text{ mm} < t \leq 50$ mm	4 mm
$50 \text{ mm} < t$	5 mm

- All welds shall have an even transition to the parent metal without sharp edges.
- the a value (throat thickness) for fillet welds is determined in accordance with Figure 23 in NS 3472.
- Weld unevennesses shall not be greater than 2 mm.

The weld shall also satisfy the following requirements:

Type of defect	Inspection Class 1:	Inspection Class 2:	Inspection Class 3:
Cracks	Not allowed	Not allowed	Not allowed
Incomplete weld penetration or bonding defect	On the root side of the weld where root welding is not required: length $< t/2$, max. 10 mm, min. distance t. Not permitted on the surface	Not allowed	Not allowed
Surface porosity	Not allowed	Not allowed	Not allowed
Undercut (max. depth) ¹⁾	1 mm	0.5 mm	Not allowed
Alignment deviation	$\leq 0.15 t$	$\leq 0.15 t$	$\leq 0.15 t$

¹⁾ Depth shall be measured with mechanical equipment

Acceptance limits for magnetic particle inspection

Type of defect	Inspection Class 1:	Inspection Class 2:	Inspection Class 3:
Cracks	Not allowed	Not allowed	Not allowed
Incomplete weld penetration or bonding defect	Not allowed on the surface	Not allowed	Not allowed
Surface porosity	Max. pore diameter $t/4$, max. 4 mm	Not allowed	Not allowed

Acceptance limits for x-ray inspection

Table 85.24-4		
Type of defect	Inspection Class 1:	Inspection Class 3:
Inner porosity ^{1) 2)}		
Individual pores:		
Max. pore diameter, mm	t/4, max. 6	t/5, max. 4
Collection of pores:		
Max. pore diameter, mm	3	3
Tubular pores:		
Max. length of projected area, mm	25	20
Max. accumulated pore diameter in an area 10 × 150 mm	20	15
Slag inclusions ^{1) 3) 4) 5)}		
Isolated slag:		
Max. width, mm	t/4, max. 6	t/5, max. 4
Max. length, mm	2 t	t
Slag lines:		
Max. width, mm	2 ⁶⁾	1.5 ⁶⁾
Max. length, mm	4t, max. 100	2t, max. 50
Incomplete weld penetration ^{3) 4) 5)}		Unacceptable where complete weld penetration is required
Max. length, mm	t, max. 25	
Bonding defect ^{3) 4) 5)}	Not allowed	Not allowed
Cracks	Not allowed	Not allowed

¹⁾ If porosity or slag inclusions are assumed to hide certain detection of other defects, supplementary tests using other methods shall be carried out.

²⁾ If more than one pore is located within a 12 mm diameter circle, the pores shall be considered as a collection of pores.

³⁾ If several defects stretching lengthwise are located in a line and the distance between them is less than the length of the longest indication, the defects shall be considered a continuous defect.

⁴⁾ All groupings of slag inclusions, incomplete burning or bonding defects shall be assessed as the least favourable defect.

⁵⁾ Defects that according to the table are permitted shall not occur in continuous welds that are less than 5L, where L is the length of the defect being considered.

⁶⁾ The width of each parallel slag line shall not exceed the indicated value.

Acceptance limits for ultrasound inspection

Table 85.24-5	
Inspection Classes 2 and 3	
Acceptance criteria in accordance with DNV Classification Note No. 7 – Non-destructive Testing, Rev. December 2004, point 6.9	

Comments to the table:

- The operator shall investigate all indications over 20% of the reference height to the extent that the size, shape and position of the defect are established, and he shall evaluate the defect against the acceptance limits for x-ray inspection.

- Indications that, due to his experience or knowledge of the welding method and weld geometry, the operator assumes to be cracks or bonding defects, shall be disallowed irrespective of the height of the echo.

- In the case of lengthwise defects where the echo height is partly over and partly under the reference curve, the entire length shall be repaired.

- The length of a defect is defined as the total repaired length.

Repairs

Repair work shall only be carried out after approval from the Project Owner.

The contractor shall send written repair procedures to the Project Owner for approval. The specifications shall contain methods for eliminating defects, seam design etc. The specifications shall if necessary contain new, qualified welding procedures.

Welded connections that contain defects after the welding has been carried out shall be repaired as follows:

- All defects shall be carefully removed

- The repair area shall be subjected to magnetic particle inspection to ensure that all defects have been removed.

If more than 7% of the material thickness or 3 mm is removed, whichever is the smaller value, the repair shall be carried out as follows:

- Repair welding shall be carried out in accordance with the approved procedure.

- The repair weld seam shall have a regular shape and be free of rust, grease, oil or other contaminants. After torch cutting or carbon arc chiselling, the repair area must be ground so that it is free of all carbon-contaminated parent metal. The minimum repair length is 100 mm.

- The repair area plus 100 mm on each side shall be subjected to magnetic particle inspection to ensure that all defects are removed before the repair welding begins. Magnetic powder shall be removed by grinding after the testing.

- The pre-heating temperature shall be 50°C higher than for normal welding. The pre-heating temperature shall be established in an area larger than twice the plate thickness, but not less than 150 mm along each side of the weld, and the temperature shall be maintained until welding is finished. The area that is repaired shall be inspected visually and 100% non-destructive testing shall be carried out with relevant methods.

e) **General**

The contractor undertakes to perform a careful internal control throughout the work, directed by an experienced professional welder. For all welds in Inspection Class 3 and 2, or in the cases where this is specially agreed, the contractor shall keep a record of all welding work. The records shall contain the following information:

- Weld location (on the structure)
- Name of the welder
- Date/time of the welding
- Welding procedure specifications used
- Parameters that may vary in relation to the procedure specifications, such as root measurement, temperature, plate thickness or other differences that are specially agreed.

The contractor shall maintain ongoing monitoring of welding work in the form of visual inspection and tests using x-ray and/or ultrasound and magnetic particle inspection etc. to detect any cracks, pores, bonding defects, slag inclusions, undercuts, root defects etc. The extent of the monitoring depends on the inspection class and shall be in accordance with the table below, unless otherwise indicated in *the special specifications*. In the case of welded connections with less than 100% inspection cover, inspections shall be carried out in areas where the likelihood of defects is assumed to be greatest.

Inspection class	Type of connection	Visual inspection	X-ray ^{7) 8)}	Ultrasound ^{4) 8) 10)}	Magn. powder
1	All welded connections	100%	-	-	spot checks ^{5) 6)}
2	Full penetration butt weld	100%	5% ^{1) 2)}	20% ³⁾	20%
	T-connection full weld penetration	100%	-	20%	20%
	Fillet weld/partial butt weld	100%	-	-	20%
3	Butt weld	100%	10% ^{1) 2)}	100% ³⁾	100%
	T-connection full weld penetration	100%	-	100% ⁹⁾	100%
	Fillet weld/partial butt weld	100%	-	-	100%

- 1) One film at each cross-section between longitudinal and transverse welds.
- 2) Film of welds around the circumference of tubular sections shall contain the start and stop of the welding. If the start and stop locations are not known, a 100% inspection shall be made.
- 3) If during the ultrasound testing uncertain welding defects are discovered, these shall undergo supplementary x-ray inspection.
- 4) Applies to plate thicknesses from 10 mm and up.
- 5) Spot checks minimum 5%.
- 6) A minimum of 20% all external welds whose purpose is to permanently seal closed spaces shall be subjected to magnetic particle inspection.
- 7) X-ray inspections shall be replaced with ultrasound for material thicknesses greater than 40 mm.
- 8) Site butt welds shall be 20% inspected by x-ray and 100% inspected with ultrasound.
- 9) A laminating test shall be performed in a zone of 75 mm on each side of the weld's centre line.
- 10) Ultrasound shall be replaced by X-ray for material thicknesses of ≤ 10 mm. Applies to butt welds. The Project Owner will make spot checks.

Trapezoid sections in the bridge deck plate

Unless otherwise indicated in *the special specifications*, the welding of trapezoid sections in the bridge deck plate shall be monitored by conducting production tests. The production tests shall be carried out during normal production and as a direct extension of the structure concerned without stopping or adjusting welding parameters. The number of production tests is normally indicated in *the special*

specifications. If it is not indicated, one production test shall be carried out for each 100 m trapezoid section at the start of production. When the process attains satisfactory quality, the number of tests can be reduced to one test each 200 m. Reduction of the scope of testing shall only take place after a request is submitted to the Project Owner. The request shall contain statistics on the test results. Welding parameters shall be recorded and hardness tests and macro-grinding shall be carried out in accordance with NS-EN ISO 15614. All relevant geometrical conditions shall be checked, such as remaining root gaps (incomplete weld penetration), effective weld cross-section and transition to the parent metal. The sample shall be bent to open the weld root for inspection.

Circular and rectangular and hollow sections

Circular and rectangular and hollow sections that are used in the structure with dimensions such that they cannot be surface-treated on the inside shall be air-tight. Such elements shall be pressure tested and withstand at least 50 kPa overpressure. The contractor must carry out 100% pressure testing of these with welds coated with soapy water, or 100% magnetic particle inspection of the welds.

Such pressure testing is unnecessary for closed internal stiffeners inside box cross-sections with dehumidification facilities, but drainage must be ensured in the box cross-section at the lowest point (normally at the supports).

The Project Owner will carry out spot tests.

Bolt studs

Unless otherwise indicated in *the special specifications*, 5% of the bolt studs shall be tested. Testing shall take place by bending the bolts 15° by hitting them on the side of the head with a hammer. The weld shall show no signs of cracks or incomplete weld penetration (special sound). The bolts shall not be straightened after testing. Studs that do not meet the requirements shall be replaced. The procedures for replacement shall be submitted to the Project Owner for comment.

Documentation

All non-destructive testing (NDT) shall be documented so that the areas inspected can easily be identified and so that the test documentation can be easily reproduced. The documentation shall identify and locate weld defects and determine whether they are within or outside the acceptance criteria. Weld defects shall be indicated on sketches that show location both along the welds and in the weld cross-section.

For ultrasound inspection, all echoes that exceed 50% of the reference height for Inspection Class 2 and 20% for Inspection Class 3 shall be reported. The report shall contain the position of the weld defect, echo height, length, depth below the surface and type of defect. Should it not be possible to ascertain the type of defect with certainty, the probable defect type shall be indicated.

Execution

Non-destructive testing (NDT) of welds shall not be carried out earlier than 24 hours after the work has been done. General requirements for NDT of welded connections are indicated in NS-EN 12062.

X-ray inspection shall be carried out in accordance with NS-EN 1435. For welds in Inspection Classes 3 and 2 with thicknesses of > 25 mm, Class B techniques shall be used. For other welds, Class A techniques are acceptable. Ultrasound inspection of weld connections in plates shall be carried out in accordance with DNV Classification Note No. 7 – Non-destructive Testing, revision December 2004.

Ultrasound testing of tubular joints can be carried out in accordance with API RP 2X, according to agreement with the Project Owner.

Magnetic particle inspection shall be carried out in accordance with NS-EN 1290. AC yokes should be used. If the prods method (direct current throughput) is used, care shall be taken to avoid local heating of the test surface. Lead coated or soft electrodes shall be used. The contractor shall prepare procedures for all NDT and submit these to the Project Owner for approval.

Personnel

The necessary qualifications for personnel that perform welding inspections and non-destructive testing shall be documented.

Personnel who perform welding inspections shall be qualified in accordance with NS 477/IWI/EWI or an equivalent recognised standard, or be able to document equivalent qualifications.

Personnel who perform non-destructive testing shall be certified in accordance with EN 473 or the equivalent. The certification level depends on the work to be performed, but shall normally be level II for operators and III for personnel who prepare procedures and who have ultimate responsibility for the inspection work.

- x) As in Specification 85.1. Unit: ton

85.25 Bolted connections

- a) Comprises all use of bolts.
- b) See Specification 85.13
- c) **General**

The bolt shall be long enough for it to be possible when bolts are inserted manually (loose screwing) to screw the nuts on completely (full nut engagement) with at least one complete thread pitch protruding.

The bolt head and nut must engage fully with the plate surface and washer, if any. If necessary, a non-planar washer and nut lock shall be used. All gusset plates, splices, packing etc. shall have full engagement.

All holes shall be drilled. Holes shall only be punched with the approval of the Project Owner in each individual case.

The individual steel components must be pre-drilled before assembly with a hole diameter of about 3 mm less than the specified dimension. In some cases, where the contractor's working methods result in high precision, the Project Owner may permit a reduction in the difference. Broaching to the final diameter shall take place while the structure is lying assembled at the fabrication workshop unless otherwise specified in *the special specifications*. During broaching, the individual parts shall be so firmly held together by bolts and mandrels that flexing or displacement does not occur. The holes must be smooth and clean, with axes normal to the plate surface. If clean holes are not achieved through normal broaching, broaching shall according to agreement be taken to the next bolt diameter size, and correspondingly larger bolts used. After final broaching, the edges of the hole shall be bevelled.

In the case of bridge components that are not pre-assembled, final broaching shall take place during site assembly.

Before the bolts are inserted, the Project Owner shall be notified for inspection of the bolt holes.
Bearing-type (shear) connections, pre-loaded and non-preloaded bolts in normal holes

The hole diameter shall be a maximum of 1.6 mm larger than the bolt shaft diameter. It shall be possible to insert the bolts manually without hammer blows or similar. Non-pre-loaded bolts in normal holes shall not be used in load-bearing parts of the structure.

After a connection has been fully assembled, all bolts shall be gone over again and tightened well. Non-pre-loaded bolts shall be locked with centre marks by means of an appropriate centre punch or chisel blows flush with the top of the nut.
Pre-loaded bolts do not need any further locking.

Bearing-type connections, fit bolts

The hole diameter shall be a maximum of 0.2 mm larger than the bolt shaft diameter.

It must be possible to drive in the bolts with light blows. The thread length shall be fitted such that the part of the shaft that corresponds to the grip length is without thread. Washers shall therefore be used under the nuts. After completion of the assembly, all bolts must be tightened and locked as described for bolts in normal holes.

Slip-resistant connections (friction connections)

The hole diameter shall be $d + 1$ mm for M12 and M14, $d + 2$ mm for M16 up to and including M24 and $d + 3$ mm for M27 and larger.

It shall be possible to insert the bolts manually without hammer blows or similar. There shall be a washer under both the head and the nut.

There shall be a minimum of 4 threads on the inner side of the nut. There shall be at least 1 complete thread pitch outside the nut after pre-loading.

All contact surfaces and all splices and packings in slip-resistant connections shall be blast cleaned and metallized and have tie-coat sealer applied, but shall not be painted. The metal coating shall be a minimum of 30 μ m, max. 50 μ m thick unless otherwise indicated in *the special specifications*. If paint gets onto the contact surfaces, it shall be removed by blast cleaning followed by metallizing. It shall be ensured that grease and other contaminants do not get onto the friction surfaces during moving around, transport and assembly. Contaminants may only be removed by blast cleaning. If the friction surfaces are attacked by white rust, this must be removed. Friction surfaces in assembly connections shall be protected (wrapped up) during transport and storage. The bolts shall be pre-loaded as specified below.

Pre-loading of bolts

Tightening of a slip-resistant connection to a specified pre-loading force (proof load) shall be carried out according to one of the methods given below, see NS 3464 and NS-EN 14399-2. Unless otherwise indicated in *the special specifications*, the combined method shall be used.

- torque method
- load-indicating method
- combined method

Before tightening according to one of these methods, the bolt connection shall be pre-tightened to full contact between the plates. The pre-tightening load shall be at least $\frac{1}{4}$ of the specified pre-loading force. Tightening shall start in the centre of the bolt group and continue outwards. If necessary, this tightening shall be repeated to take up all internal gaps in the connection. Tightening can normally be achieved by using an air ratchet until the tool begins to deliver blows.

When tightening equipment that has to be calibrated is used, the calibration shall take place at least once per shift, when the property class is changed and when the bolt size is changed.

A calibrated torque wrench is used for the torque method. The torque wrench shall be calibrated with a precision of $\pm 5\%$.

The torque wrench shall be set to at least the torque that is necessary to achieve the pre-loading force. This torque is determined through calibration tests carried out on a tensile testing machine with a selection of the bolts that are used in the connection (bolt with lubricant, washer and nut). A representative test shall consist of a minimum of 6 bolts of each size and property class that is to be used.

After pre-tightening, the connection shall be tightened with the pre-set torque wrench, starting in the centre and working outwards. The tightening is repeated according to the same pattern until all bolts are fully tightened.

The load-indicating method involves use of load-indicating tightening tools that record the tension in the bolt. Equipment based on torsion is not permitted.

The tensioning tool shall be calibrated in the same way as for the torque method by testing a minimum of 6 bolts of each size and property class in a tensile testing machine.

After pre-tightening, the connection shall be tightened to the pre-loading force, starting at the centre and working outwards. If necessary, the tightening shall be repeated until all the bolts have reached the pre-loading force.

When the combined method is used, after pre-tensioning, all bolts shall be tightened with a pre-set torque wrench until 2/3 of the specified pre-loading force has been reached. The torque wrench shall be calibrated as in the torque method.

The position of the nut in relation to the bolt shaft shall be marked and final tightening to the pre-loading force carried out by turning the nut at least the angle necessary to achieve the pre-loading force.

This angle is determined through tests carried out with a calibrated torque wrench in a tensile testing machine with a selection of the bolts that are used in the connection (bolt with lubricant, washer and nut).

The relationship between rotation angle and torque applied shall be recorded. A representative test shall consist of a minimum of 6 bolts for each size and property class that is to be used.

Normal values for the rotation angle may vary from 60° to over 120° depending on the thickness of the connection.

- e) The bolts shall be checked according to the table below:

Inspection Class	Before assembly	After assembly	
	Test in tensile testing machine	Visual inspection	Test with torque wrench
1	-	20%	-
2	Pre-testing	100%	5%
3	Pre-testing	100%	100%

Pre-testing

Before bolts for slip-resistant connections are used, a suitable selection with the chosen lubricant shall be tested by the contractor. Unless otherwise specified in *the special specifications*, at least 6 of each size, length, property class and manufacturing series shall be tested with nut and washer.

In all methods used, the bolts must have sufficient deformation capacity. The deformation requirements are:

- After the bolts have been tightened to the pre-loading force, the position of the nut in relation to the bolt shaft shall be marked and the nut turned until maximum load has been achieved. The rotation shall be at least 60°. Testing shall be carried out in the tensile testing machine with a calibrated torque wrench.

- The bolt assembly shall be turned further until failure (thread stripping or fracture). The rotation shall be at least 180° from the pre-loading force position.

The relationship between tensile strength, torque and rotation angle shall be recorded. It shall be decided whether the lubricant is satisfactory, i.e. that the torque load in the bolt shaft is not too large.

The bolts shall not be used before the result of the testing has been approved by the Project Owner.

Visual inspection after assembly

For visual inspection, bolt and nut shall be marked after pre-loading and before tightening so that the tightening angle can be determined.

Test with torque wrench

It shall be tested with a calibrated torque wrench that the pre-determined torque has been achieved. The torque wrench shall be calibrated as in the torque method.

- x) Unit: kg

85.26 Partial trial assembly

- a) Comprises test assembly and fit-up of structural members.
- c) Partial trial assembly/fit-up of all major structural members shall be carried out at the fabrication workshop unless otherwise indicated in *the special specifications*.

The main purpose of the partial trial assembly is to ensure the correct geometry for the completed bridge. It must be planned in such a way and have such a length that this is achieved. All site welds for the main girders shall be trial-assembled.

The fit-up shall take place on a solid base. The support points shall be placed such that no unnecessary forces are imposed on the structure. The structure shall not have external forces imposed on it in either horizontal or vertical trial assembly, (shall lie without stresses).

In the case of plane trusses and straight steel plate girders, trial assembly may take the form of planar trial assembly, unless otherwise indicated in *the special specifications*. Complete or partial trial assembly in 3D may also be required. For bolted connections that cannot be assembled at the fabrication workshop, broaching of holes to full size shall take place during site assembly.

Plate girders and box girders that are fabricated in sections that are to be welded together during site assembly shall be set out at the fabrication workshop so that welding seams in the site weld can be fitted and the geometry checked. Account shall be taken in the fit-up of expected welding shrinkage.

Any assembly fittings shall be adjusted in the test assembly so that the geometry can be re-established at the bridge site. In complex 3D structures the contractor shall prepare a plan for fit-up and for geometrical measurements of the trial assembly. A system of coordinates (setting out marks) shall be established for registrations.

- e) All geometrical measurements shall be documented and any deviations marked. The measuring report shall be submitted to the Project Owner before he carries out his inspection.
- x) As in Specification 85.1. Unit: ton

85.3 Surface treatment of steel structures

- a) Comprises cleaning of the steel surface, delivery and application of coating and patching and repair of surface treatment after site assembly. The specification also includes all washing/degreasing, hosing and other cleaning and removal of dust and contaminants etc.

Supplementary painting after site assembly is included in Specification 85.43.

- b) Corrosion-protection system for untreated steel surfaces is described below. The system is a duplex system consisting of a cathodic protection metal coating and paint.

The choice of corrosion-protection system shall be made by the Project Owner. Unless otherwise indicated in *the special specifications*, system 1 with thermally sprayed zinc shall be used.

System 1. Metallizing plus epoxy/polyurethane (duplex system)

Pre-treatment: If necessary alkaline wash, degreasing and hosing with clean freshwater.

Blast cleaning: Grade: Sa3

Roughness: Medium G, Ry5= 50-85 µm

Coating system:

1. Minimum 100 µm pure, thermally sprayed zinc
2. 25-30 µm epoxy polyamide tie-coat sealer
3. 100-125 µm epoxy mastic
4. 60-100 µm polyurethane or polyurethane acryl

The thickness of the last coat shall be chosen in accordance with the manufacturer's instructions for the paint type in question (see technical data sheet).

Total coating thickness: Minimum 285 µm. All thicknesses stated are dry film thicknesses.

For maintenance systems see Specification 88.48.

Each coat shall have a different colour. The colour code of the last coat shall be indicated in *the special specifications*.

The various paint products and any additives, thinners etc. to be used shall be from the same supplier. The supplier shall deliver technical data sheets containing the following information:

- Pre-treatment requirements
- Volume % solid matter
- Wet/dry film thickness (max./min. specified)
- Over-painting intervals at 5°, 10° and 23°C (max., min.)
- Recommended thinner (quantity and type)
- Theoretical covering capacity
- Application recommendations/requirements

Paints in coating system 1 shall be pre-qualified according to ISO 20340 Procedure A. Paints that satisfy the requirements in NORSOK M-501, System no. 1 are pre-qualified. (Zinc-rich primer is replaced in the coating system by thermally sprayed zinc and tie-coat).

Table 85.3-1: Acceptance criteria for paint system in coating system 1	
Test	Acceptance criteria
ISO 20340	Acceptance criteria specified in ISO 20340 apply. Also applicable: Adhesion over 5 MPa before test and less than 50% reduction after test (NS-EN ISO 4624) Chalking: Rating 2 or less (NS-EN ISO 4628-6) Over-paintable with top coat after testing without mechanical treatment of surface. Adhesion at least 5 MPa (NS-EN ISO 4624).

Tie-coat sealer shall be of the type two-component unpigmented epoxy polyamide. In addition to pre-qualification, documentation is required of considerable experience with the coating system with respect to corrosion protection effect, general degradation and over-paintability with maintenance coats.

The Project Owner nonetheless reserves the right to reject pre-qualified systems on the basis of negative experiences with own structures or those of others.

All paint products and solvents shall be stored in their original packaging and shall bear the supplier's guidelines. The manufacturing number and use-by date shall be shown on all containers.

- c) The contractor shall prepare detailed procedures for applying the coating. The procedure shall be submitted to the supplier for approval. The procedure shall be forwarded to the Project Owner for comments.

The application of all systems shall be in accordance with the following general specifications and the suppliers' technical data sheets. Should there be disagreement between the specifications and the data sheets, the Project Owner shall be informed and a choice made in consultation with the supplier.

General requirements concerning execution

Unless otherwise indicated in *the special specifications*, the surface treatment, with the exception of patching after site assembly and possibly the final coat, shall be completed at the fabrication workshop or under cover before site assembly. To avoid corrosion of steel and white rust on zinc, blast cleaning and the application of thermally sprayed zinc and paint system shall take place without transport or interim storage out of doors or in damp surroundings and with as little time as possible between operations.

In applying the paint system, the individual work operations shall be completed within the time frame recommended by the paint supplier. The surface treatment shall as far as possible be completed before the individual components are assembled, so that all components receive the prescribed treatment.

If necessary, the surface shall be washed/degreased with an alkaline detergent and hosed with clean freshwater so that all contaminants (oil, grease, salts, detergent etc.) are removed. If the surface is heavily polluted by welding smoke, chemicals, greasy substances with low solubility etc., the contractor must prepare special cleaning procedures. These shall be submitted to the Project Owner for comment.

All blast cleaning, metallizing and painting shall take place at temperatures above 5°C. Relative humidity shall be less than 70% for blast cleaning and metallizing and lower than 80% for painting. The temperature of the steel shall lie at least 3°C above the dewpoint when metal coating and primer are applied, and at least 2°C above it for subsequent coats.

Steel surfaces that are to receive surface treatment shall be blast cleaned. Painted or metallized surfaces that have become contaminated shall be thoroughly cleaned before a new paint coat is applied, see Specification 85.33.

All personnel who carry out surface treatment shall be qualified machinery and industrial painters (Norwegian trade certificate (fagbrev for maskin- og industrimaler) or equivalent). Unskilled personnel shall only take part following individual advance approval by the Project Owner.

Site welding

In the area surrounding a site weld, the various layers (blast cleaned surface, thermally sprayed zinc, paint) shall be reduced stepwise by about 100 mm, one layer at a time. Masking should not be used, as this will result in distinct transitions. All flash material at the transitions between the different layers shall be evened out through light scraping with a glass sheet or light grinding. There shall be at least 100 mm bare steel on each side of the joint. When the joint zones have been blast cleaned after welding, the transition between metal and cleaned steel shall be scraped with a glass plate or ground to remove irregularities in the thermally sprayed zinc. Then the surface treatment of the joint zones shall be built up as elsewhere on the structure.

For surface treatment of friction surfaces in slip-resistant connections, see Specification 85.25.
Repair of surface treatment

White rust on thermally sprayed zinc shall be removed before over-painting. If the white rust cannot be removed without damaging the metallizing, the steel shall be blast cleaned to Sa 3 and metallizing repeated.

If the paint coating should be damaged, the edges must be sanded down and the area cleaned before it is re-painted with the number of coats that have been damaged (with spray for large repairs and a brush for smaller areas). If the damage is on an edge, corner etc. and the repair is carried out by spraying, it shall also be painted locally with a brush between coats (stripe coats).

If the thermally sprayed zinc is damaged, the area shall be cleaned and the damage repaired with zinc-rich primer as specified for Maintenance System 2 in Specification 88.48. Epoxy tie-coat sealer is then applied, and the same paint system as the rest of the bridge. Major damage, i.e. damaged areas larger than 50 x 50 mm, shall be blast cleaned to pure steel and remetallized.

- e) Inspection shall be carried out in accordance with the inspection schedule drawn up by the contractor. Persons responsible for inspection and verification of inspection work shall be qualified in accordance with NS 476 "Regler for godkjenning av inspektører for overflatebehandling" (Rules for approval of inspectors for surface treatment). The inspector shall be able to document relevant practice and knowledge corresponding to NS 476.

All factors at the manufacturing/building site that affect the quality of the surface treatment, such as wind and weather, temperature, air humidity, dewpoint, steel temperature, etc., must be recorded at least twice per shift and always when conditions change substantially. Records must be kept and sent to the Project Owner on request.

The contractor must have at least the following standards and equipment available for inspections:

- NS-EN ISO 8501-1 (Atlas for visual assessment of surface cleanliness)
- Tape test equipment (NS-EN ISO 8502-3)
- Bresle test equipment (NS-EN ISO 8502-6)
- ISO Surface profile comparator (NS-EN ISO 8503-1)
- Magnetic dry film thickness gauge
- Wet film thickness gauge
- Hygrometer/Psychrometer
- Air thermometer
- Steel surface thermometer
- Dewpoint calculator
- Tape - ASTM D3359
- Sharp, thin knife
- Microscope with light, 30x
- Inspection mirror
- Adhesion tests (NS-EN ISO 4624)

Adhesion shall be checked at individual points for thermally sprayed zinc and for paint between coats when the paint system has dried and hardened. Adhesion should preferably be measured on separate sample plates that are pre-treated and coated in parallel with the actual structure. Adhesion shall be measured according to NS-EN ISO 4624 Pull-off test. Adhesion for thermally sprayed zinc measured during manufacturing shall be at least 3.5 MPa and for paint at least 2 MPa. Damage after adhesion tests shall be repaired.

Before applying tie-coat, thermally sprayed zinc shall be inspected visually for damage, unevenness and occurrences of white rust (zinc oxide and zinc hydroxide).

Wet film thickness shall be checked regularly during application. Unless otherwise indicated in *the special specifications*, dry film thickness shall be checked for each coat and for the total paint/coating system. Each coat of paint shall be inspected visually for untreated patches, mechanical damage, pinholes etc.

Inspection shall be carried out as specified in Table 85.3-2 unless otherwise indicated in *the special specifications*.

Inspection class	Surface	Visual inspection 1	Adhesion test ¹⁾	Thickness test
2	Large plane surfaces without stiffeners ²⁾	100%	One test per 40 m ² of surface.	One test per 20 m ² of surface.
	Large plane surfaces with stiffeners ³⁾	100%	One test per 20 m ² of surface.	One test per 10 m ² of surface.
	Small surfaces or complex geometry ⁴⁾	100%	One test per 10 m ² of surface and at least one for every 10 components. ⁵⁾	One test per m ² of surface and at least one per component. ⁵⁾
3	All surfaces	100%	One test per m ² of surface and at least one for every 5 components. ⁵⁾	4 tests per 10 m ² of surface and at least 4 tests per component. ⁵⁾

¹⁾ Extent as specified below unless otherwise indicated in *the special specifications*. Destructive adhesion tests may, according to agreement with the Project Owner, be carried out on special test plates that are coated in parallel with the work itself.

²⁾ External boxes and large webs, plate girders

³⁾ Ordinary plate girders

⁴⁾ Truss members and complex stiffener arrangements etc.

⁵⁾ A completed unit from the fabrication workshop which is to be assembled at the bridge site etc. (truss member, diaphragm, beam etc.) is regarded as a component.

Thicknesses are to be checked with a magnetic thickness gauge according to NS-EN ISO 2178. The gauge shall be calibrated every four hours of use with the aid of foils in the thickness range in question. Calibration shall take place on a plane surface and 20 µm shall be subtracted from the values that are measured for coating on blast-cleaned surface unless otherwise indicated in *the special specifications*.

Every point measurement is an average of three measurements 100 mm apart. No point measurement, i.e. the average of three measurements, shall be less than 90% of the specified thickness.

Example of readings:

Description of coating/thickness	Readings calibrated on blast-cleaned surface	Readings calibrated on face ground surface
Zinc, min. 100 µm	Min. 100 µm	Min. 120 µm
1st coat paint, min. 25 µm	Min. 125 µm	Min. 145 µm
2nd coat paint, min. 100 µm	Min. 225 µm	Min. 245 µm
3rd coat paint, min. 60 µm	Min. 285 µm	Min. 305 µm

The readings shall be recorded. Records shall be kept and sent to the Project Owner on request.

- x) Quantity shall be measured as the total of the parts of the surface of the steel components that is to receive surface treatment. The surface shall be calculated for each item number in the bill of materials, without deductions for holes and without additions for bolt connections etc. Unit: m²

85.31 Qualification of work procedures

- a) The specification comprises qualification of work procedures before the work starts.
- b-c) Procedure tests shall be carried out on test plates with a minimum size of 0.5 m². If more than one system is to be used, at least one test shall be carried out with each system.

The scope of the test procedures shall be described in *the special specifications*.

All work procedures shall be carried out on the actual site, and at least one test shall be carried out before the work starts, and then one monthly for the duration of the contract.

The Project Owner can require that the contractor carry out further procedure tests if the circumstances indicate they are necessary. The contractor shall have the results available for the Project Owner at all times.

- e) Records shall be kept and inspections/checks carried out as described in 85.3.
- 100% visual inspection after each work operation. A special check shall be made to ensure that no pinholes occur in a coat of paint. This applies in particular to sealer/tie-coat on thermally sprayed zinc.
 - Cleanliness according to NS-EN ISO 8501-1.
 - Cleanliness according to NS-EN ISO 8502-3, tape test. One test per sample
 - Cleanliness according to NS-EN ISO 8502-6 (Bresle method). One test per sample.
 - Roughness according to NS-EN ISO 8503-1. One test per sample

- Adhesion according to NS-EN ISO 4624 Pull-off test. One test per sample
- Dry film thickness. Three measurements per sample.

x) Quantity shall be measured as the number of procedure tests. Unit: pcs

85.32 Degreasing and washing

a) Comprises cleaning of steel surface to remove oil, grease, salts etc. and hosing with clean freshwater.

The specification applies only to first-time cleaning on taking delivery of steel. Any repeat cleaning because of new contamination shall be included.

The specification is not used when the contractor is responsible for procurement, transport and handling of the steel. In such case all necessary cleaning shall be included in other specifications.

b-c) The surface of the steel shall be degreased/washed with an alkaline detergent and hosed with clean freshwater so that all contaminants (oil, grease, salts, detergent etc.) are removed.

If the surface is heavily polluted by welding smoke, chemicals, greasy substances with low solubility etc., the contractor must prepare special cleaning procedures. These shall be submitted to the Project Owner for comment.

x) As in Specification 85.3. Unit: m²

85.33 Blast cleaning

a) Comprises blast cleaning of the steel surface with a metallic or non-metallic blasting abrasive.

b) Metallic blast-cleaning abrasives shall have properties as defined in NS-EN ISO 11124. Non-metallic blast-cleaning abrasives shall fulfil the requirements in NS-EN ISO 11126. The blasting abrasive shall be chosen so that the specified roughness and cleanness is obtained.

c) Blast cleaning shall be carried out with compressed air or shot peening. If shot peening is used, it must be assumed that extra blast-cleaning with sharp-edged grit will be required to satisfy the roughness requirement. The compressed air shall be dry and free of oil. Greasy or oil-impregnated objects must be degreased/washed before they are blast-cleaned. Unless otherwise indicated by the supplier or in *the special specifications*, the following requirements apply:

- Cleanness: - Sa 3 according to NS-EN ISO 8501-1.
- The quantity of chloride shall be max. 20 mg/m² according to NS-EN ISO 8502-6.
- Roughness: 50-85 µm according to NS-EN ISO 8503-1 G segment 3.

The steel materials must be stored and blast-cleaned under such conditions that condensation does not occur. Cleaned surfaces must not be touched with bare fingers or exposed to rain, moist, salt-containing air, oil drips or other contaminants. After blasting, all loose remnants of the blasting abrasive must be blown or preferably vacuumed off the steel surface.

Blast-cleaned surfaces shall have the first layer of the selected corrosion-protection coating applied as soon as possible. At the least sign of visible rust formation on surfaces that have been cleaned to Sa3, re-blasting and repeat removal of loose particles is required.

e) Surface roughness shall be checked according to NS-EN ISO 8503-1. Cleanness with respect to dust shall be checked by means of the pressure-sensitive tape method according to NS-EN ISO 8502-3. Salt quantity shall be checked according to NS-EN ISO 8502-6.

x) As in Specification 85.3. Unit: m²

85.34 Metallizing

a) Comprises thermal spraying with zinc and hot-dip galvanising.

x) As in Specification 85.3. Unit: m²

85.341 Metallizing by thermal spraying with zinc

a) Comprises thermal spraying with zinc.

b-e) The steel components shall be thermally sprayed with zinc within 4 hours of blast cleaning.

All thermal spraying shall proceed in accordance with NS-EN ISO 2063, and the coating shall satisfy the requirements of this standard. Unless otherwise indicated in *the special specifications*, a minimum thickness of 100 µm is required. The metal layer shall be applied with the most even thickness possible. It can be required that a coating that is uneven (wavy) and with large thickness variations be removed, and a new layer applied. The same applies if measurements reveal several points with less than the specified thickness (100 µm).

Before further treatment takes place, the Project Owner shall be notified to give him the opportunity to perform independent checks of coating thickness and adhesion.

x) As in Specification 85.3. Unit: m²

85.342 Hot-dip galvanizing

- a) Comprises pre-treatment and metallizing based on hot-dip galvanizing (dipping in molten zinc). If there is to be overpainting, the specification also includes degreasing/washing and light blast-cleaning before painting.
- b-e) Hot-dip galvanizing is understood to mean coating with zinc by dipping of components in molten zinc. All pre-treatment with alkaline degreasing and pickling as well as hot-dip galvanizing shall proceed in accordance with NS-EN ISO 1461, and the coating shall satisfy the requirements in this standard.

The steel surface shall be pre-treated with an alkaline degreasing agent to remove grease and other contaminants and pickling to remove corrosion products and scale (oxide) due to heat treatment.

Choice of coating thickness

If the thickness of the hot-dip galvanized coating is to be larger than the minimum thicknesses described in NS-EN ISO 1461, this will be indicated in other parts of the general specifications which refer to this specification, or it will be indicated in *the special specifications*. It is a prerequisite that the choice of pre-treatment, steel materials and material thicknesses makes it possible to attain the specified zinc coating thickness.

The coating thickness is divided into the following classes, depending on the need for protection, thickness of the material and the composition and surface properties of the substrate:

Class A:

Intended for items for general use. The coating thickness in Table 85.342-1 corresponds to the minimum coating thickness in NS-EN ISO 1461 and can be achieved on most types of steel and cast iron.

Class B:

Intended for objects in a highly corrosive environment and/or when a long life is required. This class will apply to the majority of the Norwegian Public Roads Administration's structures along the roads, which are not to have a top coating as well. The coating thicknesses in Table 85.342-1 can be achieved on hot-rolled silicon-killed steels and on hot-rolled non-silicon steels if the surface has been blast-cleaned with steel balls.

Class C:

Intended for objects in a highly corrosive environment and/or when an extra long life is required. The coating thicknesses in Table 85.342-1 can be achieved on hot-rolled, silicon-killed steels if the silicon content is over 0.3%.

Note:

Before Class B or C is prescribed, an appropriate steel type must be specified. The party doing the hot-dip galvanizing should also be consulted. A shiny, pure zinc surface cannot be achieved for Classes B and C.

Table 8.5.342-1: Thickness of zinc coating from hot-dip galvanizing

Product (nominal thickness, t)	Class A		Class B		Class C	
	Min. thick- ness locally	Av. thickness on each object	Min. thick- ness locally	Av. thickness on each object	Min. thick- ness locally	Av. thickness on each object
mm	µm	µm	µm	µm	µm	µm
t > 6	See NS-EN ISO 1461, Table 2		100	115	190	215
3 < t ≤ 6			85	95	115	140
1.5 < t ≤ 3			60	70	Not applicable	
Small objects ¹⁾						
Casting material			Not applicable			

¹⁾ Small objects that are hot-dip galvanized in baskets and subsequently centrifuged to remove the surplus zinc.

During hot-dip galvanizing, internal stresses are released in the material with the result that harmful deformations can occur. Any cold repair shall take place in consultation with the Project Owner.

If the galvanizing is damaged, for example through the drilling of holes or cold cutting of galvanized steel components, the damage must be repaired immediately. The Project Owner shall decide whether Maintenance System 3 (Specification 88.48) or metallizing should be used. With autogenous cutting, the hardened zone must be ground off before treatment.

Hot-dip galvanized steel that is to be painted or powder coated shall not be handled, transported or temporarily stored out of doors or in damp surroundings. The least possible time shall pass between hot-dip galvanizing and further coatings to avoid white rust.

Burrs and lumps shall generally be removed after hot-dip galvanizing. Hot-dip galvanized surfaces that are to be painted shall be degreased/washed and blast cleaned very lightly with fine sand (0.2 – 0.5 mm) and loose particles removed. Hot-galvanized surfaces that are to be powder coated shall not be blast cleaned.

For hot-dip galvanizing of bolts, nuts and threaded fasteners, see Specifications 85.13 and NS-EN ISO 10684.

- x) As in Specification 85.3. Unit: m²

85.35 Application of paint/organic coatings

- a) Comprises all materials, work and equipment for applying paint/organic coatings, such as primer, base coat and top coat.

c) **Cleaning**

Metallizing or a paint coat that has become contaminated shall be degreased/washed and cleaned thoroughly before further painting. To be carried out as described in Specification 85.3.

Application

All paint products shall be stirred with a drill or similar in order to mix the pigments and liquid satisfactorily. After stirring it shall be ensured that any air that has been stirred in has time to escape.

The paint supplier's guidelines shall be followed with respect to mixing and thinning, application method and equipment.

Paint with heavy pigments, such as zinc, shall be stirred continually during application.

Paint shall normally be applied with a high pressure spray gun or with a paintbrush in the thickness and number of coats specified for the paint system in question. In some cases a "paint glove" shall be used (cables, bars in railings etc.). Compressed air shall be free of oil and water.

During painting work, it shall be ensured that no type of paint, with the exception of moisture-hardening paints, is exposed to moisture. Application shall only take place when the substrate is absolutely free of moisture and has been carefully cleaned of contaminants. For temperature and air humidity requirements, see "General requirements concerning execution" Specification 85.3 c). If necessary, the part that is to be painted must be enclosed and warmed up. The warming method shall be approved by the Project Owner.

Each coat must be applied continuously over the entire surface and shall be free of pinholes, pores, blisters and untreated patches. Dripping, sag, etc. shall be avoided. Any such defects shall be removed immediately and the surface re-coated.

Each coat shall dry and be over-painted according to the technical data sheet issued by the paint supplier.

Areas which because of the shape and size of the structure are difficult to reach with a spray gun, as well as bolt connections, ground edges and rounded corners, shall have a coat of paint applied with a brush (stripe coating) to ensure that the coating in these areas is of a satisfactory thickness. This local treatment shall be carried out before each paint coat that is to be sprayed on.

The dry film thickness of each coat shall be in accordance with the technical data sheet of the paint supplier unless otherwise indicated in *the special specifications*. The same applies to the total thickness of the paint system. Technical data sheets shall be available at the painting site at all times.

- x) As in Specification 85.3. Unit: m²

85.351 Sealer/tie-coat on thermally sprayed zinc

- a) Comprises sealer/tie-coat on metal coating to protect and pore-fill the metal surface.

- x) As in Specification 85.3. Unit: m²

85.352 Epoxy mastic

- a) Comprises painting/coating of steel structures with epoxy mastic.

- x) As in Specification 85.3. Unit: m²

85.353 Polyurethane/polyurethane acryl

- a) Comprises painting/coating with polyurethane or polyurethane acryl.

- x) As in Specification 85.3. Unit: m²

85.36 Powder coating

- a) Comprises pre-treatment and powder coating of hot-dip galvanized material. Hot-dip galvanizing is included in Specification 85.342.

- b) Test methods for pre-qualification of powder coating:

Table 85.36-1: Acceptance criteria for paint system in coating system 1	
Test	Acceptance criteria
ISO 20340	Acceptance criteria specified in ISO 20340 apply. Also applicable: <ul style="list-style-type: none"> • Adhesion over 5 MPa before test and less than 50% reduction after test (NS-EN ISO 4624) • Chalking: Rating 2 or less (NS-EN ISO 4628-6) • Over-paintable with top coat after testing without mechanical treatment of surface. Adhesion at least 5 MPa (NS-EN ISO 4624).

Polyester powder coating shall be used unless otherwise indicated in *the special specifications*. The colour code of the powder coating shall be indicated in *the special specifications*.

Hot-dip galvanizing and powder coating shall be carried out on the same premises without transportation or interim storage out of doors or in humid conditions.

The facility shall be ISO 9001 approved or have technical approval from SINTEF Building and Infrastructure for powder coating.

Coating system:

1. 90 µm metallic zinc applied by dipping in molten zinc (included in Specification 85.342).
2. Zinc phosphate or zinc manganese phosphate conversion layer.
3. Min. 75 µm polyester powder coating or similar product

Total coating thickness: Min. 165 µm

There shall be no white rust on surfaces that are to be powder coated.

The individual work operations in the application process shall be carried out within the time frame recommended by the coating supplier.

If any of the above requirements are contrary to the coating supplier's recommendations, the Project Owner shall be notified and if necessary the specifications adjusted according to agreement between the Project Owner and the supplier.

The specified dry film thickness shall not be less than that used in the qualification testing, and a minimum of 75 µm.

e) Before powder coating takes place, the hot-dip galvanizing layer shall be inspected for occurrences of white rust (zinc oxide and zinc hydroxide).

x) As in Specification 85.3. Unit: m²

85.37 Pre-treatment of steel bridge decks

a) Comprises pre-treatment of steel bridge decks as pre-treatment before waterproofing/surface courses which is covered by Specification 87.1

b-e) See Specifications 83.3, 85.33 and *the special specifications*.

Adhesion shall be checked by means of pull-off tests in accordance with NS-EN ISO 4624. 1 test consisting of 3 individual pull-offs shall be carried out for each 50 m² or part thereof. If the last 5 tests satisfy the requirement, the testing frequency can be reduced to 1 test per 500 m². Adhesion shall be at least 2 MPa. Inspection shall take place in accordance with Specification 85.3 and to the extent indicated in Table 85.3-2.

x) As in Specification 85.3. Unit: m²

85.4 Transport and erection of steel structures

a) Comprises transport of steel components from fabrication workshop to bridge site, unloading, storage at the fabrication workshop and at the bridge site and erection including all necessary adjustment to achieve the correct geometry according to *the special specifications*. The specification includes all costs for delivery of the finished steel structure that are not included in Specification 85.1-3.

c) Transport, storage and erection plans shall be prepared by the contractor (see *the special specifications*). The plan shall be submitted to the Project Owner for comment.

The structural members must not be subjected to damage during transport, storage, moving around or erection. This applies to both steel and corrosion protection.

Steel components that are stored shall be placed on wooden supports at least 20 cm above the ground. If a number of layers are stacked on top of one another, planks shall be placed in between them.

The components must be stacked in a manner that allows water to run off and air to circulate freely to all surfaces. This is particularly important with galvanized surfaces to avoid white rust.

If the stored steel components are exposed to sea spray or contaminants of any type they shall be protected with a complete cover. It must be ensured that there is good air circulation under the cover.

The contractor shall prepare calculations and drawings for lifting lugs, attachments for transport securing etc. The design shall allow for additional dynamic loads that may occur. All documents shall be sent to the Project Owner for comment.

e) All lifting lugs and attachments for securing during transport shall be inspected according to Inspection Class 3. The inspection documentation shall be handed over to the Project Owner before transportation can take place.

x) As in Specification 85.1. Unit: ton

85.41 Transport of steel structures

- a) Comprises transport from the fabrication workshop to the bridge site and unloading. Also includes any storage at the bridge site.
- c) Components that are transported by boat and stacked on deck shall be covered and fully protected against sea spray. If this is not possible, all steel shall be thoroughly cleaned by high-pressure hosing (100-150 bar) with clean water on arrival at the construction site, so that the salt water level of cleaned surfaces does not exceed 100 mg/m².

If overland transport takes place, the contractor must himself investigate accessibility for vehicles and procure any dispensations required in this connection.

Hooks for lifting steel components shall have rubber-covered sides or similar protection to reduce damage to the surface to a minimum. No wire or chain straps shall be in direct contact with the steel components.

In the case of transport by sea, the contractor shall prepare calculations of the sea transport according to DNV's or equivalent rules and regulations.

Unless otherwise agreed, all transport shall be for contractor's responsibility and risk.

- x) As in Specification 85.1. Unit: ton

85.42 Erection of steel structures

- a) Comprises internal transport at the bridge site and erection of steel structures.

Also comprises preparation of an assembly plan, execution of necessary measuring work and any cleaning of contaminated components.

- c) In the case of high structures, the contractor shall arrange for warnings and the setting up of warning lights in accordance with currently applicable rules.

For structures spanning shipping channels, the contractor shall obtain the necessary authorisations from the Norwegian Coastal Administration/port authorities and arrange for the prescribed marking and warnings.

Erection shall be directed by qualified persons with both a practical and a theoretical knowledge of steel structures.

Before erection begins, the contractor shall prepare an erection plan that must be submitted to the Project Owner for comment. The erection plan shall contain the following:

- Description of the operations necessary for carrying out the erection, and their order.
- Drawings and description of mechanical equipment, scaffolding and bracing that are to be used in the various operations, and a description of how they are intended to be used.
- Statical calculations that show clearly which forces the steel parts are subjected to during the various operations, and that these operations can be carried out without risk to the stability and safety of the structure. The calculations shall take account of any wind load, in accordance with NS 3491-4. A return period of 10 years can be used in the calculations.

Components that are damaged (bent, etc.) during transport or in any other manner, may not be assembled before satisfactory repair has been carried out according to agreement with the Project Owner.

Parts that are contaminated by sand, dirt, oil, salt etc. must be cleaned before erection. If the components have been in direct contact with salt or saltwater, for example sea spray, they shall be washed thoroughly with clean freshwater by means of high-pressure hosing (100-150 bar). In the case of more extensive contamination, cleaning will be considered for the individual case.

The bridge components shall be assembled in the exactly correct shape, with the camber measured at the fabrication workshop, etc.

Final broaching of holes in structures that have not been trial assembled at the fabrication workshop or the insertion of bolts in finished holes must not take place before the shape and fit of the structure (aligned holes) has been verified.

The same requirements apply to site welding as to welding at the fabrication workshop (see Specification 85.24). Assembly work shall be planned and executed such that steel components and corrosion protection are not damaged. At site welds, adjacent corrosion-protected surfaces shall be thoroughly protected against splashing from tooling, machining and welding.

Bearings shall be installed according to the supplier's directions, unless otherwise indicated in *the special specifications*. The transfer of the weight of the steel to the bearings must be carried out carefully.

The contractor shall finance and arrange for the necessary bracing and guying for anchoring and securing of the steel structure during the construction period. He shall ensure that guys, braces, auxiliary cables etc. do not damage the structure.

Lifting lugs, attachments for securing during transport and all other support steel shall be removed after use unless otherwise agreed with the Project Owner. Adjacent surfaces shall be covered well before the work starts. The steel components shall be burnt off at a distance of at least 5 mm from the load-bearing structure, and the remaining material ground away down to the substrate. Grinding shall take place in the rolling direction. Damage to the corrosion protection shall be repaired as described in Specification 85.3.

All necessary measurements shall be taken by the contractor. The necessary basis for these measurements, for example bridge axis, pile no., and a basic height reference reasonably close to abutments or piers, shall be indicated by the Project Owner. Erection shall proceed at contractor's responsibility and risk, irrespective of inspections made by the Project Owner.

- x) As in Specification 85.1. Unit: ton

85.421 Rigging for erection of steel structures

- a) Comprises all measures necessary to put cranes, assembly equipment and other accessories into an operational condition at the site, for example temporary supports/foundations/anchors/pad-eyes for guys, means of access (that are not covered by Principal Specification 1), mobile rigging, assembly scaffolding etc., and removal of rigging and temporary installations after use.
- c) The work shall be carried out in a satisfactory manner in accordance with currently applicable Norwegian Standards for the materials that are used and the Norwegian Labour Inspection Authority's rules.

For conditions on the site, see *the special specifications*.

- x) Costs shall be given as a lump sum. Unit: LS

85.422 Erection work

- a) Comprises transport on the erection site, erection and adjustment and all work that is necessary to deliver the structure(s) in accordance with the plans and *the special specifications*.

- x) As in Specification 85.1. Unit: ton

85.43 Surface treatment after erection

- a) Comprises delivery and application of complete corrosion protection to site assembly joints and any remaining coats of paint that were not applied at the fabrication workshop. The specification also includes pre-treatment prior to surfacing work on steel decks (see Specification 85.37). Repair of damage to the coating is included in Specification 85.3.

b-c) General requirements

Surface treatment after erection, together with surface treatment at the fabrication workshop, shall comprise complete surface treatment (see Specification 85.3 and *the special specifications*).

Requirements regarding materials and execution are given in Specification 85.3.

Welded splices

The area around the site welds shall be cleaned. The welds and areas that were not metallized before site assembly (see Specification 85.3 c), shall be blast cleaned. It is important that areas that are not to be blast cleaned be properly masked to prevent damage to the coating due to splashing. Complete corrosion protection shall be applied to the splice area in the same way as to the rest of the bridge.

Bolted splices

After tightening, the bolts shall be thoroughly cleaned of all lubricant. All bolt heads, nuts, washers and bolt ends shall be fully painted in the same way as the rest of the bridge.

- x) As in Specification 85.3. Unit: m²

85.431 Rigging for surface treatment and inspection

- a-c) As in Specifications 88.41, 88.411 and 88.412.

- x) Costs shall be given as a lump sum. Unit: LS

85.432 Thermally sprayed zinc after erection

- a) Comprises thermally sprayed zinc after erection.

- b-x) As in 85.341. Unit: m²

85.433 Sealer/tie-coat on metal coating after erection

- a) Comprises application of sealer/tie-coat after erection.

- b-x) As in 85.351. Unit: m²

85.434 Epoxy mastic after erection

- a) Comprises application of epoxy mastic after erection.

- b-x) As in Specification 85.352. Unit: m²

- 85.435 Polyurethane paint after erection**
- a) Comprises application of polyurethane or polyurethane acryl after erection.
 - b-x) As in Specification 85.353. Unit: m²
- 85.436 Pre-treatment of steel bridge decks after erection**
- a) Comprises pre-treatment of steel decks after erection and before the surfacing work in Specification 87.1.
 - b-e) See Specification 85.37 and *the special specifications*.
 - x) As in Specification 85.3. Unit: m²
- 85.5 Delivery and assembly of steel structural elements**
- a) Comprises delivery and assembly of steel elements.
Elements forming part of a delivery for a steel structure are included in Specifications 85.1-85.4 Joints, bearings, water outlets, parapets, lighting masts and booms of steel are included in Specification 87. Cables for suspension bridges and stay cable bridges are included in Specifications 85.6 and 85.7.
 - b) See Specification 85.1 unless otherwise indicated in *the special specifications*.
 - c) See Specifications 85.2-4 unless otherwise indicated in *the special specifications*.
 - e) Steel load-bearing structural elements shall be fabricated according to Inspection Class 2 unless otherwise indicated in *the special specifications*.
 - x) Quantity shall be measured as net planned weights according to final bills of materials. The density of steel is assumed to be 7.85 kg/dm³. Additions shall not be made for welding, and deductions shall not be made for bolt holes and weld joint preparations. Unit: ton
- 85.52 Delivery and installation of gratings**
- a) Comprises delivery and installation of gratings with fasteners.
 - c) Gratings shall be delivered hot-dip galvanized in accordance with Specification 85.342.
Gratings shall be delivered and installed with fasteners so that they remain firmly in place without horizontal displacement.
 - x) Quantity shall be measured as planned grating area. Unit: m²
- 85.521 Delivery of vehicle-proof gratings (heavy duty gratings that withstand the weight of vehicles)**
- a) Comprises delivery of vehicle-proof gratings with fasteners incl. accessories for assembly, to a designated place on the construction site.
 - x) Quantity shall be measured as planned grating area. Unit: m²
- 85.522 Installation of vehicle-proof gratings**
- a) Comprises installation of vehicle-proof gratings.
 - x) Quantity shall be measured as planned grating area. Unit: m²
- 85.523 Delivery of non-vehicle-proof gratings**
- a) Comprises delivery of non-vehicle-proof gratings with fasteners incl. accessories for assembly, to a designated place on the construction site.
 - x) Quantity shall be measured as planned grating area. Unit: m²
- 85.524 Installation of non-vehicle-proof gratings**
- a) Comprises installation of non-vehicle-proof gratings.
 - x) Quantity shall be measured as planned grating area. Unit: m²
- 85.53 Delivery and assembly of saddles and anchorages for cables**
- a) Comprises delivery and installation of saddles and anchorages for load-bearing cables and hangers as indicated in *the special specifications*. Installation includes cleaning of recesses/construction joints and any fitting and concreting of saddle plates.
 - c) The elements shall be fabricated in accordance with Inspection Class 3.
 - x) Quantity shall be measured as net planned weights according to bills of materials. Unit: ton
- 85.531 Delivery of saddles and anchors for cables**
- a) Comprises delivery of all components for saddles and anchorages to a prescribed place on the building site.

- b-c) See *the special specifications*.
- x) Quantity shall be measured as net planned weight according to bills of materials. Unit: ton
- 85.532 Installation of saddles and anchorages for cables**
- a) Comprises all work and accessories for complete installation of saddles and anchorages. Any concreting is included in Specification 84.
- b-c) See *the special specifications*.
- x) Quantity shall be measured as net planned weight according to bills of materials. Unit: ton
- 85.54 Culverts of steel pipe, light opening L > 2.5 m**
- Comprises all costs associated with delivery and installation of corrugated steel pipe with light opening L > 2.5 m, including delivery and production of necessary accessories described in the installation instructions.
- The work of excavation, preparation/compaction of the ground and backfilling forms part of Specification 81. Specification 84 shall be used for any concreting of the bottom of the pipe and/or cast-in-situ inlet or outlet structures.
- For corrugated steel pipe with a light opening of < 2.5 m, see Specification 45.
- The steel pipes shall be delivered with shape, dimensions and corrosion protection as indicated in *the special specifications*.
- Installation shall take place as described in the plans and *the special specifications*. See also the supplier's instructions and assembly directions.
- x) Quantity shall be measured as length of manufactured steel pipe of each type and size. Unit: m
- 85.541 Delivery of corrugated steel pipe**
- a) Covers all costs of delivering undamaged corrugated steel pipe including installation bolts and any other accessories to the designated place at the construction site.
- x) Quantity shall be measured as length of fabricated steel pipe of each type and size. Unit: m
- 85.542 Delivery of inlet/outlet structure of corrugated steel pipe components**
- a) Comprises all costs associated with delivery of undamaged corrugated steel pipe components for inlet/outlet structure, as prescribed in the plans and *the special specifications*, including assembly bolts and any other accessories, to the designated place at the construction site.
- x) Costs shall be given as a lump sum. Unit: LS
- 85.543 Special surface treatment of corrugated steel pipe**
- a) Comprises surface treatment of corrugated steel pipe as described in *the special specifications*.
- x) Quantity shall be measured as planned surface treatment area, measured in the plane defined by the neutral axis of the steel plates. Unit: m²
- 85.544 Installation of corrugated steel pipe**
- a) Comprises complete installation of corrugated steel pipe as prescribed in the plans and *the special specifications*.
- x) Quantity shall be measured as completed length of steel pipe of each type and dimension. Unit: m
- 85.545 Installation of inlet/outlet structure of corrugated steel pipe components**
- a) Comprises complete installation of corrugated steel pipes as prescribed in the plans and *the special specifications*.
- x) Costs shall be given as a lump sum. Unit: LS
- 85.6 Delivery of bridge cables**
- a) Comprises delivery of cables with sockets for suspension bridges and cable-stayed bridges to prescribed storage place.
- b-e) See Handbook 122, Cables for suspension bridges and cable-stayed bridges, and *the special specifications*.
- x) Quantity shall be measured as net delivered weight of cables with sockets. Unit: ton
- 85.7 Transport and installation of cables**
- a) Comprises transport from storage place to bridge site, installation, adjustment and surface treatment of cables with sockets for suspension bridges and cable-stayed bridges, and extra surface treatment of cable anchorages after installation.
- b-e) See Handbook 122 and *the special specifications*.

- x) Quantity shall be measured as net installed weight of cables with sockets. Unit: ton
- 85.71 Transport of cables**
- a) Comprises all work and materials associated with loading, handling and transport of cables from the storage place right to the bridge site.
Comprises further work and materials associated with unloading and support at the bridge site.
 - b) All materials shall be of such dimensions and quality that cables and sockets are protected during transport and handling.
 - c) The transport and handling of the cables in connection with unloading must proceed in such a manner that the cables and drums cannot be damaged. It is important to take care with loading on quays, roads, bridges etc. It must also be ensured that cables cannot move or roll during transport and storage.
In the case of overland transport, the contractor must himself investigate vehicle accessibility and procure any dispensations required in this connection.
- x) Quantity shall be measured as net weight of cables and sockets. Unit: ton
- 85.72 Rigging for installation of cables**
- a) Comprises rigging and derigging of whim capstan, auxiliary cables, catwalks etc. that are necessary for accurate installation and adjustment of cables in accordance with the plans.
 - c) The work shall be carried out in a satisfactory manner in accordance with currently applicable Norwegian Standards for the materials that are used, and to the Norwegian Labour Inspection Authority's rules.
- x) Costs shall be given as a lump sum. Unit: LS
- 85.73 Cable installation**
- a) Comprises all necessary work for accurate installation of cables according to the plans.
- x) Costs shall be given as a lump sum. Unit: LS
- 85.74 Cable adjustment**
- a) Comprises all necessary work for precise adjustment of cables according to the plans.
- x) Costs shall be given as a lump sum. Unit: LS
- 85.75 Surface treatment of cables**
- a) Comprises cleaning and surface treatment of cables and cable anchorages after installation. The specification includes removal of surplus spinning compound from the cable surface.
 - b-c) See Specifications 85.3, 85.33 and *the special specifications*. Surplus spinning compound which forms clumps or cakes shall be removed in connection with cleaning.
 - e) See Specification 85.3, Inspection Class 2 and *the special specifications*.
- x) Costs shall be given as a lump sum. Unit: LS
- 85.751 Rigging for surface treatment of cables**
- a-c) As in Specification 85.431.
- x) Costs shall be given as a lump sum. Unit: LS
- 85.752 Painting work on cables**
- a) Comprises delivery and application of paint in accordance with *the special specifications*.
- x) Costs shall be given as a lump sum. Unit: LS
- 85.753 Surface treatment of sockets, saddles, cable clamps and anchorages**
- a) Comprises surface treatment of sockets, saddles, cable clamps and anchorages for cables and hangers in accordance with *the special specifications*.
- x) Costs shall be given as a lump sum. Unit: LS
- 85.754 Filler at sockets**
- a) Comprises joint filler between cable and socket according to *the special specifications*.
- x) Costs shall be given as a lump sum. Unit: LS

86 WOOD, STONE, ALUMINIUM ETC.

86.1 Wood

- a) Comprises all materials and work in connection with delivery, working, transport, storage and assembly of structures made of wood.

Comprises all necessary production drawings in addition to those supplied by the Project Owner in the tender documents.

Comprises delivery and assembly of connectors, fittings, bolts, wood screws, nuts, washers, slotted plates, dowels, etc., as well as pre-stressing bars with accessories.

Does not include structural parts made of steel that form part of the timber structure. See Specification 85 and *the special specifications*.

Joint structures, bearings, parapets (also parapets with wooden rails) and other equipment are included in Specification 87. Bearing stringers of wood are included in Specification 86.1

- b-c) All materials and all execution shall be in accordance with Norwegian Standards, and the standards referred to in these provided no variations are specified in the following specifications or in *the special specifications*.

Work on the delivery shall be carried out in close contact and cooperation with the Project Owner. The contractor undertakes to keep the Project Owner informed about the progress of the work and shall notify him of any problems during the work that could affect the product's quality or the delivery time.

86.11 Delivery of materials for timber structures

- a) Comprises delivery of materials for timber structures in accordance with *the special specifications*.
- c) The contractor shall check that the materials are delivered with the right dimensions and qualities at the right time. The materials shall be labelled, handled and stored so that they are not damaged and so that the labelling is easily visible.

86.111 Delivery of structural timber

- a) Comprises delivery of structural timber in accordance with *the special specifications*.
- b) Structural timber shall have documented strength grades in accordance with NS-EN 338. All structural timber is required as a minimum to conform to strength grade class C18.
- Finger jointed timber shall be manufactured in accordance with NS-EN 385. The product shall be CE marked. Alternatively, while waiting for a system of CE marking to come into force, manufacture shall be subject to the Norwegian Glulam Control (NLK) or a similarly recognised inspection authority, and be marked in accordance with the inspection authority's rules.
- If finger jointed timber cannot be used, this shall be stated in *the special specifications*. Impregnated materials shall satisfy all the requirements in Specification 86.131.
- d) Tolerance requirements for structural timber are specified in NS-EN 336. See also *the special specifications*.
- x) Quantity shall be measured as planned volume. Unit: m³

86.112 Delivery of glued laminated timber

- a) Comprises delivery of glued laminated timber, including lamellae of glued laminated timber for stress-laminated decks.
- b) glued laminated timber shall be manufactured in accordance with NS-EN 386 and have strength and stiffness properties documented either by calculations according to NS-EN 1194 or by testing according to NS-EN 408. The product shall be CE marked. Alternatively, while waiting for a system of CE marking to come into force, the manufacturing shall be subject to the Norwegian Glulam Control (NLK) or a similarly recognised inspection authority, and be marked in accordance with the inspection authority's rules.
- The lamellae shall be glued with waterproof, weatherproof glue. For block gluing of glued laminated timber, i.e. when two or more glued laminated timber components are glued together, waterproof, joint-filling glue shall be used.
- For impregnated glued laminated timber, lamellae of Nordic pine shall be used and efforts made to have little or no heartwood on the outside.
- d) Dimension tolerance requirements for glulam are specified in NS-EN 390. Maximum deviation in form is L/500. See also *the special specifications*.
- x) Quantity shall be measured as planned volume. Unit: m³

86.113 Delivery of connectors and stays

- a) Comprises delivery of screws, bolts, threadbars, stays, dowels, slotted plates and fittings for use in timber structures. For large hinge structures etc. of steel, see Specification 85 even if they have slotted plates.
- b-c) Steel connectors shall have strength and other material properties in accordance with Specifications 85, 85.1, 85.13 and any other relevant subspecifications. Wood screws shall be of at least steel type 4.6.

Threadbars shall be at least steel type 8.8. Rod dowels shall be of acid proof steel NS-EN 10088 1.4404, 1.4418, 1.4435, 1.4436 or equivalent. Washers shall be as described in NS 3470-1.

Slotted plates shall have rounded corners and no sharp edges.

Surface treatment shall be hot-dip galvanizing in accordance with Specification 85.342 with a coat thickness corresponding to Class B. Screws and nuts shall be hot-dip galvanized according to NS-EN ISO 10684. Slotted plates shall be hot-dip galvanized and powder-coated in accordance with Specification 85.342 and 85.36. See also *the special specifications*.
- d) Rod dowels shall have ISO h9 dimensional tolerance. Holes for rod dowels in slotted plates shall not have a diameter larger than the rod dowel diameter + 1.0 mm.
- x) Quantity shall be measured as net planned weight according to final bills of materials. Unit: ton

86.12 Working of structures and structural components of wood

- a) Comprises working of wood carried out in factories as indicated in *the special specifications*.
- c) The work shall be carried out by persons who have the necessary qualifications and experience. See the individual specifications and *the special specifications*. For structural components that are to be impregnated with creosote, all working shall be done prior to impregnation.

Cutting timber for stress-laminated decks shall be done according to precise plans so that the best possible distribution of joints over the bridge deck is achieved. The plan for laying the deck shall be submitted to the Project Owner/consultant before production.
- d) The width of slots in slotted plates shall normally not be more than 2 mm larger than the plate thickness. Holes for rod dowels in wood shall not have a larger diameter than that of the rod dowel (cf. Specification 86.113).
- x) Quantity shall be measured as planned volume. Unit: m³

86.121 Working of structural timber

- a) Comprises working of structural timber and finger jointed timber.

86.122 Working of glued laminated timber

- a) Comprises working of glued laminated timber.

86.13 Preservation of timber structures

- a) Comprises chemical and structural preservation and surface treatment of timber structures.
- c) The work shall be carried out such that the structure is protected against rot development, infestations of insects and micro-organisms. The work shall be carried out by persons who have the necessary qualifications and experience.

86.131 Pressure treatment of timber

- a) Comprises pressure treatment of Nordic pine.
- c) Treatment shall take place in accordance with Nordic wood preservation, defined by the Nordic Wood Preservation Council (NWPC) in NWPC Document No. 1:1998 "Nordic wood preservation classes", as indicated in the subspecifications or as indicated in *the special specifications* according to NWPC Document No. 3:1998 "Nordic requirements for quality control and marking of pressure treated timber".
- x) Quantity shall be given as planned volume to be treated. Unit: m³

86.1311 Pressure treatment of structural timber with creosote

- a) Comprises creosote treatment of structural timber, including lamellae of structural timber for stress-laminated decks.
- c) Treatment shall be carried out to at least Nordic wood preservation class AB or as indicated in *the special specifications*. Pressure treatment shall be carried out after all working is completed. Slotted steel plates and other steel fixings shall not be mounted before pressure treatment takes place.

When delivered at the construction site, materials that have been treated with creosote shall be drip-free and each individual component shall have a predominantly dry surface. Any creosote spillage on structures or other parts of the site shall be removed before the Project Owner takes possession.

86.1312 Pressure treatment of glulam with creosote

- a) Comprises creosote treatment of glued laminated timber, including glued laminated timber lamellae for stress-laminated decks.

- c) Penetration of the preservative agent:

There shall be close to full sapwood penetration.

In the case of block gluing, there shall be close to full penetration in the part of the sapwood that is exposed on the outer surfaces and is not confined by heartwood and or glue joints.

Absorption of preservative agent:

Laminated lamellae for stress-laminated decks and other protected parts: 80-90 kg/m³ treated sapwood.

Edge beams of glued laminated timber and glued laminated timber with unprotected sides: minimum 100-110 kg/m³ treated sapwood.

In the case of block gluing, absorption applies only to sapwood that is exposed on the outer surface.

Pressure treatment shall be carried out after all working is completed. Slotted steel plates and other steel fixings shall not be mounted before pressure treatment takes place.

When delivered, materials that have been treated with creosote shall be drip-free and have a predominantly dry surface. Any creosote spillage on structures or other parts of the site shall be removed before the Project Owner takes possession.

- e) Inspection of absorption shall be carried out according to Nordic Wood Preservation Council (NWPC) Document No. 3:1998.

86.1313 Pressure treatment of structural timber with Cu salt

- a) Comprises treatment with salt preservatives of structural timber for timber structures.
- c) Treatment shall be carried out to Nordic wood preservation class A or as indicated in *the special specifications*.

86.1314 Pressure treatment of structural timber with other preservation agents

- a) Comprises pressure treatment of structural timber for timber structures using alternative preservation agents and/or specifications (oil treatment, non-metallic preservation agents, etc.) as indicated in *the special specifications*.
- c) Treatment shall be carried out to Nordic wood preservation class AB or as indicated in *the special specifications*.

86.1315 Pressure treatment of lamellae for glued laminated timber

- a) Comprises a supplement for delivery of glued laminated timber with pressure-treated lamellae.
- c) The lamellae shall be made of timber that is pressure-treated with Cu salt preservatives to Nordic wood preservation class A or with other agents as indicated in *the special specifications*.

86.1316 Pressure treatment of glued laminated timber with other preservative agents

- a) Comprises pressure treatment of finished glued laminated timber, including glued laminated timber lamellae for stress-laminated decks, with alternative preservative agents as indicated in *the special specifications*.
- c) There shall be close to full sapwood penetration. In the case of block gluing, there shall be close to full penetration of the part of the sapwood that is exposed on the surface and not confined by heartwood or glue joints.

Absorption of preservative agent as indicated in *the special specifications*. In the case of block gluing, absorption applies only to sapwood that is exposed on the outer surface.

86.132 Surface treatment using paint and stains

- a) Comprises surface treatment of timber structures using paint and stains.
- b) Only oil-based paint or stain types shall be used. See also *the special specifications*.
- c) The paint or stain shall be applied in the amount, specified in g/m², and number of coats indicated in *the special specifications*.
- x) Quantity shall be measured as planned area to be surface treated. Unit: m²

86.133 Other chemical wood preservation

- a) Comprises other chemical wood preservation such as treatment using boron, placement of boron rods in drillholes, etc. as indicated in *the special specifications*. The specification may also include post-treatment of timber that has begun to rot.
- b-x) As indicated in *the special specifications*.

86.134 Structural preservation

- a) Comprises structural preservation measures to ensure the life necessary for timber structures as indicated in *the special specifications*.

86.1341 Plate metal cladding

- a) Comprises cladding with thin copper, zinc or stainless steel plates for protection against the effects of rain and sun.
- b) Cladding shall be made of plate metal with a minimum thickness of 0.7 mm or as specified in *the special specifications*. The use of plastic-coated steel plates or similar is unacceptable.
- c) Copper cladding does not have to be installed with an air gap between the plate and the wood. The joining of individual fixing parts shall be carried out as standing-seam metal panels with concealed fasteners. The cladding shall protrude beyond the individual wooden component and end in a drip mould.

The runoff water from copper cladding must not be drained onto zinc or galvanized components. Nor must copper come into contact with zinc where water can ingress.

- x) Quantity shall be measured as planned area to be covered. Unit: m²

86.1342 Wooden louvres

- a) Comprises cover on the sides of glulam arches or other structures with wooden louvres consisting of wooden slats and steel fastening brackets in accordance with *the special specifications*.

- x) Quantity shall be measured as planned area to be covered. Unit: m²

86.13421 Wooden slats

- a) Comprises delivery and assembly of wooden slats complete with material to fasten these to brackets.
- b) Structural pine timber with dimensions of 15 × 73 mm in declining lengths in accordance with *the special specifications*.
- c) The slats shall be forced into their final form on site as they are fastened to the brackets. Fastening slats to the brackets is done with self-drilling, stainless steel, hexagonal socket head screws. When joining, the slats are cut on site, set butt to butt over a fastening bracket and fastened with one screw and a square clamping plate of lacquered steel (cf. fastening brackets in Specification 86.13422).

- x) Quantity shall be measured as planned volume. Unit: m³

86.13422 Fastening brackets for wooden slats

- a) Applies to fastening brackets of bent flat rolled steel for fastening louvres on arch sides or other structures as indicated in *the special specifications*.

The specification also includes assembly, complete with M8 bolts and washers for fastening to laminated timber arches or other structures as indicated in *the special specifications*.

- b-c) Flat rolled steel dimensions 3 × 60 mm (if relevant t=2 mm). Steel grade S235. The steel shall be hot-dip galvanized and powder-coated in accordance with Specification 85.342 and 85.36 in the colour black-brown - RAL 8022 - unless otherwise indicated in *the special specifications*.

The fastening brackets shall be cut on the lower edge if the cross-sectional height declines towards the end of the arch. Cutting may be done on site if the cut surface is repaired in accordance with Specification 85.43.

- x) Unit: ton

86.13423 Pressure treatment of wooden slats with creosote

- a) Comprises creosote treatment of wooden slats for louvres as specified in Specification 86.1311 or in *the special specifications*.

- x) Quantity shall be given as planned volume to be impregnated. Unit: m³

86.14 Transport, storage and assembly of timber structures

- a) Comprises all necessary transport and storage of all materials and structural elements and assembly of the structure.

- c) Materials and bridge elements must not be subjected to damage during transport, storage or assembly. Materials and structural elements that have undergone major damage or deformation during transport or storage shall not be used.

See also the individual specifications and *the special specifications*.

86.141 Transport and storage of timber structures

- a) Comprises transport and storage of all materials and structural elements.

- c) The contractor shall see that permits from the road authorities are obtained where these are necessary. Unless otherwise agreed, all transport shall be for contractor's responsibility and expense. See also *the special specifications*.

During storage, the form stability of structural elements must be safeguarded with the necessary use of points of support. Necessary cover shall be provided so that material and structural components do not deteriorate.

- x) Quantity shall be measured as planned volume. Unit: m³

86.142 Assembly of timber structures

- a) Comprises assembly and adjustment of structures made of wood. Also includes installation of all necessary steel parts for joining wood components, such as slotted plates and dowels, etc.
- c) The work shall be carried out by persons having the necessary qualifications and experience.

Disposal of creosote- or salt-treated wood waste shall take place according to current regulations. See Handbook 211 Avfallshåndtering [Waste management], the individual specifications and *the special specifications*.

- d) Tolerance requirements for the finished structure are given in NS 3420 and *the special specifications*.
- x) Costs shall be given as a lump sum. Unit: LS

86.143 Erection of arches

- a) Comprises erection of glulam arches with abutment hinges that are fastened to the abutment with grouted/embedded threaded bolts. Erection includes cleaning of recesses and cast joints and adjustment and securing of bearings.

Grouting of bolts and bearing plates shall be carried out according to Specification 84.87.

Measures shall be taken to ensure that air is not trapped during grouting resulting in the formation of cavities.

The abutment bearings shall not be grouted until the arches are erected and inspected so that any necessary adjustments can be carried out. Hinge pins are fastened with locking screws or similar to prevent slippage unless otherwise indicated in *the special specifications*.

- d) Measuring-in abutment bearings shall be done with extreme precision. The contractor shall adapt the structural tolerances of the load-bearing components so that the maximum deviation in the top element, or top point for the arches without a top element, is not larger than ± 40 mm vertically and ± 20 mm horizontally.

Arches shall not have a geometric deviation so large that the tolerance requirements for stress-laminated decks in Specification 86.144 cannot be satisfied.

The above-mentioned deviation applies in relation to the intended geometry, defined as the structure's form under full self-weight. See also *the special specifications*.

- x) Costs shall be given as a lump sum. Unit: LS

86.144 Assembly of stress-laminated deck

- a) Comprises assembling lamellae into a stress-laminated deck. Does not include drilling of holes for tension rods or other working before assembly. This is included in Specification 86.12.
- c) Butt joints are made with an air gap of maximum 10 mm.

For vertical curvature where lamellae are not pre-curved, edges that protrude more than 10 mm in relation to the surroundings shall be planed down.

Cutting and adjustment of creosote-treated lamellae after treatment must be avoided. This especially applies to end wood. If this nonetheless must be done, it shall take place according to agreement with the Project Owner. Preservative fluid shall be applied to cut surfaces.

If weather conditions are such that laying the membrane must be delayed for a longer period (e.g. until after winter), the deck shall be protected before any temporary traffic is permitted. This can also be done by laying fibre membrane and a layer of gravel, with a temporary surface course of wood or in some other way according to agreement with the Project Owner.

- d) The finished pre-stressed deck shall be even. The following tolerances apply before membrane is laid:

- 1) Combined building tolerance ± 30 mm
- 2) Surface deviations: depressions and bulges, lamellae that protrude or are depressed, etc.

measured length 1 m: ± 5 mm
measured length 3 m: ± 8 mm

Max. deviation from the correct level difference measured within 20 m: ± 15 mm

- x) Quantity shall be measured as planned area. Unit: m²

86.1441 Tension work for stress-laminated decks

- a) Comprises delivery of single bar tendons including anchor plates, nuts and permanent corrosion protection of all components, assembly and tensioning. Also includes post-inspection to see that the intended tension force is achieved in all rods immediately after tensioning and inspection after about one year or at a time indicated in *the special specifications*.

Also includes cutting of rods to the correct length after tensioning and treatment of the cut surface with a zinc-rich primer.

Drilling holes in the lamellae for the rods is included in Specification 86.12.

- b) Pre-stressing system

The pre-stressing system shall be a recognised bar assembly and in conformance with European Technical Approval (cf. NS 3465).

Pre-stressing steel with a minimum characteristic proof stress of $R_{0.2}=900 \text{ N/mm}^2$ and minimum $R_m/R_{0.2}=1.10$ shall be used. Pre-stressing bars and nuts shall be sandblasted to $S_a 2.5$ (NS-EN ISO 8501-1) and spray galvanized to a coat thickness of minimum $100 \mu\text{m}$ in accordance with Specification 85.341.

All components of a tension unit shall be compatible, for example be from the same pre-stressing system and be rated for the tension force concerned. Bars, nuts and associated corrosion protection shall not be damaged or flawed.

A description of the tension system shall be sent to the Project Owner on request. In addition to specification of manufacture, type and supplier, the description shall contain information about:

- Type of steel ($R_m/R_{0.2}$)
- Stress/strain diagram
- Relaxation (for 10 000 hours)
- The bar's modulus of elasticity and cross-section (mm^2).
- Anchor lock loss (slip) (mm)
- Drawings and description of the pre-stressing system's individual components

Anchor plates

The anchor plates will not normally be part of the pre-stressing system, but purpose-manufactured. They shall be circular or have a rounded shape and a minimum thickness of 20 mm unless otherwise indicated in *the special specifications*. The edges shall be rounded for reasons of surface treatment (cf. NS 3464). Steel type shall be NS-EN 10025-2 – S235J0 or better. The plates shall be hot-dip galvanized in accordance with Specification 85.342 with a coat thickness corresponding to Class B. Alternatively they can be hot-dip galvanized and powder-coated in accordance with Specifications 85.342 and 85.36 with colour as indicated in *the special specifications*.

The weight of the anchor plates is indicated in *the special specifications*.

Documentation

Engineering data, identification documents and approval documents for all materials used in the pre-stressing system shall be available at the construction site.

When materials are delivered to the building site, they shall be accompanied by a delivery note. Materials without satisfactory documentation shall be refused.

Delivery notes, test reports and any possible deviations shall be recorded in the tensioning protocol.

- c) Transport and storage

All pre-stressing steel with accessories, anchor plates and nuts shall be transported, handled and stored in a way that is not detrimental to the finished product. The storage place on the building site shall be located in a minimally corrosive environment. Tension bars shall be stored in a dry, level place and be elevated on wood supports, at least 0.1 m above the ground. Accessories shall be stored in an airy, dry place so that they are not damaged or soiled and so that rust does not develop on the internal threads of the nuts. Surface water shall be drained away from the storage place. All components shall be cleaned in as far as is necessary before being used.

Tensioning

Tensioning shall be supervised and carried out by professionals with the necessary knowledge of the pre-stressing system and experience from such work. Competencies shall be documented for the Project Owner. The contractor shall notify the Project Owner before tensioning starts.

Valid calibration documents for tensioning equipment shall be submitted to the Project Owner well before tensioning starts.

Prior to the start of work, a written procedure for the tensioning shall be prepared. It shall contain a description of the equipment to be used, the tensioning sequence, how it is to be ensured that all tendons are given the intended force and how this is to be verified. The procedure shall be submitted to the Project Owner well before tensioning starts.

Tension forces shall be checked by manometer or dynamometer readings. During tensioning, records shall be kept that as a minimum show the date the tensioning was carried out and the tension forces

read off during measuring checks. When using a manometer, the protocol shall also contain the jack's piston area and internal friction. After tensioning, the Project Owner shall receive a copy of the protocol.

During tensioning, the tendons mutually affect each other. It is therefore necessary to apply tension in several stages to ensure that all tendons receive the intended force. To verify that the tendons have the intended force, the tension force of each tendon must be checked. Checks shall be carried out once the area to be checked will no longer be affected by further tensioning work. As a minimum, a distance of twice the deck width can be assumed between the tendon that is to be checked and the area where tensioning work has not yet been completed.

If during tensioning, unwanted situations occur, for example the deck begins to take on a form other than that intended, the Project Owner shall be immediately notified.

The pre-stressing bars shall be cut after the Project Owner has approved the tensioning. Remaining ends shall not be so short that the tension force check and any possible new tensioning cannot be carried out later. Paint with high zinc content shall be applied to cut surfaces.

Post-inspection of tensioning forces after one year

After one year, or at a time specified by *the special specifications*, the tension force shall be inspected and if necessary, the tendon shall be re-tensioned. The inspection shall be carried out by applying a calibrated jack, stretching the rod to the prescribed force and tightening the nut. The inspection shall be carried out on all tendons. Records shall be kept of the inspection including the tension force measured and with note of each tendon that has been checked.

- d) Tension force shall not deviate more from the intended tension force than $\pm 2.5\%$.
- e) Inspection testing of the tension steel is not considered necessary when there is a workshop certificate.
- x) Quantity shall be measured as number of pre-stressing units. Normally no specific number of tensioning steps will be planned. The bidder must evaluate this himself and include an average number of tensionings in the unit price per tension unit. Unit: pcs

86.145 Pre-treatment of stress-laminated deck for waterproofing type A3-4

- a) Comprises removal and depositing of excess creosote before laying waterproofing type A3-4. The paving work involved is included in Specification 87.1.
- c) After the wooden deck has been installed, a thin layer of sand/quarry dust/clay or other absorptive substance that is as fine-grained as possible shall be laid over the entire surface. This layer shall lie on the deck as long as possible and at least for 1 week. It shall be swept away (machine sweeping) no more than 24 hours before the laying of waterproofing type A3-4. A horizontally rotating cylinder brush with steel brushes that can dig slightly into the wooden surface must be used. Excess creosote is drawn out of the deck in this manner. The contractor is responsible for depositing waste responsibly, in accordance with Handbook 211 Waste management and current regulations.
- x) Quantity shall be measured as planned area. Unit: m²

86.146 Laying of wooden surface course on stress-laminated deck

- a) Comprises laying a wooden surface course on the stress-laminated deck including necessary waterproofing between the surface course and the load-bearing structure.
- b) Boards must be used that have a minimum thickness of 23 mm and with lengthwise edges on the board's top surface bevelled 5 mm, unless otherwise indicated in *the special specifications*.

The boards shall be pressure-treated to class AB according to Nordic Wood Preservation Council (NWPC) in NWPC Document No. 1:1998 "Nordic wood preservation classes" or be of oak or another durable type of wood. See also *the special specifications*.
- c) Surface courses of wood on stress-laminated decks require waterproofing between the surface course and the deck. This can be Topeka 4S or glued, "fat" asphalt board of a suitable quality as indicated in *the special specifications*. The timber boards shall be screwed fast to the deck. The screws shall have countersunk heads or be of another design where the screw head is sunk into the board. Nails are not acceptable as fasteners.
- x) Quantity shall be measured as planned area. Unit: m²

86.147 Laying of wooden surface course on timber joists or beams

- a) Comprises laying of a wooden surface course on timber joists or beams for use on pedestrian and bicycle bridges and on the sidewalks of road bridges.
- b) Boards must be used that have a minimum thickness of 23 mm, depending on the distance between the joists, and with lengthwise edges on the board's top surface bevelled 5 mm, unless otherwise indicated in *the special specifications*.

The boards shall be pressure-treated to class AB according to NWPC Document No. 1:1998 or be of oak or another durable type of wood. See also *the special specifications*.

- c) A surface course on joists or directly on beams requires a moisture barrier between the surface course and underlayer. This can be of asphalt board of a suitable quality as indicated in *the special specifications*. The timber boards shall be screwed fast to the underlayer. The screws shall have countersunk heads or be of another design where the screw head is sunk into the board. Nails are not acceptable as fasteners.
- x) Quantity shall be measured as planned area. Unit: m²

86.2 Stone

- a) Comprises structural components in stone such as stone walls, abutments, stone vaults, kerbstone, dressing stone, stone baskets etc.
- b-c) See Handbooks 016 Geoteknikk i veibygging [Geotechnics for road construction], 163 Vann og frostsikring i tunneler [Water and frost protection in tunnels], 182 Tørrmuring med maskin [Drywalling with machinery], 230 Steinhvelvbruer [Stone vault bridges] and *the special specifications*.
- x) Quantity shall be measured as net planned weight of mounted structures. Unit: ton

86.21 Scaffolding for stone vaults

- a-c) As in Specification 84.1 and *the special specifications*.

Scaffolding cannot be taken down before the mortar in joints has achieved 80% of its characteristic compressive strength. Underpinning must take place immediately after removing formwork before construction can continue.

- d) Account shall be taken of settlements, sagging etc. so that the tolerance requirements for the finished stone structure in *the special specifications* are met.
- x) Costs shall be given as a lump sum. Unit: LS

86.22 Formwork for stone arches

- a-e) Comprises formwork for laying stone and mortaring or pouring of joints. Otherwise as in Specification 84.2.

When building stone arches with mortar joints, wooden laths are placed in the bottom of the joints and on the free side edges as spacers and formwork for mortaring. Formwork shall end tightly against stone to prevent discolouration from the mortar. All formwork shall be removed after hardening.

- x) Quantity shall be measured as planned contact surface area between stone/mortar joint and formwork. Unit: m²

86.23 Delivery of stone

- a) Comprises removal of stone from quarry, splitting, processing, transport and storage at the construction site. See also *the special specifications*.
- b-e) As indicated in *the special specifications*.
- x) Quantity shall be measured as net planned volume of finished structure. Unit: m³

86.24 Building stone vaults and stone walls

- a) Comprises transport from storage area at the construction site and building of stone vaults and stone walls using hewn stone. Also includes mortaring joints.
Dowels grouted in stone are included in Specification 88.3245.
- b-e) Mortar shall have material properties as indicated in *the special specifications*.

General

Before construction starts, the stone shall be washed clean of all loose materials, fouling etc. All stone shall be laid in courses.

Mortaring shall only be carried out during dry weather periods while the temperature of the stone and air is above +5°C. Immediately after mortaring, fresh mortar shall be protected against drying out and precipitation. All visible surplus mortar that has leaked through the formwork or run out of the joints and discolouration that is a result of mortaring shall be removed.

Stone vaults

Any abutment joints or temporary hinges at the abutment for stone vaults are to be established in accordance with *the special specifications*.

All walling of stone vaults shall be carried out in such a way that the scaffolding is loaded symmetrically from abutments on both sides simultaneously. Stone shall be laid against wooden laths at the bottom. The laths shall function as formwork and spacers and stone must be set close together to avoid discolouration from mortar. In the area just above stone courses, spacers shall be used to achieve satisfactory joint openings.

Application of mortar to the joints in the vaults shall start at the abutment on both sides and be carried out continuously and symmetrically up to the top of the arch. All spacers and all formwork shall be removed after use.

Stone walls

Building of stone walls on abutments, spandrel walls and support walls shall be carried out in the traditional manner using mortar or as drywalling.

Spandrel walls on vault bridges shall be constructed and infill added simultaneously and symmetrically from abutments. At each side two courses shall be laid, interior work in the trough completed and filling added up to the top edge of the upper course.

Otherwise as specified in Specification 84.4, Specification 88.3 and *the special specifications*.

- x) Quantity shall be measured as net planned volume of finished structures. Unit: m³

86.241 Building of stone vaults

- a) Comprises building of stone vaults.

86.242 Building of stone walls

- a) Comprises building of stone walls with mortar joints and drystone walls.

86.2421 Building of stone walls with mortar joints

- a) Comprises building of stone walls with mortar joints

86.2422 Building of drystone walls

- a) Comprises building drystone walls.

86.25 Fill

- a) Comprises fill between the spandrel walls of arch bridges.

Geotextile fabric is included in Specification 52. Trimming of the top of the arch, casting of wedges against the upper wall and other concrete work is included in Specification 84. Membrane in the bottom of the trough, under the surface course and the surface course itself are included in Specification 87.1

- b-c) Filling shall be carried out simultaneously with building of the spandrel walls and shall be done symmetrically from the abutments on both sides. Otherwise as indicated in *the special specifications*.

- x) Quantity shall be measured as net planned volume of finished filling. Unit: m³

86.26 Delivery and laying of kerbstones

- a) Comprises delivery and laying of kerbstones

- b-c) A dry cement mortar, 1:3 or better shall be used for kerbstone joints. Otherwise as specified in Specification 88.3 and *the special specifications*.

- e) Kerbstones shall be laid in accordance with the theoretical curvature according to drawings, with no visible bends or unevenness. The kerbstone line is to be considered a "characteristic line along the length of the structure". See Specification 84. Tolerance limits for the accuracy class that is described in *the special specifications* apply to both height and lateral deviations. In addition to the tolerances specified in Specification 84 comes unevenness in hewn stone.

- x) Quantity shall be measured as net planned length of kerbstone. Unit: m

86.27 Delivery and laying of facing stone

- a) Comprises delivery and laying of facing stone

- b-c) As indicated in *the special specifications*.

- x) Quantity shall be measured as net planned area of laid facing stone. Unit: m²

86.28 Delivery and mounting of stone baskets

- a) Comprises delivery and mounting of stone baskets.

- b-c) Stone baskets shall be kept tensioned while being filled and well-packed so that the netting is tight on all sides. See also *the special specifications*.

- x) Quantity shall be measured as net planned weight of mounted stone baskets. Unit: ton

86.3 Aluminium

- a) Comprises delivery and mounting of aluminium structures in accordance with *the special specifications*.

- b-c) See "Supplementary regulations for working of aluminium" dated 17.09.2002 and *the special specifications*.

- x) Quantity shall be measured net planned weight of mounted structures. Unit: ton

87 BRIDGE SURFACING, EQUIPMENT AND SPECIAL WORK

87.1 Waterproofing, surface course, expansion joint nosings and asphalt joints

- a) Comprises waterproofing and application of asphalt pavement to bridge decks and culverts including special work at bridge deck side and end edges, connections with kerbing, edge beams or concrete parapets, guardrail posts, water outlets and asphalt pavement on abutting roads and guardrail area. Crack inducing joints, asphalt joints and expansion joint nosings are included in the specification.

If it is specified in *the special specifications*, the specification also includes temporary cover with drying or heating, and protection of materials used against harmful effects during the curing period and until protective layers are laid, so that operations can be carried out under controlled conditions, for example in winter.

The specification includes inspection of the base before work commences and necessary cleaning of pretreated surfaces to ensure that requirements are satisfied before paving work commences. If pretreatment is not satisfactory, the Project Owner shall be notified and corrective measures shall be agreed upon.

- Earthworks associated with culverts are covered by Specification 81 .
- Concrete surface course is covered in Specification 84.44.
- Pretreatment of concrete before application/paving is covered in Specification 84.6.
- Pretreatment of steel before placement is covered in Specification 85.37.
- Pretreatment of wood before installation is covered in Specification 86.145.
- Pretreatment of aluminium before installation is covered in Specification 86.3.
- Wooden surface courses are covered in Specifications 86.146 and 86.147.

Earthworks and special measures to protect waterproofing/membrane against penetration and/or tearing are covered in Specification 81. Reinforced concrete topping for the same purposes is covered in Specification 84.

- b-c) See Handbook 018 Vegbygging [Road construction], Handbook 163 Vann og frostsikring I tunneler [Water and frost protection in tunnels] and *the special specifications*.

All requirements regarding materials and execution that are set out in this or subordinated specifications are minimum requirements. If the supplier's instructions differ from these in being more stringent, the supplier's instructions shall apply.

Materials and products shall be transported, stored and used in accordance with supplier's instructions.

The type of surface that is to be paved, waterproofing, levelling layer (if any) asphalt surface course and total thickness shall be specified in *the special specifications*.

The supplier shall prepare a waterproofing and paving plan in which all work operations are described and which specifies the order of the different types of work. The paving plan shall ensure that the work is carried out under satisfactory conditions and in a manner that ensures that the final results are of satisfactory quality. The paving plan shall be submitted to the Project Owner for review and comments well before the time of execution.

There shall be no traffic on the cleaned surface and the bridge deck shall not be used for storing materials or equipment before the work is completed. Work on or near surfaces that are to be waterproofed/paved and which may contaminate the base shall not be carried out before the paving is completed.

Transport of materials and use of equipment for carrying out the paving work shall be planned and executed such that pretreated base is not contaminated and corrosion protection is not damaged. Contamination of or damage to waterproofing shall be prevented by keeping the amount of traffic, transport and use of equipment that exerts wear and tear on placed waterproofing to a minimum and proceeding as carefully as possible. There must be no loading before materials have attained sufficient strength. When asphalt surface courses are laid, transport of the materials to the paving machine shall if possible take place on already laid, levelled and compacted asphalt.

Work operations that involve heavy loads due to equipment and vehicles on placed waterproofing or asphalt surface course shall be planned and carried out so that the loading period is as short as possible, and the load is moved immediately after completion of necessary work.

Work shall also be planned and executed such that other parts of the bridge are not damaged. If this should nevertheless occur, the damage shall be remedied with materials and workmanship that result in a quality and visual impression that is as good as before the damage occurred, free of charge to the Project Owner.

- d) The evenness class of the top of the surface course shall be the same as in the abutting road and in accordance with Handbook 018 Road construction unless otherwise indicated in *the special specifications*.

If the evenness class of the abutting road is not specified, it shall be stated in *the special specifications*.

Wedging out of height deviations along the length profile shall be carried out with the following maximum relative decline (I_{max}) in relation to the theoretical road alignment:

Evenness class 1: $I_{max} = 2 ‰$
Evenness classes 2 and 3: $I_{max} = 4 ‰$
Evenness class 4: $I_{max} = 8 ‰$

- e) Inspection shall be carried out in accordance with the inspection plan drawn up by the contractor.

All factors at the fabrication/construction site that affect the quality of the waterproofing, such as wind and weather, temperature, air humidity, dewpoint, base temperature, must be recorded at least twice per shift and always when conditions change substantially. Records shall be kept and sent to the Project Owner on request.

The contractor must have at least the following handbooks, standards and equipment available for inspections:

- Handbook 015 Feltundersøkelser [Field investigations]
- Hygrometer/Psychrometer
- Air thermometer
- Surface thermometer
- Dewpoint calculator
- Sharp, thin knife
- Adhesion tests (NS-EN 1542 for concrete decks and NS-ISO 4624 for steel decks)

Before the work starts the contractor shall inspect pretreated surfaces visually and measure the moisture content and adhesion to the base.

All damage and defects in the base shall be repaired and the work necessary to provide satisfactory adhesion shall be completed. The surface shall be clean and dry, free of loose particles, dirt, fouling, grease and oil. Concrete decks shall be pretreated in accordance with Specification 84.62 or 84.63 and cleaned of slurry, mortar spills, curing compound etc. Steel decks shall be pretreated in accordance with Specification 85.37. Wooden decks shall be pretreated in accordance with Specification 86.145 and shall be free of surplus creosote, and there shall be no signs of further seepage.

When the paving work is to be carried out as a separate contract, the contractor shall give the Project Owner written confirmation that the base has been inspected and that the pretreatment is satisfactory. If this is not the case, the Project Owner shall be informed in writing of any deficiencies so that the Project Owner can take corrective action. This shall be repeated until confirmation can be given.

The adhesion of laid and hardened epoxy on concrete shall be tested with pull-off tests in accordance with Handbook 015 Field investigations, Method 15.541 (NS-EN 1542). 1 test consisting of 3 individual pull-offs shall be carried out for each 50 m² or part thereof. If the last 5 tests satisfy the requirement, the testing frequency can be reduced to 1 test per 500 m².

The adhesion requirement is a minimum of 1.5 MPa for each test, no single pull-off to be less than 1.3 MPa.

The moisture content of the concrete base shall be tested if it influences the adhesion of the tack coat or waterproofing. The moisture content shall lie under the upper limit stipulated by the product supplier.

The moisture content of concrete bases shall be tested in accordance with Handbook 015 Field investigations, method 15.543, if the product supplier does not specify another method.

Tests in connection with the laying of asphalt surface courses shall be carried out in accordance with currently applicable contractual basis for asphalt paving works for the Norwegian Public Roads Administration.

Test of particle size curve, binder content and hardness of mastic asphalt for waterproofing such as Topeka 4S (Top 4S) delivered in boiler:

In each sampling round, one sample shall be taken for the Project Owner and one for the contractor. The contractor may use his sample in production control if he wishes to. During the work, at least one sample of polymer-modified bitumen emulsion PmBE60 (C60BP3) and one sample of Topeka 4S shall be taken per bridge. With large bridges, one sample per boiler shall be taken, and of these one sample per 1000 m² of bridge deck shall be analysed to determine the composition (binder content and aggregate grading) and hardness as measured by indentation test in accordance with Handbook 014 Laboratorieundersøkelser [Laboratory tests], method 14.5582 (NS-EN 12697-20). Mass tests shall be taken from a half-full boiler in accordance with Handbook 015 Field investigations, method 15.3412. Material consumption shall be recorded and reported.

- x) Quantity shall be measured as planned weight of waterproofing and surface course. Unit: ton

87.11 Temporary cover and climate control

- a) Comprises temporary cover and climate control with dehumidifying and heating and protection of materials used against harmful effects during the curing period and until protective layers are laid so that operations can be carried out under controlled conditions.

The minimum length of temporary cover shall be indicated in *the special specifications*, and likewise any constraints due to wind load on the bridge.

- b) Temporary cover shall be of a size (length, breadth) and design that allows a work operation to be carried out across the entire breadth of the bridge deck. It shall be possible to close the tent completely and it must be strong enough and well enough secured to withstand prevailing wind load. Temporary cover shall also be so watertight and insulating that it is possible to air-condition to the desired temperature and humidity.

Heating and dehumidifying equipment shall have satisfactory capacity in relation to climatic conditions and tent volume. Equipment shall be used in such a way that oil, grease, exhaust fumes etc. do not contaminate the subgrade before the pavement is laid.

- c) The final amount of temporary cover and climate control used shall be agreed with the Project Manager far enough ahead of time for satisfactory conditions to be achieved. The principles for anchoring components in the bridge shall be submitted to the Project Owner for review and comments in good time before use. Anchoring shall be carried out in such a way that the structure is not damaged. Special care shall be exercised to ensure that corrosion protection/surface treatment is not damaged. In the unlikely event that damage does occur, it shall be repaired free of cost for the Project Owner and with materials and execution that result in a quality that is equivalent to an undamaged structure.
- x) Quantity shall be measured as temporary covered and air conditioned area. Unit: m²

87.111 Preparedness

- a) Comprises preparedness to have tents for temporary cover and dehumidifying and heating equipment ready for use if it should be necessary in order to achieve satisfactory execution.
- x) Quantity shall be measured as area of bridge deck for which temporary cover is kept ready. Unit: m²

87.112 Temporary cover

- a) Comprises all transport, setting up, maintenance, moving and taking down of tents, temporary cover and climate control, and keeping them in operational condition during the curing period and until a protective layer is in place so that operations can be carried out under controlled conditions.
- x) Quantity shall be measured as area of temporary cover. Unit: m²

87.113 Climate control

- a) Comprises climate control with dehumidifying and heating and protection of materials used against harmful effects during the curing period and until protective layers are in place so that operations can be carried out under controlled conditions.
- x) Quantity shall be measured as climate-controlled area. Unit: m²

87.12 Tack coat for surfacing class A1

- a) Comprises tack coat for surfacing class A1 – Asphalt surface course directly onto concrete deck.
If Specification 87.16 with underlying specifications is not listed in the bill of quantities, all connections are also included.
- b) PmBE60 (C60BP3) or other suitable polymer-modified bitumen emulsion shall be used as tack coat. PmBE60 (C60BP3) shall satisfy requirements as described in Specification 87.14.
- c) The tack coat shall be applied to the bridge deck in a quantity of 0.2-0.5 kg/m², adapted to the surface structure and absorption capacity of the deck. Kerbing/edge beams shall be sealed by applying tack coat to approx. 10 cm up on the sides and, after asphalt paving, in a breadth of 30 cm outwards from the kerbing/edge beams.
Further paving work shall be carried out after complete breaking of the tack coat. Connections shall be designed according to Specification 87.16 and relevant sub-specifications.
- x) Quantity shall be measured as planned area. Unit: m²

87.13 Simplified waterproofing – A2

- a) Comprises simplified waterproofing type A2-1 with low viscosity epoxy or type A2-2 with polymer-modified bitumen emulsion PmBE60 (C60BP3) on concrete decks.
If Specification 87.16 with underlying specifications is not listed in the bill of quantities, all connections are also included.
- b) Fine sand for sanding shall be clean and of a wear resistant rock type. Fine sand shall have a particle size of 0.5-1.5 mm and be free of dust, dry and free of coating.
Low viscosity epoxy for waterproofing type A2-1 shall be free of solvents from supplier and be used undiluted. It shall satisfy the same requirements as the low viscosity epoxy for waterproofing type A3-1, Specification 87.14.
Polymer-modified bitumen emulsion PmBE60 (C60BP3) for waterproofing type A2-2 shall satisfy the requirements specified in Specification 87.14.

- c) Air temperature shall be over +10°C. Relative humidity shall be lower than 80%. The temperature of the base material shall be at least 3°C above the dewpoint at the time of application.

Connections shall be made as described in Specification 87.16 and relevant sub-specifications.

Simplified waterproofing type A2-1 with low viscosity epoxy

Epoxy shall be applied with a brush, roller, squeegee or similar. A special spray gun can also be used, but the first coat must then be brushed thoroughly to reduce the extent of pinholes through the next layer. The working pressure of the spray gun shall be created by liquid pumps so that propulsive gas does not come into contact with epoxy material before it leaves the mouth piece nozzle.

Low viscosity epoxy shall be applied to the concrete surface in a quantity of 0.3-0.5 kg/m², depending on the surface structure and absorptive capacity of the deck. Surfaces to which it is not possible to apply the next layer wet on wet shall be sanded with fine sand while the surface is wet.

Epoxy shall be distributed evenly over the entire surface. At contacts with previously applied epoxy, there shall be an overlap of at least 10 cm, and a zone shall be set off for a further overlap with epoxy in relation to the next application round.

On other surfaces, the next layer shall be applied wet on wet in an amount of approximately 0.3 kg/m², depending on the saturation from the first layer. Before hardening, the surface shall be sanded with fine sand in a quantity of 2.0 kg/m² so that the surface resembles sandpaper. After hardening, all surplus sand shall be removed.

PmBE60 (C60BP3) tack coat shall be applied to the sanded, cleaned and dry surface and 10 cm up the kerbing/edge beam and, after applying asphalt, to a distance of 30-50 cm out from the kerbing/edge beam, using a spray gun or brush in a quantity of 0.3-0.4 kg/m² depending on the surface structure and absorptive capacity of the deck. There must be no pools or untreated areas. The surface shall be immediately sanded with fine sand. When the tack coat has broken, normally after 1-6 hours, surplus shall be removed using compressed air.

Simplified waterproofing type A2-2 with polymer-modified bitumen emulsion PmBE60 (C60BP3)

PmBE60 (C60BP3) tack coat shall be applied to the cleaned and dry surface and 10 cm up the kerbing/edge beams and, after applying asphalt, to a distance of 30-50 cm out from the kerbing/edge beam, using a spray gun or brush, in a quantity of 0.3-0.5 kg/m² depending on the surface structure and absorptive capacity of the deck. There must be no pools or untreated areas. The surface shall be sanded immediately with fine sand in a quantity of 1.0-2.0 kg/m². When the tack coat has broken, normally after 1-6 hours, surplus sand shall be removed using compressed air.

A new layer of PmBE60 tack coat shall then be applied in a similar manner using a somewhat reduced quantity of 0.2-0.4 kg/m². The surface shall again be sanded immediately with fine sand in a quantity of 1.0-2.0 kg/m². When the tack coat has broken, normally after 1-6 hours, surplus sand shall be removed using compressed air.

- x) Quantity shall be measured as planned area. Unit: m²

87.131 Simplified waterproofing type A2-1

- a) Comprises simplified waterproofing type A2-1 with low viscosity epoxy on bridge decks.

- x) Quantity shall be measured as planned area. Unit: m²

87.132 Simplified waterproofing type A2-2

- a) Comprises simplified waterproofing type A2-2 with sealing with polymer-modified bitumen emulsion PmBE60 (C60BP3) on bridge decks.

- x) Quantity shall be measured as planned area. Unit: m²

87.14 Full waterproofing – A3

- a) Comprises full waterproofing type A3-1 with epoxy and mastic asphalt, type A3-2 with prefabricated membrane, type A-3 with polyurethane or type A3-4 with PmB-based materials.

Also applies to waterproofing of bridge decks and culverts above and below the water-table. Any protection of waterproofing on culverts is covered by Specifications 81, 84 and 87.15.

If Specification 87.16 with underlying specifications is not listed in the bill of quantities, all connections are also included.

- b) Fine sand for sanding shall be clean, and of a wear resistant rock type. Fine sand shall have a particle size of 0.5-1.5 mm and be free of dust, dry and free of coating.

Epoxy for waterproofing type A3-1 shall satisfy the following requirements:

Epoxy shall come free of solvents from the supplier and be used undiluted. The first layer shall be low viscosity epoxy for best possible penetration and impregnation of the concrete base. The second layer shall act as a seal.

Low viscosity epoxy and sealing epoxy shall satisfy the requirements in Table 87.1-1.

Testing	Method	Unit	Requirements low-viscosity epoxy ²⁾ 1st layer	Requirements sealing epoxy 2nd layer	Tolerances ³⁾
Viscosity of components ⁴⁾	NS-EN ISO 3219	mPa·s	To be stated	To be stated	±20%
Component densities	NS-EN ISO 2811-1	g/cm ³	To be stated	To be stated	±3%
Viscosity of mixture ⁴⁾	NS-EN ISO 3219	mPa·s	Max. 500 at 20°C	500-2000 at 20°C	±20%
Pot-life ⁵⁾	NS-EN ISO 9514	Minutes	To be stated	To be stated	±15%
Content of volatile components	NS-EN ISO 3251	Mass %	Max. 2.5	Max. 2.5	±0.15%
Hardness	NS-EN ISO 868	Shore D	Min. 35	Min. 35	±3 units after 7 days
Adhesion to concrete	NS-EN ISO 1542	N/mm ² (MPa)	Min. 1.5	Min. 1.5	

1) The table is based on properties and test methods defined in NS-EN 1504-2.

2) Low viscosity epoxy shall be water-resistant and solvent free.

3) Permitted deviation from value specified by manufacturer.

4) Temperature and shear rate shall be stated.

5) Test conditions shall be specified. The pot-life shall be sufficient for the job. Insulating mastic asphalt for waterproofing type A3-1 shall satisfy the requirements in Handbook 018 Road construction.

Prefabricated membrane for waterproofing type A3-2 shall satisfy the requirements in Table 87.1-2.

Characteristic	Testing	Method	Unit	Requirements
Visible defect	Visual	NS-EN 1850-1	-	No visible defect
Thickness	Thickness	NS-EN 1849-1	mm	> 4.5
Tensile strength and extension	Tensile strength (L/T) ²⁾	NS-EN 12311-1	N/50 mm	> 800/ > 800
	Extension (L/T) ²⁾			% ± 15 > 30/ > 30
Watertightness	Dynamic water pressure	NS-EN 14694	-	Watertight
Flexibility when cold	Flexibility at low temperature	NS-EN 1109	%	< - 20
Dimension stability	Max. change after 24 hours at 80°C	NS-EN 1107-1	N/mm ²	-0.4 < x < + 0.25
Adhesion strength	Bond strength, Type 1 ³⁾	NS-EN 13596	N/mm ²	0 ≥ 0.5
Shear strength	Shear strength	NS-EN 13653	N/mm ²	0 ≥ 0.7

1) The table is based on the properties and test methods defined in prEN 14695.

2) L = along the length, T = across the width

3) Type 1 is adhesion between membrane and concrete.

Polyurethane for waterproofing type A3-3 shall satisfy the following requirements:

Documentation or a guarantee is required that the product can be used under the climatic conditions in question, and that it functions together with the other materials that are intended to be used in the structure.

Polymer-modified bitumen that is used in Top 4S shall satisfy the following requirements:

The binder shall be designated and documented according to methods in NS-EN 14023. It shall have an elastic recovery at 10°C of at least 75% and a softening point of at least 80°C. Fraass breaking point shall be maximum of -20°C. In order to meet the requirements, the binder must normally have minimum 5% SBS polymer content.

Polymer-modified bitumen emulsion PmBE60 (C60BP3) for waterproofing type A3-4 shall satisfy the following requirements:

The base binder shall have a softening point of a minimum of 60°C and an elastic recovery at 10°C of a minimum of 75%. The emulsion shall be designated and documented according to the methods in NS-EN 13808 and NS-EN 14023. The emulsion shall have a viscosity (4 mm, 40°C) of 5-10 seconds and a binder content of 61 ± 1%.

With effect from 2008, PmBE60 will be designated C60BP3 and shall be documented according to the methods in NS-EN 13808 and NS-EN 14023.

Topeka 45 for waterproofing type A3-4 shall satisfy requirements for type of material specified in Handbook 018 Road construction.

Membranes on culverts above and below the groundwater level shall satisfy the requirements in Handbook 163 Water and frost protection in tunnels (2006). Waterproofing type A3-4 can be used on the horizontal surfaces of culverts. The waterproofing must then be given appropriate protection against penetration from overlying masses such as a layer of asphalt or mesh-reinforced concrete topping.

Connectors shall satisfy the requirements in Specification 87.16.

- c) Air temperature shall be over +10°C. Relative humidity shall be lower than 80% for waterproofing types A3-1, A3-2 and A3-4 and lower than 70% for waterproofing type A3-3. The temperature of the base material shall be at least 3°C above the dewpoint during application. There must be no exposure to strong sun and wide temperature fluctuations. The work shall be carried out at falling temperatures.

The material supplier's instructions regarding placing or installation shall be form the basis for the application. Connections shall be designed as described in Specification 87.16 and relevant sub-specifications.

Full waterproofing type A3-1 with epoxy and insulating mastic asphalt.

Epoxy shall be applied in two coats by means of roller, brush, squeegee or similar. A special spray gun can also be used, but the first coat must then be brushed thoroughly to reduce the quantity of pinholes through the next layer. The working pressure of the special spray gun shall be created by liquid pumps so that propulsive gas does not come into contact with epoxy material before it leaves the mouth piece nozzle.

Epoxy shall be distributed evenly over the entire surface. At contacts with previously applied epoxy, there shall be an overlap of at least 10 cm, and a zone shall be set off for a further overlap with epoxy in relation to the next application round.

Material consumption shall be approx. 0.5 kg/m² for the first layer and approx. 1.0 kg/m² for the second layer that is applied wet on wet on the first layer.

The second layer shall be sanded with fine sand in a quantity of 1-2 kg/m². Where there is a risk of slippage between the epoxy and the insulating mastic asphalt because of a gradient or special traffic conditions, an increased particle size of 2-4 mm can be used, but with a maximum particle size of 4 mm.

If there is a risk due to weather or other factors that the first layer will have hardened before the second layer is applied, both layers shall be sanded.

The sanding shall be carried out so that the finished surface looks like coarse sandpaper with sparse but protruding stone particles. The stone particles shall not penetrate both layers.

Holes in the epoxy coating that penetrate both layers shall be repaired by means of local application of epoxy which is sanded. Application of insulating mastic asphalt shall not start before the epoxy layers have hardened satisfactorily.

Insulating mastic asphalt shall be applied manually or with a paving machine to a thickness of 1-5 mm. The mass shall be placed directly against kerbing or edge beams.

Placing shall start at the highest point on the bridge deck to avoid water accumulating against the leading edge edge which is to form a joint with the next stage.

When joints are made the edge of the already placed mass shall be heated with a joint heater and the joints shall be carefully smoothed manually. In the event of defects in the joint, if the joint area has a sufficiently high temperature, new, hot mass shall be added and smoothed to full homogeneity in the joint. If the temperature is too low, the joint shall be cautiously heated up with a propane flame, new hot material added and the joint smoothed to full homogeneity.

Because of the high risk of blister formation on the unprotected insulating layer, the surface course shall be laid as soon as possible, and 3 days at the latest after the insulating mastic asphalt has been placed.

Full waterproofing type A3-2 with prefabricated membrane

The concrete base shall be free of burrs and fins that will prevent full contact with the membrane.

Tack coating shall be carried out in accordance with supplier's specifications. There shall be good cover without untreated areas, but there must be no pools of tack coating. Tack-coated surface shall be completely dry before the membrane is rolled out.

Membrane shall be laid out along the length of the bridge deck, from the lowest to the highest point in both crosswise and lengthwise directions so that overlap at joints does not prevent water run-off.

Overlap along the length of the pavement shall be at least 10 cm and in joints across the pavement at least 15 cm. The overlap shall be tacked or welded carefully and have the same characteristics as the membrane generally.

The membrane shall be tacked carefully at all connections with kerbing or edge beams to prevent water ingress.

When using two-layer membrane, the second layer shall be tacked or welded to the underlying layer in a manner similar to the way the first was tacked/welded, provided supplier's laying instructions do not specify otherwise. The layers shall be displaced in relation to one another so that overlaps are at least 20 cm apart.

Membrane shall be covered by a protective layer as soon as possible.

Laying of membrane with mopping coat bitumen

Mopping coat bitumen shall be warmed up in a thermostatically controlled bitumen boiler. If oxidised bitumen is used as binder, the temperature shall not exceed 220°C. If polymer-modified bitumen is used, supplier's temperature constraints shall be observed.

Membrane shall be rolled out in a wave of hot, low viscosity mopping coat bitumen on a tack-coated, dry, clean concrete surface. The mopping coat bitumen must be pressed forward in front of the roll in full breadth in order to achieve satisfactory adhesion to the base without trapped air pockets. Consumption shall normally be 1.5-2.0 kg/m².

In the event of stiff membranes or in cold water it may be necessary to spread on an even layer of heated binder first. Waterproofing is then welded onto the base using a propane burner.

Laying of welded membrane

The polymer-based asphalt membrane shall have a welded underside, and the asphalt membrane shall be welded to the base with a propane burner mounted on the paving machine. The bitumen must not be overheated.

See also supplier's instructions.

Laying of self-adhesive membrane

The membrane shall be placed in the correct position and the protective paper on the contact surface removed during laying. After fitting and rolling out, the adhesive surface must be pressed well down against the base. To ensure satisfactory adhesion, particularly at the joints, it must be rolled with a light manual roller at the end.

If there is water on the membrane that must be removed before further paving, it shall be dried up by natural means and without the use of heating. A propane burner must not be used.

See also supplier's instructions.

Protective layer

A dense-graded asphalt concrete AC 4 (Ab 4) according to Handbook 018 Road construction may be used as a protective layer. Any tack-coating between the membrane and the protective layer shall be applied according to supplier's instructions.

The protective layer shall be laid in a thickness of 15-20 mm when compacted.

The temperature of the mass shall not exceed 140°C. The mass shall be laid manually or with a paving machine that does not damage the waterproofing. If a paving machine is used, a little asphalt shall be laid to protect the waterproofing in the end edge so that it does not get displaced when the paving machine is started up. The mass shall be laid directly against kerbing or edge beams.

Compaction by means of rolling shall be carried out carefully. A light-weight rolling compactor shall be used for the first passes so that the membrane is not damaged, but the protective layer shall be compacted to make it as dense as possible.

Full waterproofing type A3-3 with polyurethane

Primer is applied with a roller, brush or similar in a quantity of 0.2 kg/m² and in accordance with supplier's specifications.

Waterproofing shall be applied immediately after evaporation of solvent from the primed surface. The material shall be applied with a two-component spray in a thickness of approx. 2 mm. The bridge deck and to the external corner of the edge beams and to approx. 10 cm up on the guardrail posts shall be treated in one operation.

After the polyurethane material is fully cured, a layer of Topeka 45 or mastic asphalt (Sta 2/Sta 4) shall be laid in a thickness of 10 ± 5 mm as an adhesion layer against overlying asphalt layers.

Full waterproofing type A3-4 with polymer-modified bitumen (PmB) based materials

On concrete deck:

PmBE60 (C60BP3) tack coat is applied with a spray gun or brush to clean, dry surfaces and 10 cm up on the kerbing/edge beams, in a quantity of 0.3-0.5 kg/m², depending on the surface structure and absorptive capacity of the deck. There must be no pools or untreated areas. The surface shall be sanded immediately with fine sand in a quantity of 1.0-2.0 kg/m². When the upper surface is dry, normally after 3-24 hours, surplus sand shall be removed using compressed air.

On a steel deck:

The quantity of PmBE60 (C60BP3) tack coat shall be reduced to 0.1-0.15 kg/m². In other respects as for concrete decks.

Topeka 4S shall be laid on fully broken tack coat and on a dry and clean base in a thickness of 12 mm. The mass is self-compacting and is laid right up to vertical surfaces. It shall be laid manually or with a paving machine and the temperature of the mass must not exceed 190°C.

No vehicles other than those that are necessary for further paving work shall be allowed on the insulating layer. Other construction traffic shall be avoided.

Binder course and/or surface course shall be laid a maximum of 3 days after waterproofing has been carried out.

To avoid stickiness on the surface on hot days, Topeka 4S can be sanded with dry, dust-free fine sand with a particle size of 0.5-1.5 mm in a quantity of 1-2.0 kg/m² before the surface course is laid. The quantity of sand must not be large enough to reduce adhesion between Topeka 4S and surface course.

d) Insulating mastic asphalt for full waterproofing type A3-1 shall be laid with a thickness of 15 ± 5 mm.

Topeka 4S for full insulation type A3-4 shall be laid with a thickness of 12 ± 3 mm.

x) Quantity shall be measured as planned area. Unit: m²

87.141 Waterproofing type A3-1

a) Comprises waterproofing type A3-1 with epoxy and insulation mastic asphalt on concrete decks.

x) Quantity shall be measured as planned area. Unit: m²

87.142 Waterproofing type A3-2

a) Comprises waterproofing type A3-2 with prefabricated membrane and protective layer on concrete decks.

x) Quantity shall be measured as planned area. Unit: m²

87.143 Waterproofing type A3-3

a) Comprises waterproofing type A3-3 with polyurethane and binding layer on concrete decks.

x) Quantity shall be measured as planned area. Unit: m²

87.144 Waterproofing type A3-4

a) Comprises waterproofing type A3-4 with PmBE60 (C60BP3) and Topeka 4S on concrete, steel and timber decks.

x) Quantity shall be measured as planned area. Unit: m²

87.145 Membrane above groundwater level on culverts

a) Comprises membrane above groundwater level on culverts.

b-e) See Handbook 163 Water and frost protection in tunnels and *the special specifications*.

x) Quantity shall be measured as planned area. Unit: m²

87.146 Cavity drain membrane

a) Comprises cavity drain membranes on walls in abutments, culverts, protective walls etc. above the groundwater level.

b-c) When backfilling takes place, fill and if necessary geotextile shall be used against studded membrane to avoid penetration and/or tearing down when filling/compaction takes place.

x) Quantity shall be measured as planned area. Unit: m²

87.147 Membrane below groundwater level on culverts

a) Comprises membrane below groundwater level on culverts.

b-e) See Handbook 163 Water and frost protection in tunnels and *the special specifications*.

x) Quantity shall be measured as planned area. Unit: m²

87.15 Levelling layer, binder course and asphalt surface course

a) Comprises levelling layer, binder course and asphalt surface course on tack coat or waterproofing.

b) As in Handbook 018 Road construction.

c) If necessary, or if indicated in *the special specifications*, a levelling layer shall be laid before the surface course.

A levelling layer shall be laid between waterproofing and asphalt surface course. Asphalt concrete (AC) or dense graded mix shall be used with an upper nominal particle size of from 8 to 16 mm depending on the thickness of the levelling layer.

Binder course and surface course shall be chosen according to the same criteria as for abutting roads. Cavities in the surface course shall be close to the lowest permissible threshold value for the surface course type in question.

When application of asphalt commences and when stages are finished, a wedge shall be laid if necessary to take up the difference between the upper surface of the bridge deck/waterproofing and the asphalt surface course so that edges or waterproofing are not damaged in connection with further work. The wedge shall be laid against the adhesion-preventing layer to enable simple removal before a permanent asphalt surface course is laid.

For thicknesses of more than 80 mm, asphalt surface course shall be laid in two rounds. See also Handbook 018 Road construction.

d-e) As in Handbook 018 Road construction and the applicable contractual basis for asphalt paving works for the Norwegian Public Roads Administration.

x) Quantity shall be measured as planned mass. Unit: ton

87.151 Asphalt levelling layer

a) Comprises levelling layer on tack coat or waterproofing.

b) Unless otherwise indicated in *the special specifications*, asphalt concrete (AC) shall be used in levelling layers.

x) Quantity shall be measured as planned mass. Unit: ton

87.152 Asphalt binder/surface course

a) Covers asphalt such as mastic asphalt (MA), Topeka (Top) stone mastic asphalt (SMA), asphalt concrete (AC) or asphalt concrete for low volume roads AC (Agb) in binder course/surface course laid on tack coat, waterproofing or levelling layer.

b) Unless otherwise indicated in *the special specifications*, asphalt concrete (AC) shall be used in binder courses.

x) Quantity shall be measured as planned mass. Unit: ton

87.1521 Mastic asphalt

a) Comprises mastic asphalt in binder course if this is specified in *the special specifications*, and in surface courses laid on tack coat, waterproofing, levelling layer or binder course.

x) Quantity shall be measured as planned mass. Unit: ton

87.1 522 Topeka

a) Comprises Topeka in binder course if this is specified in *the special specifications*, and in surface courses laid on tack coat, waterproofing, levelling layer or binder course.

x) Quantity shall be measured as planned mass. Unit: ton

87.1523 Stone mastic asphalt

a) Comprises stone mastic asphalt in binder course if this is specified in *the special specifications*, and in surface courses laid on tack coat, waterproofing, levelling layer or binder course.

x) Quantity shall be measured as planned mass. Unit: ton

87.1524 Asphalt concrete (AC)

a) Comprises asphalt concrete in binder course and surface course laid on tack coat, waterproofing or levelling layer.

x) Quantity shall be measured as planned mass. Unit: ton

87.1525 Asphalt concrete for low volume roads AC(Agb)

a) Comprises delivery and laying of asphalt concrete AC(Agb) mixed in binder courses if this is specified in *the special specifications*, and in surface courses laid on tack coat, waterproofing, levelling layer or binder course.

x) Quantity shall be measured as planned mass. Unit: ton

87.153 Thin surface course and friction surfaces

b-e) As in *the special specifications*. The surface shall be sanded with appropriate material in order to secure satisfactory friction.

x) Quantity shall be measured as planned area. Unit: m²

87.16 Connections

- a) Comprises special works with waterproofing and surface course at bridge deck side and end edges, connections with kerbing, edge beams or concrete parapets, guardrail posts, water outlets and with asphalt surface courses on abutting roads as well as laying in parapet area when this is not included in other specifications.
- b-e) End details that involve reduced reinforcement cover and the use of non-durable materials such as wood are not permitted.

Accessories and anchors shall be of durable materials and well protected against corrosion, and not come into conflict with future operations and maintenance. Terminal strips and fasteners for securing or terminating cavity drain membrane, prefabricated membrane etc., shall be delivered in corrosion-resistant stainless steel or in steel that has been galvanized according to Specification 85.342.

Corrosion-resistant stainless steel shall be delivered in accordance with NS-EN 10088, number 1.4435, 1.4436 or similar with fasteners (bolted connections, clamps/brackets etc.) of corrosion-resistant stainless steel delivered according to NS-EN ISO 3506, quality A4-80 or similar.

Cavity drain membranes and prefabricated membranes may not be fixed in place with adhesive or sealing compound without terminal strips etc.

See also Specifications 87.12, 87.13, 87.14, 87.15 and *the special specifications*.

- x) Costs shall be given as a lump sum. Unit: LS

87.161 Edge without edge beam/kerbing

- a) Comprises edge of waterproofing/surface course on bridge sides without edge beam/kerbing.

Laying of waterproofing and surface course in parapet area is included in Specification 87.164.

- c) Waterproofing and protective layers shall be brought right to the phasing out of the outer edge of the bridge deck. If necessary, formwork consisting of appropriate L-shaped steel or similar shall be used to ensure that mass does not flow out over the side of the bridge deck. The formwork shall then be installed inside the chamfered edge and removed as soon as possible after the laying of the waterproofing has finished. If necessary it can be heated with a propane burner to release it from the base.

Asphalt shall be laid with an edge approx. 5 cm in on the waterproofing and chamfered edge to full height.

- x) Quantity shall be measured as length of edge. Unit: m

87.162 Connection with edge beam/kerbing

- a) Comprises connection between waterproofing/surface course and kerbing or edge beams.

- c) **Surfacing class A1 Asphalt surface course and A2 Simplified waterproofing**
Immediately after laying of the surface course, the upper edge of the surface course is sealed for a breadth of 40 cm from the kerbing or edge beam through repeated applications of PmBE60 (C60BP3) until saturation. The surface is then sanded with dry, dust-free fine sand with a particle size of 0.5-1.5 mm until there is surplus sand on the surface (loose sand) to accelerate breaking and prevent undesired adhesion when there is traffic on the bridge.

Surfacing class A3 Full waterproofing

Formwork shall be used in the form of appropriate steel profiles or similar which are easy to remove after laying of the surface course. Formwork shall be built out 20 mm from vertical surfaces on kerbing/edge beams and be level with the waterproofing/protective layer. Immediately after laying of the surface course, the formwork shall be removed. If necessary it can be heated with a propane burner to release it from the base. Joints shall be immediately filled with Topeka 4S or the equivalent and shaped with a hollow wedge at the top with a slope from the kerbing/edge beam towards the surface course so that water is led away.

Joints shall be clean and dry when they are filled.

If prefabricated membrane is used, an alternative solution provided by supplier can be used for the connection with kerbing/edge beam. This shall be presented to the Project Owner for comment before the work is carried out.

Solutions that include slotting in and/or use of accessories for establishing a connection may not be used.

When surfacing class A3 Full waterproofing type A3-3 is used, a special connection with the edge beam is not necessary, but the insulation shall be well compacted against the edge beam.

- x) Quantity shall be measured as length of connection. Unit: m

87.163 Edge in bridge ends and connection with joints

- a) Comprises edge of paving in bridge ends, connection between paving and joints, expansion joint nosings, butt joints and wedging out towards paving on abutting roads.

b-e) **Bridge ends (abutment-less solution)**

Waterproofing shall be taken right down to the lower face of the bridge end or upper face of the transition slab. Waterproofing shall be of the same class as on bridge decks, but if it is not possible to lay a full system on vertical surfaces, another appropriate type shall be used, such as prefabricated waterproofing.

Crack inducing joints

The exact position of crack inducing joints shall be marked. Insulating layers and asphalt shall be laid continuously over the joint and compacted.

Asphalt joints

Concrete surfaces that are to lie against a steel plate over a joint opening when an asphalt joint is built shall be levelled if necessary with an appropriate cemented-based material to provide a good contact. Trial installation of the steel plate shall take place to check that it lies against the base and that the design is fitted to the geometry of the upper face bridge deck and if relevant continues up the kerbing or edge beam.

Epoxy, PmBE60 (C60BP3) or polyurethane is continued right up to the joint opening and as far down in the opening as possible. Prefabricated waterproofing is only laid up to the joint opening.

Joint openings are sealed with fill material of polystyrene, hemp rope or similar and covered with appropriate temporary formwork so that the mass does not penetrate down into the joint opening. The exact position of joint openings shall be marked.

An adhesion-preventing layer shall be laid against the base across the breadth of the asphalt joint. The layer may, for example, consist of a thin steel plate on a sand layer against the waterproofing, the purpose being to enable surface course to be removed after sawing without harm to the waterproofing. The positioning of the saw cuts in the transition between asphalt joint and surface course must be marked. (The breadth of the asphalt joint shall be indicated by *the special specifications* in Specification 87.172).

Insulating layers and asphalt shall be laid continuously over the joint and compacted.

Expansion joint nosings at joint structures

Waterproofing and any protective layer shall be laid in its entirety up to the recess (joint bed) for casting in place of the joint structure.

An adhesion-preventing layer shall be laid against the base behind the recess for joint bed in the entire breadth of the expansion joint nosing. The layer may, for example, consist of a thin steel plate and a sand layer against the waterproofing, the purpose being to enable surface course to be removed after sawing without damage to the waterproofing. The position of the saw cuts in the transition between expansion joint nosing and surface course must be marked. (The breadth of the expansion joint nosing is 60 cm or as indicated in *the special specifications* in Specification 87.18).

Joint bed shall be temporarily covered so that paving equipment can pass and, depending on the size of the joint bed, it shall be asphalted continuously over and slightly onto surfaces which are to be laid subsequently with joint nosing.

Wedging out

Topeka 4S, AC 8 or similar material shall be used for wedging out. The quality of the mass and stone material shall be adapted to the ADT in question. Top 4S shall be strewn with pre-coated chippings 4/8 or 8/11 mm.

When wedging out takes place, the base shall be cleaned and dried to ensure good adhesion. Tack coat shall be used. To make the surface non-adhesive, it shall be strewn with chippings 8/11 mm after laying is completed. All loose material shall be removed.

Unless otherwise indicated in *the special specifications*, wedging out shall be designed to satisfy tolerance class 3 with a slope into the wheel rut of 2 mm per metre of wedging out.

Butt joints

Surfacing from the bridge must be extended well onto abutting roads before a butt joint is established.

Butt joints shall be established by milling a laying edge against abutting surfacing at right angles to the road. A milling depth of approx. 50 mm which is reduced to 0 over 5-6 m. The surfaces shall be cleaned and adhesion shall take place against milled surface and paving from the bridge shall be laid against sawn surface and worked so that the surface becomes completely plane without height irregularities or angular deviations.

If surfacing work is completed on the bridge first, butt joints shall be established similarly, but with sawing of the paving on the bridge side.

There must be constant monitoring of the sawing depth to ensure that the cut does not damage structural concrete or load-bearing reinforcement.

- x) Quantity shall be measured as length of edge/connection. Unit: m

- 87.1631 Edges at bridge ends**
- a) Comprises edges of surfacing at bridge ends in abutment-free design.
 - x) Quantity shall be measured as planned vertical area of bridge end. Unit: m²
- 87.1632 Connection with crack inducing joints**
- a) Comprises connections with crack inducing joint.
 - x) As in Specification 87.163. Unit: m
- 87.1633 Connection at asphalt joints**
- a) Comprises connections at asphalt joints.
 - x) As in Specification 87.163. Unit: m
- 87.1634 Connection at expansion joint nosings/joint structures**
- a) Comprises connections at expansion joint nosings/structures
 - x) As in Specification 87.163. Unit: m
- 87.1635 Butt joints**
- a) Comprises connections at butt joints.
 - x) Quantity shall be measured as area of butt joints. Unit: m²
- 87.1636 Wedging out**
- a) Comprises wedging out of wheel ruts in existing surface course.
 - x) Quantity shall be measured as volume of placed wedging out. Unit: litre
- 87.164 Connection with guardrail posts and laying in parapet area**
- a) Comprises connection of waterproofing/surface course with guardrail posts and laying in parapet area.

The specification is used when the inner or outer parapet is embedded in the bridge deck. (No kerbing/edge beam).
 - b) Self-compacting Topeka 45, mastic asphalt or similar is used when laying parapet area manually.
 - c) Guardrail posts shall be erected before the laying of waterproofing and surface course in parapet area. Base plates shall be grouted or guardrail posts concreted in recesses. Grout shall be cured.

Waterproofing shall be applied in the parapet area in the same way as on the rest of the bridge deck. Tack coat shall be applied to underlying concrete and base plates with bolts or the upper face of cast concrete and guardrail post up to the level of the top of the surface course. The same applies when waterproofing with polyurethane is used.

When the surfacing is laid, machine laying stops at the parapet area so that a stripe of at least 40 cm centred on the guardrail posts remains.

An appropriate paving machine or manual laying shall be used in the parapet area.

The upper face of the surface course shall be given a good slope outwards from the guardrail post all around the post.
 - x) Quantity shall be measured as planned length of parapet area with guardrail posts. Unit: m
- 87.1641 Laying in parapet area**
- a) Comprises laying of waterproofing/surface course in parapet area.
 - x) Quantity shall be measured as planned mass. Unit: ton
- 87.1642 Connection with guardrail posts**
- a) Comprises connection of waterproofing/surface course with guardrail posts.
 - x) Quantity shall be measured as number of connections with guardrail posts. Unit: pcs
- 87.165 Connection with water outlet**
- a) Comprises connection of waterproofing/surface course with water outlets.
 - c) Waterproofing shall be laid right up to the water outlet and with overlap if possible.

Before the deck is laid, the upper edge of the water outlet shall be protected with a steel plate or some other appropriate steel formwork which is kept well centred over the outlet. Formwork shall have a rounded form, or possibly rectangular with rounded circular corners depending on the design of the outlet pipe, and have an overlap of at least 50 mm onto the bridge deck around the water outlet.

The formwork shall be removed immediately after the deck has been laid. If necessary it can be heated with a propane burner to release it from the base. Topeka 45 or some other appropriate material shall be laid between stripped surface and water outlets with good adhesion to side edges and base so that a funnel is formed down into the water outlet.

The base shall be clean and dry when filling takes place.

Other execution that leads to the same design may be accepted, but must be submitted to the Project Owner for review and comment before the work starts.

- x) Quantity shall be measured as number of connections. Unit: pcs

87.17 Crack inducing joints and asphalt joints

- a) Comprises crack inducing joints and asphalt joints
- b-e) As in Specifications 87.12, 87.13 and 87.14 and *the special specifications*.
- x) Quantity shall be measured as length of joint per joint type and size. Unit: m

87.171 Crack inducing joints

- a) Comprises crack inducing joints filled with bitumen.

The following procedure is used for crack inducing joints:

Grooves with a width of 15-20 mm and depth of 35-40 mm shall be cut in the surface course. (The maximum joint width must be limited to 20 mm to prevent the asphalt edges breaking because of traffic loads).

All loose material shall be removed using compressed air and the track cleaned and any moisture dried off thoroughly.

Appropriate polymer-modified bitumen or ordinary rubber bitumen joint fill shall be heated in a boiler to 180-190°C and the joint filled up completely.

The surface shall then be sanded with dry sand in a quantity sufficient to prevent undesired sticking/pulling.

- x) As in Specification 87.17. Unit: m

87.172 Asphalt joints

- a) Comprises asphalt joints. All costs associated with lifting against or passage through kerbing or edge beams are included in the specification.
- b) The following materials shall be used for asphalt joints unless otherwise described in *the special specifications*:

Aggregate shall be washed and dried in grades 8/11 mm and 11/16 mm and satisfy flakiness index, Los Angeles abrasion value and milling value requirements for an ADT>5000 surface course. Other aggregate grades may be used according to agreement with the Project Owner.

Binder shall be of type polymer-modified bitumen and satisfy the requirements made of polymer-modified bitumen in Specification 87.14 for surfacing type A3-4.

Steel plates covering joint openings shall be delivered in steel type S235JRG2 or better and be galvanized in accordance with Specification 85.342.

Along the centre of the steel plate's underside, flat rolled steel t=10mm, W=10 mm, H=200mm shall be welded with a centre distance of 500mm along the entire length of the steel plate in order to centre and keep the steel plate in place in the joint space.

If an asphalt joint is to be led up diagonally to terminate at the kerbing/edge beam, the steel plate shall be bent for installation with a shape that is fitted to the recess side edge. Steel plating shall also be fitted to the slope on the top of the bridge deck.

Fully worked steel plate with welded on flat steel shall be delivered hot galvanized in accordance with Specification 85.342.

The maximum size of the joint opening shall be indicated in *the special specifications*.

The thickness and width of the steel plate shall be adapted to the joint opening as follows:

- Joint opening less than 30 mm: t=3 mm, W=200 mm (also in abutment-free solution)
- Joint opening from 30 to 80 mm: t=8 mm, W=280 mm
- Joint opening from 80 -110 mm: t=12 mm, W=300 mm
- Joint opening larger than 110 mm: As specified in *the special specifications*.

The dimensioning movement that the asphalt joint must take up shall be indicated in *the special specifications*. The same applies to min. and max. temperature at the bridge site and the movement pattern of bridges for which the asphalt joint is described. (Steel bridges have rapid temperature movements compared with concrete and timber bridges).

Supplier shall dimension the joint on the basis of the drawings and specified dimensioning movement and movement pattern. The mix shall be proportioned such that the quantity of binder is adapted to the particle distribution and results in complete filling of spaces between aggregate particles. The asphalt joint shall also be strong enough to absorb dimensioning movement within a given temperature range at the bridge site without the asphalt joint cracking or becoming too soft.

The mix and material safety data sheet and particle distribution curve and documentation of the aggregate shall be submitted to the Project Owner for comment before the work is carried out.

- c) If the joint supplier's instructions for paving differ from this description, this shall be clarified with the Project Owner before start-up.

The geometry of the asphalt joint shall be adapted to the thickness of abutting surfacing, the width of the joint opening, the joint movement and the supplier's detail engineering. The final geometry shall be specified by supplier, but shall not be less than 60 cm in width for steel plate with a width of 20 cm and 70 cm for steel plate with a width of up to 300 mm.

A vertical cut shall be sawn in the abutting surface course down to the top of the waterproofing but not so deep that the waterproofing is damaged. Surface course, adhesion-preventing agent and all loose material shall be removed and all surfaces dried well with the aid of a hot-air lance.

For joint-free transitions to abutting road, a sufficiently stable support must be established for steel plate and solid anchoring for the asphalt joint in the masses against the bridge end. This can be done by concreting a reinforced concrete plate with an opening against the bridge superstructure with the upper edge flush with the bridge superstructure or by laying a thick layer of asphalt as a foundation for the asphalt joint. It is also essential for the transition that the abutment fill is well compacted so that settlements do not occur. If there is risk of settlements in the subgrade, steel plate should not be used. Measures to achieve a satisfactory base for asphalt joints in fill shall be detailed in *the special specifications*.

It shall be checked that any bottom fill material is in place and sealing/blocking the joint opening so that mass cannot get into the joint.

A trial assembly of the steel plate shall be carried out. It shall lie absolutely flush against the base along its entire length and breadth to avoid the plate later rising into the surface course. If lack of contact is registered, deviations and unevennesses shall be levelled with appropriate mortar before further work takes place.

The joint bed shall be blast cleaned to ensure good adhesion to the binder.

Heated binder (max. 190°C) shall be applied with a steel trowel or similar in an evenly thick layer on all surfaces. It is particularly important that vertical and sloping surfaces be treated to ensure adhesion/watertightness. The steel plate shall then be centred over the joint opening with welded on flat steel down in the opening. Fresh, hot binder shall be applied and distributed over the surface.

The binder shall be heated according to supplier's instructions. The maximum temperature of the binder shall not exceed 190°C. The aggregate shall be heated to 150°C and mixed with the binder in a paddle mixer. During mixing the necessary heat must be added to keep the temperature high enough to ensure good mixing and laying quality.

Laying shall be carried out with continuous working of the mix. The joint shall be built up to approx. 10 mm below the top of abutting surfacing. The asphalt joint shall then be given time to cool (fall in temperature). Fresh aggregate shall be dried/heated in the mixer to approx. 150°C. It shall have hot binder added to it and if necessary some fine sand until a thick mix is obtained. The material shall be transported to and distributed in the joint such that a slight superelevation is obtained (approx. 5 mm). Finally the surface shall be smoothed and the asphalt joint vibrated with a plate vibrator to ensure good casting and adhesion in connections. The finished asphalt joint shall be flush with abutting surface course.

The whole operation shall be completed with an extra sealing of the joint and 10-15 cm in on abutting surfacing with heated bitumen and subsequent sanding in a quantity sufficient to prevent undesired adhesion/pulling.

- e) A check shall be made that the top of the asphalt joint is flush with the top of abutting surface course.

A straight-edge shall be used to check that the evenness class for surfacing work has been satisfied for joint and abutting surface course.

A check shall be made with water or after heavy precipitation that the joint is watertight.

- x) Quantity shall be measured as planned volume. Unit: litre

87.18 Expansion joint nosings

- a) Comprises expansion joint nosings against joint structures.
- b-c) Materials and execution shall be in accordance with Specifications 87.12, 87.13, 87.14, 87.15 and *the special specifications*. Unless otherwise indicated in *the special specifications*, the breadth of each threshold shall be 60 cm. Thickness shall be such that the top of the expansion joint nosing lies 5 mm higher than the joint structure and flush with the top of abutting surface course.

A vertical cut shall be sawn in the abutting surface course down to the top of the waterproofing, but not so deep that the waterproofing is damaged. Unless otherwise indicated in *the special specifications*, the depth of the cut shall be 50 mm. Surface course, adhesion-preventing agent and all loose material shall be removed, and tack coat applied to a dry base as indicated in Specification 87.12. Expansion joint nosing shall be laid on broken, tack-coated and cleaned surface and the upper surface compacted well with a vibroplate.

Joint nosings of Topeka and mastic asphalt shall be strewn with pre-coated chippings. The tacky surface on the top of the joint nosing shall be strewn with fine sand.

A check shall be made that the top of the expansion joint nosing lies 5 mm above the top edge of the joint structure and flush with the top of abutting surface course.

A straight-edge shall be used to check that the evenness class for surfacing work has been satisfied for expansion joint nosing and abutting surface course.

- d) Level difference between joint structure and expansion joint nosing: 5 ± 2 mm.
- x) Quantity shall be measured as planned volume. Unit: litre

87.181 Joint nosings of mastic asphalt

- a) Comprises expansion joint nosings of mastic asphalt.
- x) Quantity shall be measured as planned volume. Unit: litre

87.182 Joint nosings of Topeka, stone-filled

- a) Comprises joint nosings of stone-filled Topeka.

PmBE60 (C60BP3) or similar is used as tack coat and Topeka 4S which is filled with chippings. 8/11 stone that fulfils requirements with respect to flakiness index, Los Angeles abrasion value and aggregate crushing value as for surface course for ADT>500 or better shall be used as aggregate.

The joint nosing shall be built up such that the quantity of Topeka 4S is adapted to the particle distribution and provides complete filling of spaces between aggregate particles, but the proportion of Topeka 4S shall not be so large that the joint nosing is too soft. The mix and material safety data sheet and particle distribution curve and documentation on the aggregate shall be submitted to the Project Owner for comment before the work is carried out.

Topeka 4S shall be heated according to supplier's instructions. The maximum temperature shall not exceed 190°C. The aggregate shall be heated to 150°C. During mixing sufficient heat must be added to keep the temperature high enough to ensure good mixing and paving quality.

- x) Quantity shall be measured as planned volume. Unit: litre

87.2 Parapets

- a) Comprise the following:

- delivery and installation of all types of parapets on bridges and support structures
- protective barriers over electrified railways
- noise barriers
- transitions to safety barriers, parapet terminals and crash cushions
- earthing and signposting/labelling of protective barriers and bridge parapets over electrified railways
- barriers and protective fences to prevent public passage, climbing, playing etc. when there is a risk of falling and other undesired events in connection with bridges and support structures
- fencing in of areas that are to be closed to the public for reason of the safety of the bridge structure
- measuring and detailed engineering
- repair of damage to corrosion protection on existing parapets in connection with the installation of transitions to new bridge parapets
- concrete work in connection with grouting of base plates and casting of parapet recesses
- recesses for bridge parapets that are anchored in the structure when grouting the recesses

Steel work for the anchor plate for steel decks is covered by Specification 85.

- b) See Handbook 231 Rekkverk [Road restraint systems], Handbook 267 Standard vegrekkverk [Standard safety barriers] and Handbook 268 Standard brurekkverk [Standard bridge parapets]

General

Bridge parapets with transitions, end terminals and crash cushions shall be type approved or, in special cases, given separate approval for the project in question by the Norwegian Public Roads Administration. Parapets of prefabricated concrete elements shall be type approved, while cast in-situ concrete parapets or parapets that form an integral part of the bridge structure shall be approved as a structure if the type approval has not been given in advance for the project in question. Bridge parapets and/or anchoring that deviate from the type-approved solution shall be approved by the Norwegian Public Roads Administration.

Bridge parapets with transitions, end terminals and crash cushions shall be delivered and installed with material qualities, composition and design equivalent to a type-approved or approved solution.

Bridge parapets and protective barriers on bridges over railways shall additionally be approved by the Norwegian National Rail Administration in each individual case.

Concrete

See Specification 84.4.

Concrete shall be produced in strength class B45 with Norwegian concrete specifications SV 40. SV 30 shall be used if so indicated in *the special specifications*.

The frost resistance of the concrete shall be documented by pre-testing before concreting work begins and also during the specification. Unless otherwise indicated in *the special specifications*, a sample shall be taken for each 1000 metres of parapet or part thereof.

Frost resistance shall be at least one of the following: Swedish Standard 13 72 44, Version 3 from 1995 (the Borås method):

Maximum spalling 1.0 kg/m² and m56/m28 less than 2.0.

NS-EN 480-11 – Determining the air pore structure of hardened concrete:

Distance factor of less than 0.25 mm and specific surface of more than 25 mm²/mm³.

Grout/concrete for anchoring of posts: As in Specification 84.871. Mortar/concrete for grouting of base plates: As in Specification 84.872.

Steel

See Specification 85.1.

All steel and fasteners with the exception of fasteners for anchoring to the structure shall be hot galvanized in accordance with Specification 85.342. If powder coating is used in addition, this shall be indicated by *the special specifications*. The same applies to the colour code for powder coating. Powder coating shall be carried out in accordance with Specification 85.36.

Part of the hot galvanized massive guardrail posts which are to be anchored in the parapet recesses and part of the hot galvanized base plate which is exposed to fresh mortar during grouting shall be protected against chemical reaction and gas production as indicated in Specification 84.86.

Bolts and threadbars for anchoring to the structure shall be of corrosion-resistant stainless steel A4-80 in accordance with NS-EN-ISO 3506. Washers and nuts in anchoring shall be of the same corrosion-resistant quality or hot-dip galvanized in accordance with Specification 85.342. Unless otherwise specified in *the special specifications*, corrosion-resistant washers and nuts shall be used. To make subsequent replacement of posts simpler, stainless steel nuts shall have appropriate wax or emulsion applied to the threads before use.

Modification (cutting, punching etc.) of existing steel guard rails on abutting roads and structures shall be corrosion-protected with Maintenance System 3 in accordance with Specification 88.48.

Wood

See Specification 86.1.

Wooden posts shall be pressure-impregnated to Nordic impregnation class A.

Aluminium

See Specification 86.3.

Plastic

Plastic posts, plastic sleeves etc. shall be approved by the Norwegian Public Roads Administration in connection with approval of the parapet system.

See also *the special specifications*.

- c) See Handbook 231 Parapets, Handbook 267 Standard safety barriers and Handbook 268 Standard bridge parapets.

Detailed engineering

Detailed engineering is carried out in accordance with Handbook 185 Prosjekteringsregler for bruer [Design rules for bridges], Handbook 231 Parapets, Handbook 267 Standard safety barriers, Handbook 268 Standard bridge parapets and on the basis of measurements and drawings.

Work and workshop drawings of parapets that have not been type-approved shall be submitted to the Norwegian Directorate of Public Roads for approval, and shall be approved before fabrication begins.

Work drawings and workshop drawings of all parapets shall be submitted to the Project Owner for comment before fabrication in the workshop starts.

Work drawings shall satisfy the requirements concerning drawings in Handbook 185 Design rules for bridges and "as built" drawings shall be forwarded to the Project Owner after the work has been completed.

The strength class for parapets and special functional requirements, such as the requirement that the structure tolerate snow ploughing, shall be specified in *the special specifications*.

In measuring and preparation of work and workshop drawings, particular emphasis shall be placed on incorporating the necessary flexibility so that the cross-fall of the bridge deck and any tolerance deviations from original drawings have no consequences.

Account shall also be taken of expansion joints by placing guardrail posts with the joint/joint structure approximately midway between the posts, and by incorporating the capacity necessary to absorb the bridge's movement.

Unless otherwise indicated in *the special specifications*, the posts shall be vertical.

Concreting

Formwork

See Specification 84.2. Steel formwork shall be used, or plywood coated with plastic on surfaces facing the carriageway where there is a risk of wheels gaining purchase in irregularities and climbing. Board formwork is not permitted on this type of surface.

Prefabricated concrete elements shall be fabricated without construction joints. All corners shall be chamfered with 10-20 mm triangular skirting.

Reinforcement

As in Specification 84.3. Concreting

As in Specification 84.4. Concrete shall not be stripped of formwork before it is sufficiently solid for damage and undesired deformations not to occur. Immediately after stripping, newly concreted parapets shall be protected against desiccation by covering them in plastic foil for a minimum of 24 hours.

Steel works

As in Specifications 85.2, 85.3 and 85.4 with subordinate specifications.

Wood works

As in Specification 86.1 with subordinated specifications. Wooden materials shall not be so saturated with impregnating agent that it seeps out of the wood and soils the surroundings and users.

Aluminium works

As in Specification 86.3

Anchoring

Guardrail posts in the ground

Posts in the ground shall have an anchoring depth as for full scale testing. Standard parapets shall have a framework depth of at least 1200 mm. To ensure that requirements regarding framework depth are satisfied, the posts shall be clearly marked 1200 mm from the tip

Guardrail posts anchored in bridge

The amount of threadbar protruding above the nut shall not be less than 5 mm or more than the bolt diameter.

Fixing of guardrail posts with anchored bolt group

Adjustment of the post with wedges etc. is not permitted. Formwork for grouting must be designed so that air can escape during grouting. Pretreatment, cleaning and pre-wetting of concrete base shall be carried out as specified in Specification 88.32. Grouting shall be carried out in accordance with Specification 84.872.

Anchoring of guardrail posts in cast recesses

Only guardrail posts with a round or rectangular massive steel sections may be fixed in cast recesses.

Recesses shall be a minimum of 250 mm deep with a minimum distance between outer contour and free edge of 150 mm. Corners in recesses shall be rounded off with a radius of at least 50 mm. The light opening between guardrail post and concrete shall be at least 15 mm. The bottom of the recess shall be made conical, with drainage to the underside of the bridge from the lowest point in the bottom of the recess. Drainage pipes shall be cross-cut and arranged with systematic spouts protruding from the underside of the bridge deck.

Formwork material for making recesses shall be surface resident so that material residues are not left on the surface of the concrete. In other respects as in Specification 84.2.

Anchoring in parapet recesses shall be carried out in accordance with Specification 84.871.

The top of the grouting shall be given a gradient of 1:5 from the base of the post. The grouting shall be sealed with an appropriate elastic cement-based slurry or epoxy with at least 3 cm overlap onto abutting concrete and 10 cm up on the guardrail post.

Anchoring of guardrail posts in steel deck

Guardrail posts with a welded on base plate shall be used. Corrosion protection shall be applied after the base plate has been welded to the post.

Posts shall be fixed to a welded-on anchor plate in the bridge deck with bolts in threaded holes.

- d) Fully installed parapets shall have no disfiguring deviations in height or laterally from the theoretically correct placing measured at the level of the highest element in the parapet. Deviations in height and laterally in a straight line shall be a maximum of +/- 5 mm over a length of 5 metres. Curved parapets shall not have disfiguring deviations when viewed along the parapet. The guardrail posts shall not have larger deviations from a theoretically correct location than +/- 3 mm.

Unless otherwise indicated in *the special specifications*, tolerance requirements also apply to protective barriers and noise barriers.

For concrete works, see Specification 84. Prefabricated concrete elements shall have an even surface without fins, fissures or surface pores. In other respects, the requirements for tolerance class 1 in Specification 84 d) shall be satisfied.

Type approval and/or other special approval shall be submitted to the Project Owner.

Documentation for correct zinc thickness shall be submitted to the Project Owner.

- x) Quantity shall be measured as planned parapet length per parapet type, including supplements for vertical and horizontal curvature, expansion joints, edge details, transitions, downslope parts and adaptations. Unit: m

87.21 Detailed engineering

- a) Comprises detailed engineering of complete parapets on bridges with barriers, safety fences, transition to safety barriers and/or end terminals.
- x) The costs shall be specified as a lump sum. Unit: LS

87.22 Vehicle-proof steel parapet

- a) Comprises delivery and installation of steel vehicle-proof parapets. Also applies to urban bridge parapets.
- x) As in Specification 87.2. Unit: m

87.221 Outer steel parapet

- a) Comprises delivery and installation of external steel parapets.
- x) As in Specification 87.2. Unit: m

87.222 Intermediate steel parapets

- a) Comprises delivery and installation of steel intermediate railings.
- x) As in Specification 87.2. Unit: m

87.23 Steel top parapet

- a) Comprises delivery and installation of steel top parapets.
- x) As in Specification 87.2. Unit: m

87.24 Steel pedestrian guardrail

- a) Comprises delivery and assembly of steel pedestrian guardrail.
- x) As in Specification 87.2. Unit: m

87.25 Parapets of concrete, aluminium and timber

- a) Comprises delivery and installation of parapets of concrete, aluminium and timber.
- x) As in Specification 87.2. Unit: m

87.251 Concrete parapet composed of elements

- a) Comprises delivery and installation of concrete parapet elements.
- x) As in Specification 87.2. Unit: m

87.252 Cast in situ concrete parapets

- a) Comprises cast in situ concrete parapets.
- x) As in Specification 87.2. Unit: m

- 87.253 Aluminium parapets**
- a) Comprises delivery and installation of aluminium parapets.
 - x) As in Specification 87.2. Unit: m
- 87.254 Wooden parapets**
- a) Comprises delivery and installation of wooden parapets.
 - x) As in Specification 87.2. Unit: m
- 87.26 Barriers**
- a) Comprises delivery and installation of protective barriers over railways and noise barriers.
 - x) As in Specification 87.2. Unit: m
- 87.261 Delivery and erection of protective barriers over railways**
- a) Comprises delivery and installation of protective barriers over railways including earthing and signposting/labelling.
 - x) As in Specification 87.2. Unit: m
- 87.262 Delivery and installation of noise barriers**
- a) Comprises delivery and installation of noise barriers.
 - x) As in Specification 87.2. Unit: m
- 87.27 Parapet details**
- a) Comprises delivery and installation of special parapet details such as end terminals, crash cushions and transitions to safety barriers. Supplements for expansion joints in parapets and barriers are also included.
 - x) Costs shall be given as a lump sum. Unit: LS
- 87.271 Delivery and installation of end terminals**
- a) Comprises delivery and installation of end terminals.
 - x) Quantity shall be measured as number of end terminals. Unit: pcs
- 87.272 Delivery and installation of crash cushions**
- a) Comprises delivery and installation of crash cushions.
 - x) Quantity shall be measured as number of crash cushions. Unit: pcs
- 87.273 Delivery and installation of transitions to safety barriers**
- a) Comprises delivery and installation of transition between bridge parapet and safety barrier.
 - x) Quantity shall be measured as number of transitions. Unit: pcs
- 87.274 Expansion joints**
- a) Comprises supplement for execution of expansion joints in parapets and adaptation of expansion joints.
 - x) Quantity shall be measured as number of expansion joints. Unit: pcs
- 87.28 Safety fences**
- a) Comprises delivery and installation of safety fences outside safety barriers on culverts, around cable anchors, on walkable beam flanges etc. to protect against falling or prevent access.
 - x) As in Specification 87.2. Unit: m
- 87.3 Bridge bearings**
- a) Comprises delivery and installation of complete bearings including bearing recesses, dismantling of transport protection, presetting, grouting and concreting in position.
 - b) Bearings shall generally be engineered, fabricated and delivered in accordance with NS-EN 1337-1-9. The type and size of the bearings shall be as specified in *the special specifications*.

Bearings that are not engineered, manufactured and delivered in accordance with this standard shall be specially approved by the Norwegian Public Roads Administration in each individual case.

Any anchors shall be designed such that the bearing can be easily replaced.

All steel in bearings shall be corrosion-protected with System 1 as specified in Specification 85.3 or hot-dip galvanized as specified in Specification 85.342. Steel that cannot be protected with System 1 or hot galvanized shall be corrosion-resistant stainless steel in accordance with NS-EN 10088, no. 1.4435, 1.4436 or the equivalent. Fasteners (bolted connections, clamps etc.) shall be of corrosion resistant stainless steel in accordance with NS-EN ISO 3506, quality A4-80 or the equivalent.

To make subsequent replacement easier, stainless steel nuts shall have appropriate wax or emulsion applied to the threads before assembly.

Components of hot galvanized steel that are exposed to fresh mortar shall be protected against chemical reactions and gas production as indicated in Specification 84.86.

Grouting mortar in recesses: As in Specification 84.871. Mortar for grouting: As in Specification 84.872. See also the special works specification.

- c) The bearings shall be transported, stored and assembled at the construction site in accordance with NS-EN 1337-11 so that no damage occurs.

Pretreatment, cleaning and pre-wetting of concrete base shall be carried out as specified in Specification 88.32. Grouting shall be carried out in accordance with Specification 84.872.

The bearings shall be assembled in the correct position and with the correct pre-setting. After concreting in position/bolting the assembly/transport protection shall be removed.

See also the special works specification.

- d) The assembly tolerances for the bearings shall be adapted to the planned utilisation ratio of the deformation and load capacity of the bearings. See *the special specifications* and the supplier's specifications.
- x) Quantity shall be measured as number of bearings of each size and type. Unit: pcs

87.31 Deformation bearings (block bearings)

- a) Comprises delivery and installation of block bearings. (Deformation bearings are understood to mean block bearings of rubber reinforced with embedded steel plates) Movements are absorbed through deformation of the rubber).
- b) The bearings shall be approved and tested for use at low temperatures.
- x) Quantity shall be measured as number of bearings of each size and type. Unit: pcs

87.32 Fixed bearings

- a) Comprises delivery and installation of fixed bearings.
- x) Quantity shall be measured as number of bearings of each size and type. Unit: pcs

87.33 Free/multidirectional sliding bearings

- a) Comprises delivery and installation of free/multidirectional sliding bearings.
- x) Quantity shall be measured as number of bearings of each bearing size and type. Unit: pcs

87.34 Guided/unidirectional sliding bearings

- a) Comprises delivery and installation of guided/unidirectional plain bearings.
- x) Quantity shall be measured as number of bearings of each size and type. Unit: pcs

87.35 Roller bearings

- a) Comprises delivery and installation of roller bearings.
- x) Quantity shall be measured as number of bearings of each size and type. Unit: pcs

87.36 Cylindrical bearings

- a) Comprises delivery and installation of cylindrical bearings.
- x) Quantity shall be measured as number of bearings of each size and type. Unit: pcs

87.37 Spherical bearings

- a) Comprises delivery and installation of spherical bearings.
- x) Quantity shall be measured as number of bearings of each size and type. Unit: pcs

87.4 Joint structures

- a) Comprises detailed engineering, delivery and installation of complete joint structures.

The specification also encompasses end edges, passages through kerbing/edge beams and concrete parapets and dewatering systems under open joints.

Installation includes cleaning of recesses for joints, cleaning of construction joints, and making any adjustments necessary and concreting in position of the joint structure.

Work associated with waterproofing and wearing courses, crack inducing joints, asphalt joints and expansion joint nosings is included in Specification 87.1.

- b) For material requirements and approved joint types, see *the special specifications*.

Joint structures without documented, satisfactory experience from Norwegian or comparable conditions shall be approved by the Norwegian Public Roads Administration before use.

The special specifications shall specify whether special requirements are made with respect to low noise and accessibility for cyclists and pedestrians.

Detailed requirements regarding type of joint structure and capacity for absorbing movement shall be laid down in *the special specifications*. Dimensioning movements during the installation phase due to temperature changes and any creep or wastage shall also be indicated in *the special specifications* so that they can be taken into account by the contractor.

All steel in joint structures shall be corrosion-protected with System 1 as specified in Specification 85.3 or hot-dip galvanized as specified in Specification 85.342. Steel that cannot be protected with System 1 or hot galvanized shall be of corrosion-resistant stainless steel in accordance with NS-EN 10088, no. 1.4435, 1.4436 or the equivalent. Fasteners (bolted connections, brackets etc.) shall be of corrosion resistant stainless steel in accordance with NS-EN ISO 3506, quality A4-80 or the equivalent.

To make replacement at a later date simpler, stainless steel nuts shall have appropriate wax or emulsion applied to the threads before assembly.

Components of hot galvanized steel that are exposed to fresh mortar shall be protected against chemical reactions and gas production as indicated in Specification 84.86.

In the interests of flexibility, the contractor shall order extra joint components and rubber membrane length in excess of theoretical measures in order to allow for cutting of lengths etc. in installation that takes place in stages.

Special reinforcement that is laid in the cover zone to secure the joint structure shall be of stainless steel in accordance with Specification 84.323. Unless otherwise specified in *the special specifications*, rebars of stainless steel in accordance with NS-EN 10088, no. 1.4401 or the equivalent shall be used, and with measurements and mechanical properties in accordance with NS 3576-3.

Concrete for casting shall be in accordance with Specification 84.4, and unless otherwise indicated by *the special specifications* shall satisfy the following requirements:

- Concrete quality B45 SV-40
- Dmax = 16 mm

Grouting mortar in recesses: As in Specification 84.871. Mortar for grouting: As in Specification 84.872.

- c) **Detailed engineering**

The contractor shall check the length of joints and the opening of the joint gap in situ and detail engineer the selected joint structure before the joint structure is ordered.

The drawings and measuring at the bridge site shall form the starting point for the detailed engineering, which shall among other things ensure that the design of the joint bed, special reinforcement in the joint bed for securing the joint structure, end edges and installation are adapted to the specific joint structure that is used.

Moreover, requirements regarding waterproofing and other special requirements arising from *the special specifications* shall be taken into account.

The detailed engineering includes a review of the design basis for all bridge elements with detailed design which will have a bearing on the installation of joint structures and functioning during the operations period. The following are singled out for special mention:

- The bridge's movements in the period while joint installation is in progress and during the operations period, and its position when installation takes place.
- Deviations, horizontal and vertical curvature in the superstructure will influence movements in all parts of the expansion joint.
- Recesses for joint beds, size of joint opening and reinforcement design
- Recesses in kerbing, edge beam and concrete parapet
- Guardrail posts and securing of parapets
- Orientation of bearings in relation to horizontal plane
- Stretching of cables over the joint opening
- Expansion joint nosing and waterproofing/wearing course

Detailed engineering shall be submitted to the Project Owner for comment before final ordering of a joint structure.

Concreting

If a need is discovered for measures over and above the work necessary to grout a joint structure in position, the Project Owner shall be notified and further work shall be agreed separately. There may, for example, be a need to rectify damage or to establish a larger joint gap to absorb movements.

Pretreatment and cleaning of joint bed

Recesses for joint bed shall be thoroughly sandblasted to remove all surface skin and reveal the aggregate on the surface. The base shall be cleaned of all loose material and dust and pre-wet so that it is water-saturated but with a dry surface immediately before concreting.

Formwork

See Specification 84.2.

Joint openings shall be supported with formwork so that the initial position of the joint structure at the temperature at the time of installation is as described in *the special specifications*.

Formwork in the joint opening shall not obstruct movements in the structure and enable constraint forces to develop. Single-sided formwork shall therefore be used which does not obstruct thermal dilations in the bridge.

The supplier of the joint structure and the contractor shall work together on a formwork solution. This shall be submitted to the Project Owner for review and comment before work commences.

All formwork shall be removed as soon as possible after concreting.

Reinforcement

See Specification 84.3.

The contractor shall draw up a final bending schedule on the basis of measurement of real geometry and the supplier's reinforcement requirements. The bending list shall be submitted to the Project Owner for review and comments. It must be possible to cut lengths and bend the reinforcement in situ if a need arises for special adaptations on the building site, or there must be a short delivery time for supplementary, ready cut and bent reinforcement from supplier.

Special reinforcement in stainless steel quality for anchoring of the joint structure shall have a minimum of 25 mm of cover after concreting.

Delivery and installation of joint structure

The supplier's instructions shall be followed.

The joint structure with end edges and covers shall be installed in position so that no constraint forces of any kind arise in the joint structure or bridge during the operation period as a result of the bridge's movements. The installation shall moreover be such that there are no projecting parts that may come into conflict with traffic or winter maintenance as a result of a change in position when the superstructure moves.

Rubber sealing shall be laid continuously through the entire joint structure and up into any end edges.

Where there are passages through the edge beam, the joint structure shall be given a projection of about 100 mm from the side of the bridge where there is a slope and water runoff to prevent water access and discolouring of the underlying concrete.

The joint structure shall be installed such that it lies parallel with and 5 mm below the upper edge of adjacent joint nosing and wearing course.

The joint elements shall be loosened as soon as possible after casting of the joint bed so that no constraint forces develop in connection with thermal dilations in the bridge.

Once the concrete is sufficiently cured, the bolts shall be tightened, any protruding ends cut off flush with the respective joint element and bolt holes in joint elements filled with spackle in accordance with the description of the joint fill supplier.

The joint structure shall be watertight along its entire length after installation including passages through kerbing, edge beams and concrete parapets.

For joint structures that are designed to be open, i.e. for full water passage, flexible skirts, drains and water outlets shall be set up under the joint so that water can be led away from the bridge in a controlled manner. Allowance must be made for inspection, cleaning and replacement of parts or the whole system. For steel in direct contact with chlorine-containing run-off water, corrosion-resistant stainless steel is required according to NS-EN 10088, no. 1.4435, 1.4436 or the equivalent. Fasteners (bolted connections, clamps etc.) shall be of corrosion resistant stainless steel in accordance with NS-EN ISO 3506, quality A4-80 or the equivalent. To make replacement at a later date simpler, stainless steel nuts shall have appropriate wax or emulsion applied to the threads before assembly.

Cleaning up

Joint openings, bearing recesses and underlying terrain shall be completely free of sand, debris, chip-pings etc. when the work is completed.

See also *the special specifications*.

The specified construction tolerances of the joints shall be adapted to the planned utilisation ratio for the movement capacity of the joints. See *the special specifications* and the supplier's specifications.

Level difference between joint structure and joint nosing and wearing course: 5 ± 2 mm.

The contractor undertakes to carry out his own inspection of the joint set-up and reinforcement before concreting, and to notify the Project Owner before concreting so that the Project Owner's representative can be present at concreting work.

Before traffic is allowed on to a grouted joint structure, it shall be verified that the concrete strength is at least B30. This is done through theoretical calculation of strength as a function of temperature in the curing phase. If this is prescribed in *the special specifications*, the concrete strength shall be documented by means of at least four samples which are cast at the same time as the grouting and placed by the bridge until testing takes place. Two of the samples shall be subjected to pressure before traffic is allowed on the bridge and shall then have a pressure strength equivalent to B25 for both individual samples. If this is not achieved, the date for opening the bridge to traffic must be postponed, and if necessary the two remaining samples subjected to pressure.

Waterproofing shall be checked in all parts of the joint structure by means of long-term flushing with water or in connection with heavy precipitation. This also applies to pedestrian pavement joints and end edges.

After completion of installation and stripping, bearing recesses and joint openings shall be closely inspected to ensure that all surplus material has been removed.

A check shall be made that the upper edge of the joint nosing lies 5 mm above the upper edge of the joint structure and flush with the top of the abutting wearing course.

A straight-edge shall be used to check that the evenness class for paving works has been satisfied for the joint structure, joint nosing and abutting wearing course corrected for the level difference between joint structure and joint nosing.

- x) Quantity shall be measured as length of joint per joint type and size. Unit: m

87.41 Finger joints

- a) Comprises engineering, delivery and installation of finger joints.
- b) *The special specifications* shall indicate whether the joint is to be of the watertight type with a rubber membrane, open with an underlying water-runoff system, or both.
- x) Quantity shall be measured as length of joint per joint type and size. Unit: m

87.42 Multi-element joints

- a) Comprises delivery and installation of multi-element joints, i.e. steel or aluminium lamellae with rubber membrane between the lamellae.
- b) The rubber profiles shall be watertight and not come into contact with traffic. For large movements, the lamellae are arranged on crossbars with bearings at each end. These are oriented and can slide in the direction of movement of the bridge.
- x) Quantity shall be measured as length of joint per joint type and size. Unit: m

87.43 Other joint types

- a) Comprises engineering, delivery and installation of other joint types.
- x) Quantity shall be measured as length of joint per joint type and size. Unit: m

87.44 Supplement, noise-reducing measures

- a) Comprises supplements for noise-reducing measures.
- b-e) See *the special specifications*.
- x) Quantity shall be measured as length of joint per joint type and joint size with special design to reduce noise. Unit: m

87.45 Supplement, gearing to pedestrian and cycle traffic

- a) Comprises supplement for gearing to pedestrian and cycle traffic.
- b-e) See *the special specifications*.
- x) Quantity shall be measured as length of joint per joint type and joint size specially designed for pedestrian and cycle traffic. Unit: m

87.46 End edges and passages

- a) Comprises all supplements for edges and ducts that are not calculated into other specifications.
- x) Quantity shall be measured as number of end edges and ducts. Unit: pcs

87.461 End edges in kerbing/edge beam

- a) Comprises end edge of joint structure in kerbing/edge beam. Cover over joint opening with anchoring is included.
- x) Quantity shall be measured as number of end edges. Unit: pcs

87.462 End edges in concrete parapets

- a) Comprises end edge of joint structure in concrete parapets. Cover over joint opening with anchoring is included.
- x) Quantity shall be measured as number of end edges. Unit: pcs

87.463 Passages through kerbing/edge beam

- a) Comprises ducts through joint structure in kerbing/edge beam.
- x) Quantity shall be measured as number of ducts. Unit: pcs

87.47 Water runoff system

- a) Comprises delivery and installation of underlying water runoff system in addition to primary waterproofing. Measurement and detailed engineering form part of the specification.
- b-c) Detailed engineering shall be submitted to the Project Owner for review and comments before fabrication and installation. Installation shall ensure an adequate slope. Underlying terrain shall be secured against erosion.

See also the *special works specification*.

- x) Quantity shall be measured as length of joint structure with water runoff system. Unit: m

87.5 Water drainage and other pipe systems

- a) Comprises delivery and assembly of water drainage and other pipe systems.

Recesses for ducts etc. are included in Specification 84.275. Pipe used as formwork is included in Specification 84.255.

Ducts for electric cables and delivery and installation of heating cables for frost protection of pipes are included in Specification 87.6.

- b-c) Materials that do not corrode or degrade as a result of UV light, temperature etc. shall be used.

In saline environments, corrosion-resistant stainless steel in accordance with NS-EN 10088, no. 1.4435, 1.4436 or the equivalent shall be used. Fasteners (bolted connections, brackets etc.) shall be of corrosion resistant stainless steel in accordance with NS-EN ISO 3506, quality A4-80 or the equivalent. To make replacement at a later date simpler, stainless steel nuts shall have appropriate wax or emulsion applied to the threads before assembly.

Components of hot-dip galvanized steel that are exposed to fresh mortar shall be protected against chemical reactions and gas production as indicated in Specification 84.86.

Grating and associated adjustable frames for gratings shall be in accordance with the requirements in NS-EN 124. Grating slots shall be at an angle of 45° to the driving direction. Frames shall be of spheroidal graphite iron. The minimum internal diameter and free projecting length from the underside of the bridge deck shall be 150 mm.

If sand traps are used, it must be easy to dismantle gratings in order to empty/suction off sediments from the carriageway unless otherwise described in *the special specifications*.

The concrete cover over the reinforcement around the pipe conduit shall be in accordance with the cover for the structure.

See also *the special specifications*.

- e) After installation, the watertightness of the assembled pipe systems shall be checked by filling them with water. There shall be no water leakage.
- x) Costs shall be given as a lump sum. Unit: LS

87.51 Simple water drains

- a) Comprises delivery and installation of simple water gullies to drain surface water from the upper surface of the bridge deck, closed spaces inside box girders etc. Welded in gratings to lead runoff water from the upper surface of the bridge deck are included.
- x) Quantity shall be measured as number of outlet pipes. Unit: pcs

87.52 Adjustable drain

- a) Comprises delivery and installation of adjustable drains with gratings in adjustable frame.
- b-c) The diameter of the pipe shall be adjusted to the frame of the grating.

Grating with frame shall be installed in accordance with the supplier's instructions. See also *the special specifications*.

- x) Quantity shall be measured as number of drains. Unit: pcs

87.53 Sand traps

- a) Comprises delivery and installation of sand traps.
- b-c) Sand traps shall be installed in accordance with the supplier's instructions and shall be simple to replace.

See also *the special specifications*.

- x) Quantity shall be measured as number of sand traps. Unit: pcs

87.54 Drainage system

- a) Comprises delivery and installation of all materials for runoff drainage systems from drains including connection to drainage pipes in the ground for collecting runoff water. The specification also includes detailed engineering, assembly and installation details, bends, joints, transitions, expansion joints at abutments etc.

The drainage system in the ground is included in Principal Specification 4.

- b-c) Detailed engineering shall be submitted to the Project Owner for review before start-up.

The pipe system shall be replaceable. For securing to the structure, conduits, insulation against frost and other information, see *the special specifications*.

- x) Quantity shall be measured as installed pipe length. Unit: m

87.55 Other pipe systems

- a) Comprises delivery and installation of other pipe systems such as water and waste water pipes, long-distance heating pipes etc. The specification also includes detailed engineering, assembling and installation details, bends, joints, transitions, expansion joints at abutments etc.

- b-c) Detailed engineering shall be submitted to the Project Owner for review before start-up.

The pipe system shall be replaceable. For sand traps, transitions to downpipe systems, frost insulation, heating cables and other information, see *the special specifications*.

- x) Quantity shall be measured as installed pipe length. Unit: m

87.6 Electrical installations

- a) Comprises detailed engineering, delivery, installation and termination of complete electrical installations on bridges and at ferry terminals.

Delivery and installation of cables, cable racks, ducts etc. wiring in the bridge are also included in the specification.

- b-e) All electrical devices shall be new and CE-marked with a declaration of compliance with current rules and regulations. Corrosion-resistant stainless steel shall be in accordance with NS-EN 10088, no. 1.4435, 1.4436 or the equivalent. Fasteners (bolted connections, clamps etc.) shall be of corrosion-resistant stainless steel in accordance with NS-EN ISO 3506, quality A480 or the equivalent. To make replacement at a later date simpler, stainless steel nuts shall have appropriate wax or emulsion applied to the threads before assembly.

Partially embedded steel shall be of stainless steel (acid-proof quality).

Cable bridges, supports etc. shall be of material that is non-corrodible in the environment in question. Internally in bridges and in substations, hot-dip galvanized steel in accordance with Specification 85.342 or the equivalent may be used. Surfaces with external exposure shall be protected with UV resistant plastic, corrosion-resistant stainless steel, saline-resistant aluminium or similar.

Components of hot-dip galvanized steel that are exposed to fresh mortar shall be protected against chemical reactions and gas production as indicated in Specification 84.86.

Grouting mortar in recesses: As in Specification 84.871. Mortar for grouting: As in Specification 84.872.

Pre-treatment, cleaning and pre-wetting of concrete base shall be carried out as specified in Specification 88.32. Grouting shall be carried out in accordance with Specification 84.872.

Installation work shall be carried out such that no corrosion occurs at connection points as a result of the use of different types of materials and corrosion protection.

The enclosure rating in accordance with NEK 400 (Norwegian Electrical Committee standard: Electrical low-voltage installations) shall be at least:

- Indoors in closed spaces: IP 54
- Out of doors in dry atmospheric environment: IP 66
- Near water and in a damp environment: IP 68.

The contractor shall assure himself of and verify that all electrical material, components and devices are appropriate to their purpose in accordance with exposure stress/load code which shall be indicated in *the special specifications* in the tender documents and are mutually compatible in the combinations used.

Engineering and execution of cathodic protection systems shall be as specified in NS-EN 12696 and with the standard and the tendering documents forming the basis for engineering.

Any interface with suppliers of electrical and mechanical equipment shall be described by the contractor or be indicated in *the special specifications*.

The starting point for the detailed engineering shall be a CWR analysis pursuant to NEK 401 (complexity, scope of work, risk). In the detailed engineering, special emphasis shall be placed on ensuring that ducts and installations are concealed as far as possible and do not spoil the appearance of the structure, while not constituting an obstacle to future inspections and maintenance.

The detailed engineering shall be submitted to the Project Owner for review and comments well before materials are ordered and installation work begins.

All installation shall be carried out according to FEL (Norwegian regulation relating to low-voltage electrical systems) or FEF (Norwegian regulation relating to Electrical Supply System with guidelines). It is specified in particular that ducts that are to be embedded shall be installed by authorised personnel (see FKE – Regulation relating to qualification of electrical and electronics specialists).

Electrical power cables shall be laid separately from telecommunications cables and signal cables and in such a way that the electrical power cables do not cause disturbances.

When the installation work is completed, the contractor shall prepare final documentation and a declaration of compliance with FEL, NEK 400 (Norwegian Electrotechnical Norm) and FEF.

Final documentation shall also be prepared as specified in Handbook 185 Design rules for bridges. See also *the special specifications*.

- x) Costs shall be given as a lump sum. Unit: LS

87.61 Electrical installations

- a) Comprises all materials, work and equipment for a complete electrical installation for electrical and mechanical equipment at bridge/ferry terminals.

On bridges, the specification comprises delivery and installation of ducts for pulling cables in bridge decks before casting work, heating cables at water outlets etc.

For ferry terminals the specification comprises complete electroinstallation as described in Handbook 141 Fergeleier -2 [Ferry terminals-2], Handbook 175 Standard ferjekaibrer [Standard ferry quay bridges], Handbook 175-2 Elektrohydrauliske styresystemer [Electro-hydraulic control systems] and Handbook 181 Standard ferjekaier [Standard ferry quays].

- x) Costs shall be given as a lump sum. Unit: LS

87.62 Lighting

- a-c) Comprises delivery and installation of complete lighting with connection at the distribution panel. All costs that are not covered by Specification 87.61 are included in the specification.

For ferry terminals the specification comprises complete lighting as described in Handbook 141 Ferry terminals-2, Handbook 175 Standard ferry quay bridges and Handbook 181 Standard ferry quays.

- x) Costs shall be given as a lump sum. Unit: LS

87.621 Road lighting

- a) Comprises delivery and installation of complete road lighting including poles with supports and fittings, and any ducts, cables, terminations, distribution boards etc. on bridges and at ferry terminals.

- x) Costs shall be given as a lump sum. Unit: LS

87.622 Marking and warning lights

- a) Comprises delivery and installation of marking and warning lights designed to warn traffic on roads, in the air and on water on bridges and at ferry terminals.

- x) Costs shall be given as a lump sum. Unit: LS

87.623 Decorative lighting

- a) Comprises delivery and installation of complete decorative lighting on bridges and at ferry terminals.

- x) Costs shall be given as a lump sum. Unit: LS

- 87.624 Internal lighting**
- a) Comprises delivery and installation of complete internal lighting inside box girders, hollow columns etc. Light switches shall be installed by all inspection hatches/doors.
 - x) Costs shall be given as a lump sum. Unit: LS
- 87.625 Other lighting**
- a) Comprises delivery and installation of other lighting according to special specifications.
 - x) Costs shall be given as a lump sum. Unit: LS
- 87.63 Special electrical equipment for ferry terminals**
- a-c) Comprises delivery and installation of special electrical devices for ferry terminals as described in Handbook 141 Ferry terminals-2, Handbook 175 Standard ferry quay bridges and Handbook 181 Standard ferry quays. All costs that are not covered by Specification 87.61 are included in the specification.
 - x) Costs shall be given as a lump sum. Unit: LS
- 87.631 Electrical control gear for main and emergency power**
- a) Comprises delivery and installation of complete electrical control gear.
 - x) Quantity shall be measured as number of control gears. Unit: pcs
- 87.632 Electrical material and equipment in electrical and hydraulic plant room**
- a) Comprises delivery and installation of electrical material and equipment such as cables, delivery point boxes, switch gear, sockets, luminaires etc. in the electrical and hydraulic plant room.
 - x) Costs shall be given as a lump sum. Unit: LS
- 87.633 Cable drum for emergency power**
- a) Comprises delivery and installation of cable drum for emergency power.
 - x) Quantity shall be measured as number of cable drums. Unit: pcs
- 87.64 Power supply**
- a) Comprises delivery and installation of transformers, rectifiers, generators, solar panels, windmills, accumulators etc. with enclosure, support, cabling, ducts etc. All costs that are not calculated into Specification 87.61 are included in the specification.
 - x) Costs shall be given as a lump sum. Unit: LS
- 87.65 Control and monitoring systems**
- a) Comprises delivery and installation of control and monitoring systems on bridges and at ferry terminals for ferry quay bridges and movable bridges, traffic flow, cathodic protection systems etc. and instrumentation and monitoring systems for reading weather conditions, stresses, function, state estimation, alarm systems etc. Data loggers, modems, computers, PLS, software, mobile telephones, instrumentation, sensors, enclosure, support, cabling, ducts etc. also form part of the specification. All costs that are not calculated into Specification 87.61 are included in the specification.
 - x) Costs shall be given as a lump sum. Unit: LS
- 87.651 Control systems for ferry quay bridges**
- a) Comprises delivery and installation of control systems for ferry quay bridges as described in Handbook 141 Ferry terminals-2, Handbook 175 Standard ferry quay bridges, Handbook 175-2 Electrohydraulic control systems and Handbook 181 Standard ferry quays.
 - x) Costs shall be given as a lump sum. Unit: LS
- 87.6511 Radio control**
- a) Comprises delivery and installation of radio control of the type indicated in *the special specifications*.
 - x) Quantity shall be measured as number of transmitters/receivers. Unit: pcs
- 87.6512 Signal lights for ferry quay bridge**
- a) Comprises delivery and installation of signal lights.
 - x) Quantity shall be measured as number of signal boxes. Unit: pcs
- 87.6513 Automatic control of ferry quay bridge (docking)**
- a) Comprises delivery and installation of automatic control system for raising and lowering ferry quay bridge.
 - x) Costs shall be given as a lump sum. Unit: LS

- 87.652 Control systems for movable bridges**
- a) Comprises delivery and installation of control systems for movable bridges.
 - x) Costs shall be given as a lump sum. Unit: LS
- 87.653 Control and monitoring system for traffic flow**
- a) Comprises delivery and installation of traffic control and monitoring systems for traffic flow on movable bridges, bridges that are closed in strong wind, system for automatic closing if a ship runs into them etc.
 - x) Costs shall be given as a lump sum. Unit: LS
- 87.654 Control and monitoring system for cathodic protection**
- a) Comprises delivery and installation of control and monitoring system for cathodic protection.
 - x) Costs shall be given as a lump sum. Unit: LS
- 87.655 Instrumentation and surveillance**
- a) Comprises delivery and installation of instrumentation and surveillance.
 - x) Costs shall be given as a lump sum. Unit: LS
- 87.6551 Instrumentation and monitoring of weather conditions**
- a) Comprises delivery and installation of system for instrumentation and monitoring of weather conditions.
 - x) Costs shall be given as a lump sum. Unit: LS
- 87.6552 Instrumentation and monitoring of stresses**
- a) Comprises delivery and installation of system for instrumentation and monitoring of stresses.
 - x) Costs shall be given as a lump sum. Unit: LS
- 87.6553 Instrumentation and monitoring of function**
- a) Comprises delivery and installation of system for instrumentation and monitoring of function.
 - x) Costs shall be given as a lump sum. Unit: LS
- 87.6554 Instrumentation and monitoring of condition**
- a) Comprises delivery and installation of system for instrumentation and monitoring of condition and state estimation.
 - x) Costs shall be given as a lump sum. Unit: LS
- 87.656 Alarm systems**
- a) Comprises delivery and installation of alarm systems.
 - x) Costs shall be given as a lump sum. Unit: LS
- 87.66 Anodes for cathodic protection**
- a) Comprises delivery and installation of sacrificial anodes and anodes with impressed current for cathodic protection and connection to steel and power supply.
 - x) Costs shall be given as a lump sum. Unit: LS
- 87.67 Surge protection**
- a) Comprises delivery and installation of lightning conductor, earthing and other surge protection.
 - x) Costs shall be given as a lump sum. Unit: LS
- 87.7 Mechanical equipment**
- a) Comprises detailed engineering, delivery and installation of mechanical equipment. For ferry quay bridges, the specification includes complete mechanical equipment as described in Handbook 141 Ferry terminals-2, Handbook 175 Standard ferry quay bridges and Handbook 181 Standard ferry quays. All costs for electrical work that is not covered by Specification 87.61 are included in the specification.
 - b-e) All mechanical equipment shall satisfy the Machinery Directive and be delivered with CE marking, documentation and directions for use in Norwegian.
- For ferry quay bridges, see Handbook 141 Ferry terminals-2, Handbook 175 Standard ferry quay bridges and Handbook 181 Standard ferry quays.
- The detailed engineering shall be submitted to the Project Owner for review and comments well before materials are ordered and installation work begins. Final documentation shall be prepared as prescribed in the Machinery Directive and in Handbook 185 Design rules for bridges.

For steel work, see Specification 85 with sub-specifications.

Stainless steel shall be of acid-proof quality in accordance with NS-EN 10088, no. 1.4435, 1.4436 or the equivalent. Supports (bolted connections, clamps etc.) shall be of corrosion-resistant stainless steel in accordance with NS-EN ISO 3506, quality A480 or the equivalent. To make replacement at a later date simpler, stainless steel nuts shall have appropriate wax or emulsion applied to the threads before assembly. Partially embedded steel shall be stainless steel (acid-proof quality).

Cable bridges, supports etc. shall be of material that is non-corrodible in the environment in question. Internally in bridges and in technical rooms, hot-dip galvanized steel in accordance with Specification 85.342 or the equivalent may be used. Surfaces with external exposure shall be protected with UV resistant plastic, corrosion-resistant stainless steel, saline-resistant aluminium or the equivalent.

Components of hot-dip galvanized steel that are exposed to fresh mortar shall be protected against chemical reactions and gas production as indicated in Specification 84.86.

Grouting mortar in recesses: As in Specification 84.871. Mortar for grouting: As in Specification 84.872.

Pre-treatment, cleaning and pre-wetting of concrete surfaces shall be carried out as specified in Specification 88.32. Grouting shall be carried out in accordance with Specification 84.872.

Installation work shall be carried out such that no corrosion occurs at connection points as a result of the use of different types of materials and corrosion protection.

Unless otherwise indicated in *the special specifications*, all other steel shall be protected against corrosion by hot-dip galvanizing in accordance with Specification 85.342. Steel components that are too large to be hot-dipped shall be protected against corrosion with System 1 in accordance with Specification 85.3.

All anchoring in the bridge structure shall be planned before building and prepared during the building process. On concrete structures, anchoring shall be provided by grouted bolt groups or by adhesive anchors.

In steel structures, holes shall be drilled in the workshop before corrosion protection is applied. Corrosion protection shall not be damaged by assembly work.

See also *the special specifications*.

- x) Costs shall be given as a lump sum. Unit: LS

87.71 Hydraulic equipment

- a) Comprises delivery and installation of hydraulic equipment for movable bridges, lifting/hoist systems for ferry quay bridges and other hydraulic equipment. Lift towers for ferry quay bridges are included in Specification 85.

- x) Costs shall be given as a lump sum. Unit: LS

87.711 Hydraulic generators

- a) Comprises delivery and installation of hydraulic generators.

- x) Quantity shall be measured as number of generators. Unit: pcs

87.712 Hydraulic cylinders

- a) Comprises delivery and installation of hydraulic cylinders for opening or lifting and closing of movable bridges, ferry quay bridges, locking systems etc.

- x) Quantity shall be measured as number of cylinders. Unit: pcs

87.713 Hydraulic pipes and hoses

- a) Consists of delivery and installation of hydraulic pipes and hoses as specified in *the special specifications*.

- x) Costs shall be given as a lump sum. Unit: LS

87.72 Pumps

- a) Comprises detailed engineering, delivery and installation of pumps.

- x) Quantity shall be measured as number of pumps. Unit: pcs

87.73 Dehumidifying systems

- a) Comprises detailed engineering, delivery and installation of dehumidifying systems.

- x) Quantity shall be measured as number of dehumidifying systems. Unit: pcs

87.74 Emergency power generators

- a) Comprises detailed engineering, delivery and installation of emergency power generators.

- x) Quantity shall be measured as number of emergency power generators. Unit: pcs

87.75 Permanent movable access equipment

- a) Comprises delivery and installation of movable access equipment such as lifts, internal inspection trolleys and painting trolleys etc. including suspension/brackets, lift cables, weights, rail system fixed in the load-bearing structure, propulsion machinery with control system etc.

Access to trolleys is included in Specification 87.83.

- c) Access equipment shall be designed and installed so that rules from government authorities are complied with.

Trolleys shall be equipped with an emergency brake. Lifts shall be equipped with an emergency telephone with direct contact to a manned operations centre. See also the special works specification.

- x) Costs shall be given as a lump sum. Unit: LS

87.751 Lifts

- a) Comprises delivery and installation of lifts inside bridge pylon etc.

- x) Quantity shall be measured as number of lifts. Unit: pcs

87.752 Inspection trolleys

- a) Comprises delivery and installation of inspection trolleys inside box girders etc.

- x) Costs shall be given as a lump sum. Unit: LS

87.753 Painting trolleys

- a) Comprises delivery and assembly of painting trolleys etc.

- x) Costs shall be given as a lump sum. Unit: LS

87.76 Barriers

- a) Comprises delivery and installation of barriers.

- x) Quantity shall be measured as number of barriers. Unit: pcs

87.8 Other equipment

- a) Comprises detailed engineering, delivery and installation of other equipment.

- b-e) For ferry quay bridges, see Handbook 141 Ferry terminals-2, Handbook 175 Standard ferry quay bridges and Handbook 181 Standard ferry quays.

The detailed engineering shall be submitted to the Project Owner for review and comments well before materials are ordered and installation work begins. Final documentation shall be prepared as specified in Handbook 185 Design rules for bridges.

For steel works, see Specification 85 with underlying specifications.

Corrosion-resistant stainless steel shall be in accordance with NS-EN 10088, no. 1.4435, 1.4436 or the equivalent. Supports (bolted connections, clamps etc.) shall be of corrosion-resistant stainless steel in accordance with NS-EN ISO 3506, quality A480 or the equivalent. To make replacement at a later date simpler, stainless steel nuts shall have appropriate wax or emulsion applied to the threads before assembly. Partially embedded steel shall be of stainless steel (acid proof quality).

Supports etc. shall be of material that is non-corrodible in the environment in question. Internally in bridges and in technical rooms, hot-dip galvanized steel in accordance with Specification 85.342 or the equivalent may be used. Surfaces with external exposure shall be protected with UV resistant plastic, corrosion-resistant stainless steel, saline-resistant aluminium or the equivalent.

Components of hot-dip galvanized steel that are exposed to fresh mortar shall be protected against chemical reactions and gas production as indicated in Specification 84.86.

Grouting mortar in recesses: As in Specification 84 871. Mortar for grouting: As in Specification 84 872.

Pre-treatment, cleaning and pre-wetting of concrete surfaces shall be carried out as specified in Specification 88.32. Grouting shall be carried out in accordance with Specification 84.872.

Installation work shall be carried out such that no corrosion occurs at connection points as a result of the use of different types of materials and corrosion protection.

Unless otherwise indicated in *the special specifications*, all other steel shall be protected against corrosion by hot-dip galvanizing in accordance with Specification 85.342. Steel components that are too large to be hot-dipped shall be protected against corrosion with System 1 in accordance with Specification 85.3.

All anchoring in the bridge structure shall be planned before building and prepared during the building process. On concrete structures, anchoring shall be provided by grouted bolt groups or with adhesive anchors.

In steel structures, holes shall be drilled in the workshop before corrosion protection. Corrosion protection shall not be damaged through assembly work.

See also the applicable rules and regulations and *the special specifications*.

- x) Costs shall be given as a lump sum. Unit: LS

87.81 Vibration dampers and fendering

- a-c) Comprises delivery and installation of vibration dampers on bridges, fendering on bridges and supplementary quays and fenders behind ferry quay bridges.

Fendering for ferry quays and fenders for ferry quay bridges shall be completed as described in Handbook 141 Ferry terminals 2, Handbook 175 Standard ferry quay bridges, Handbook 181 Standard ferry quays and *the special specifications*.

- x) Costs shall be given as a lump sum. Unit: LS

87.811 Vibration dampers

- a) Comprises delivery and installation of vibration dampers.
- x) Quantity shall be measured as number of vibration dampers. Unit: pcs

87.812 Fendering for bridges and ferry quays

- a) Comprises fendering as impact protection against vehicle and shipping traffic on bridges and ferry quays.
- x) Costs shall be given as a lump sum. Unit: LS

87.813 Fenders for ferry quay bridges

- a) Comprises fenders for ferry quay bridges.
- x) Quantity shall be measured as number of fenders. Unit: pcs

87.82 Reference points

- a) Comprises delivery and installation/grouting in position of bolts for measuring joint movements, leveling and position determination (reading of coordinates). Comprises precise measurement of reference point immediately after establishment and reporting.
- b) Grouting of bolts shall be carried out with corrosion-resistant grouting material/mortar, and the bolts shall be of acid proof stainless steel.
- c) Reference markers for level control and position determination (reading of coordinates) shall be related to established benchmarks external to the bridge.

All installed bolts shall be marked with a unique reference number which is used in reporting.

- x) Quantity shall be measured as number of measurement points. Unit: pcs

87.821 Bolts for measuring joint movements

- a) Comprises bolts for measuring joint movements.
- c) A bolt is installed on each side of the joint opening.
- x) Quantity shall be measured as number of measurement points; each measurement point has two bolts. Unit: pcs

87.822 Bolts for level control

- a) Comprises bolts for level control.
- x) Quantity shall be measured as number of measurement points. Unit: pcs

87.823 Bolts for position determination

- a) Comprises bolts for position determination corresponding to polygon points.
- x) Quantity shall be measured as number of measurement points. Unit: pcs

87.83 Installed access equipment

- a) Comprises delivery and installation of access equipment such as stairs, ladders, footways, doors, hatches, securing wires on main cables etc.

Permanent access equipment such as lifts, inspection trolleys and painting trolleys form part of Specification 87.75.

- c) Access equipment shall be designed and installed so that rules from government authorities are complied with. Ladders shall be equipped with rest platforms and caging.

All installed access equipment that may be used by unauthorised persons shall be closed with a locking device and lock system as indicated in *the special specifications*.

See also *the special specifications*.

- x) Costs shall be given as a lump sum. Unit: LS
- 87.831 Delivery and installation of stairs**
 - a) Comprises delivery and installation of stairs.
 - x) Quantity shall be measured as number of stairs. Unit: pcs
- 87.832 Delivery and installation of ladders**
 - a) Comprises delivery and installation of ladders.
 - x) Quantity shall be measured as number of ladders. Unit: pcs
- 87.833 Delivery and installation of hatches**
 - a) Comprises delivery and installation of hatches.
 - x) Quantity shall be measured as number of hatches. Unit: pcs
- 87.834 Delivery and installation of doors**
 - a) Comprises delivery and installation of doors.
 - x) Quantity shall be measured as number of doors. Unit: pcs
- 87.835 Delivery and installation of securing wires**
 - a) Comprises delivery and installation of wires to secure load-bearing cables etc.
 - x) Quantity shall be measured as length of securing wire. Unit: m
- 87.836 Delivery and installation of footways**
 - a) Comprises delivery and installation of footways.
 - x) Quantity shall be measured as length of footways. Enhet: m
- 87.84 Equipment and service buildings**
 - a-c) Comprises delivery and installation of electrical and hydraulic plant rooms, operation and service buildings and other buildings associated with bridges and ferry terminals.

Buildings for ferry terminals shall be complete as described in Handbook 141 Ferry terminals-2, Handbook 175 Standard ferry quay bridges and Handbook 181 Standard ferry quays.
 - x) Costs shall be given as a lump sum. Unit: LS
- 87.841 Generator house and equipment building**
 - a) Comprises delivery and construction of electrical power plant and other equipment buildings.
 - x) Costs shall be given as a lump sum. Unit: LS
- 87.842 Operation and service buildings**
 - a) Comprises delivery and erection of operation and service buildings.
 - b-c) The service building shall be adapted for disabled users (stairs, door openings, toilets etc.) See also *the special specifications*.
 - x) Costs shall be given as a lump sum. Unit: LS
- 87.85 Equipment for buildings**
 - a) Comprises delivery and installation of equipment for buildings for bridges and ferry terminals as indicated in *the special specifications*.
 - b-c) Equipment for buildings for ferry terminals shall be complete as described in Handbook 141 Ferry terminals-2, Handbook 175 Standard ferry quay bridges and Handbook 181 Standard ferry quays.
 - x) Costs shall be given as a lump sum. Unit: LS
- 87.851 Fittings**
 - a) Comprises delivery and installation of fittings.
 - x) Costs shall be given as a lump sum. Unit: LS
- 87.852 Sanitary equipment**
 - a) Comprises delivery and installation of sanitary equipment.

- x) Costs shall be given as a lump sum. Unit: LS
- 87.853 Connection to water supply**
 - a) Comprises delivery and installation of water supply outlets for washing and cleaning and for ferries in ferry terminals.
 - x) Costs shall be given as a lump sum. Unit: LS
- 87.854 Water drainage**
 - a) Comprises delivery and installation of drains for leading away water after washing and cleaning.
 - x) Quantity shall be measured as number of drains/waste water outlets. Unit: pcs
- 87.855 Oil separator**
 - a) Comprises delivery and installation of oil separators in drainage systems for leading away water after washing and cleaning.
 - x) Quantity shall be measured as number of oil separators. Unit: pcs
- 87.86 Decoration**
 - a) Comprises delivery and installation of decoration on bridges.
 - x) Costs shall be given as a lump sum. Unit: LS
- 87.87 Special equipment for ferry terminals**
 - a) Comprises delivery and installation of special equipment for ferry terminals as described in Handbook 141 Ferry terminals-2, Handbook 175 Standard ferry quay bridges and Handbook 181 Standard ferry quays.
 - b-e) See *the special specifications*.
 - x) Costs shall be given as a lump sum. Unit: LS
- 87.871 Mooring equipment (pullers, bollards)**
 - a) Comprises delivery and installation of mooring equipment (pullers).
 - x) Quantity shall be measured as number of pullers. Unit: pcs
- 87.872 Safety equipment for quays**
 - a) Comprises delivery and installation of safety equipment such as rescue ladder, lifebuoy, protective edgings etc.
 - x) Costs shall be given as a lump sum. Unit: LS
- 87.8721 Rescue ladders**
 - a) Comprises delivery and installation of rescue ladder.
 - x) Quantity shall be measured as number of rescue ladders. Unit: pcs
- 87.8722 Life buoys**
 - a) Comprises delivery and installation of life buoys.
 - x) Quantity shall be measured as number of life buoys. Unit: pcs
- 87.8723 Protective edging**
 - a) Comprises delivery and installation of edging along quay to protect vehicles from driving over the edge.
 - x) Quantity shall be measured as length of quay edging. Unit: m
- 87.88 Signs**
 - a) Comprises delivery and erection of signs.
 - x) Quantity shall be measured as number of signs. Unit: pcs

88 INSPECTION, OPERATIONS AND MAINTENANCE

- a) Comprises inspection, operation and maintenance of bridges and ferry terminals.

The specification comprises all costs of performing the work so that requirements for the flow of traffic are satisfied and waste collection and disposal are carried out in accordance with Handbook 211 Avfallshåndtering [Waste management]

- b-c) Materials and execution shall be in accordance with government regulations and current guidelines for the management, operation and maintenance of bridges.

All water that is used shall be freshwater free of harmful substances for bridge structures or paint. The work shall be performed in such a way that the spread of fish diseases and unwanted species does not occur. Freshwater used for work on bridges over or by watercourses shall come from sources where the quality can be documented as satisfactory or from watercourses that are affected by the work. All equipment shall be disinfected before start-up if there is a possibility that it might not be clean.

- x) Costs shall be given as a lump sum. Unit: LS

88.1 Inspections

- a) Comprises planning and carrying out inspections of bridges and ferry terminals including measurements, material investigations, taking and recording instrument readings, reporting etc.

- c) Inspections, measurements and material investigations shall be carried out as specified in Handbook 147 Forvaltning, drift og vedlikehold av bruer [Management, operation and maintenance of bridges], Handbook 136 Inspeksjonshåndbok for bruer [Inspection handbook for bridges] and *the special specifications*.

Marking spray-paint, waterproof felt pens etc. shall be used as little as possible and only in a discrete colour. Boreholes, places where the surface has been broken up and damage that occurs in connection with inspections, shall be repaired.

- x) Costs shall be given as a lump sum. Unit: LS

88.11 Rigging, access equipment and scaffolding

- a) Comprises all costs for rigging, access equipment, scaffolding, access techniques etc. such as contracted services, transport, rigging, all costs for the use of scaffolding, bridge lifts, boats, rafts, machinery and equipment etc. which are necessary to perform the specified inspection work when such costs are not included in other specifications.

- c) Scaffolding shall be designed and carried out in accordance with current Norwegian Standards for the materials that are used, and according to regulations from the Norwegian Labour Inspection Authority.

Bridge lifts shall be certified/approved for passenger transport.

Inadvertent damage to the bridge structures or adjacent areas shall be repaired without cost to the Project Owner. When access equipment is used, bridges or parts of bridges shall not be subjected to greater loads than those permitted. If there are plans to subject the bridge structure to special loads beyond those the structure was designed for, these shall be submitted to the Project Owner for approval.

See also *the special specifications*.

- x) Costs shall be given as a lump sum. Unit: LS

88.12 Final inspection/claims inspection

- a) Comprises final inspection/claims inspection of bridges in the case of new facilities, maintenance work and renovations (modifying, reinforcement).

- c) To be carried out as specified for final inspections/claims inspections in Handbook 136 Inspection handbook for bridges and *the special specifications*.

- x) Quantity shall be measured as bridge area, i.e. total bridge width × total bridge length for bridges and diameter × length for pipes. Unit: m²

88.13 General supervision and temporary securing

- a) Comprises general supervision of bridges and temporary securing if needed.

- b-c) General supervision shall be conducted in such a way that the overall thoroughness is at least as specified for individual inspections in Handbook 136 Inspection handbook for bridges and *the special specifications*.

General supervision shall ensure that unexpected events or damage are discovered in time, so that consequential damage that may affect safety or passability can be avoided. In the case of serious damage or events, the Project Owner/party responsible for bridge maintenance shall be notified immediately.

A check shall be made that the performance requirements are satisfied in accordance with the functionality agreement and to see that the measures carried out have been satisfactory. If the functionality requirements have not been satisfied, measures shall be implemented.

Temporary securing shall be carried out in accordance with current procedures.

- x) Quantity shall be measured as bridge area, i.e. total bridge width × total bridge length. Unit: m²

88.14 Basic inspection

- a) Comprises basic inspection of bridges.
- c) To be carried out as specified for basic inspections in Handbook 136 Inspection handbook for bridges and *the special specifications*.
- x) Quantity shall be measured as bridge area, i.e. total bridge width × total bridge length and diameter × length for pipes. Unit: m²

88.15 General inspection

- a) Comprises general inspections of bridges.
- c) To be performed as specified for general inspections in Handbook 136 Inspection handbook for bridges and *the special specifications*.
- x) Quantity shall be measured as bridge area, i.e. total bridge width × total bridge length and diameter × length for pipes. Unit: m²

88.151 General inspection above water

- a) Comprises general inspections of bridges over water.
- c) To be performed as specified for general inspections in Handbook 136 Inspection handbook for bridges and *the special specifications*.
- x) Quantity shall be measured as bridge area, i.e. total bridge width × total bridge length and diameter × length for pipes. Unit: m²

88.152 General inspection of cables

- a) Comprises general inspection of load-bearing cables and hangers with fasteners. (It is recommended that general inspection of all suspension bridge elements and adjacent joint structures and support be performed at the same time.)

In such case this must be appear in *the special specifications*.
- c) To be carried out as specified for the general inspection and general inspection of cables in Handbook 136 Inspection handbook for bridges and *the special specifications*.
- x) Quantity shall be measured as suspended bridge area, i.e. total bridge deck × total suspended bridge length. Unit: m²

88.153 General inspection under water

- a) Comprises general inspection of structural components under water.

Removal of remaining formwork and fouling under water must be specifically described and if relevant included in Specification 88.235.
- c) To be carried out as specified for general inspection under water in Handbook 136 Inspection handbook for bridges and *the special specifications*.
- x) Quantity shall be measured as area of inspected foundation surface under water. Unit: m²

88.16 Special inspection

- a) Comprises special inspection of bridges.
- c) To be carried out as specified for special inspection in Handbook 136 Inspection handbook for bridges and *the special specifications*.
- x) Quantity shall be measured as inspected bridge area, i.e. total bridge width × inspected bridge length for bridges and diameter × length for pipes or as specified in *the special specifications*. Unit: m²

88.17 Measuring/material investigations

- a) Comprises measuring and material investigations together with reporting.

When measuring/material investigations involve an intervention in the structure, the specification includes repair using suitable materials and methods.

- b-c) To be carried out in accordance with specifications in Handbook 136 Inspection handbook for bridges and *the special specifications*. The contractor shall have a sound knowledge of the possibilities and limitations of the method in question and of interpreting results, if relevant.

Sampling that entails drilling, chiselling or similar shall be carried out in such a way that the least possible damage is done to the structure. Special care shall be shown when taking samples from load-bearing structural components and the method, extent and location shall be assessed in advance by bridge engineers. Extensively used steel sections and similar, as well as critical parts of load-bearing sections, for example tension reinforcement and longitudinal reinforcement in non-tensioned reinforced beams, shall not be damaged by sample-taking.

Drilling in concrete shall be carried out as specified in Specification 88.326. Drillholes, breakage etc. shall be repaired immediately after the samples have been taken with a suitable material and method as specified in Specifications 88.32, 88.326 and 88.327.

Results and an evaluation of the results shall be reported.

- x) Costs shall be given as a lump sum. Unit: LS

88.171 Measuring

- a) Comprises measuring of bridges.
- c) See *the special specifications*.
- x) Unless otherwise stated in *the special specifications*, costs shall be given as a lump sum. Unit: LS

88.1711 Levelling

- a) Comprises levelling on bridges.
- x) As in Specification 88.171. Unit: LS

88.1712 Horizontal distances/displacement

- a) Comprises measuring horizontal distances/displacements on bridges.
- x) As in Specification 88.171. Unit: LS

88.1713 Surface course thickness

- a) Comprises recording the surface course thickness of bridge decks.
- x) Quantity shall be measured as the number of thickness measurements. Unit: No.

88.1714 Rutting

- a) Comprises rutting measurements on bridge decks.
- x) Quantity shall be measured as number of measured cross-sections. Unit: No.

88.1715 Evenness

- a) Comprises measuring surface course evenness on bridges.
- x) Quantity shall be measured as measured surface. Unit: m²

88.1716 Sag

- a) Comprises measurement of relative sag of suspension cables.
- x) As in Specification 88.171. Unit: LS

88.1717 Registration of bridges

- a) Comprises registration of bridges to verify or supplement the drawings, structural data in BRUTUS etc.
- x) As in Specification 88.171. Unit: LS

88.1718 Measurement of clearance heights

- a) Comprises measurement of clearance heights over roads and sailing heights for bridges over seawater.
- x) As in Specification 88.171. Unit: LS

88.172 Material investigations - concrete

- a) Comprises sampling, backfilling of boreholes and places where the surface has been broken up, analyses, reporting etc. in connection with material investigations of concrete and reinforced concrete.
- b-e) See Handbook 015 Feltundersøkelser [Field investigations].
- x) Costs shall be given as a lump sum. Unit: LS

- 88.1721 Locating reinforcement/concrete cover**
- a) Comprises measurement of concrete cover and locating the reinforcement with a cover meter.
 - x) Quantity shall be measured as number of measurements per 1 m² cover measurements. Unit: No.
- 88.1722 Carbonation**
- a) Comprises measurement of carbonation depths in concrete structures.
 - x) Quantity shall be measured as the number of tests. Unit: No.
- 88.1723 Chloride content**
- a) Comprises measuring the chloride content of cured concrete.
 - x) Quantity shall be measured as number of profiles with the specified number of depth intervals. Unit: No.
- 88.1724 Corrosion investigations**
- a) Comprises investigation of corrosion by measuring the electrochemical corrosion potential (ECP) of the reinforcement and the associated resistance values, and evaluation/interpretation of results.
 - x) Quantity shall be measured as measured surface with the specified grid. Unit: m²
- 88.1725 Strength determination**
- a) Comprises determining the strength of concrete drill cores.
 - x) Quantity shall be measured as the number of tests where each test consists of two compressed cores. Unit: No.
- 88.1726 Structural analysis**
- a) Comprises polished section and/or thin sections of drilled concrete cores.
 - x) Quantity shall be measured as number of grindings of each type. Unit: No.
- 88.1727 Tension cable inspection**
- a) Comprises inspection of tension cables.
 - x) Costs shall be given as a lump sum. Unit: LS
- 88.1728 Breaking up surfaces to determine the extent of corrosion**
- a) Comprises breaking up surfaces, registration of the condition of the exposed reinforcement and repairing the surface where it has been broken up.
 - x) Quantity shall be measured as number of places the surface has been broken up. Unit: No.
- 88.173 Material investigations - steel**
- a) Comprises material investigations of steel.
 - c) The investigations shall be carried out in accordance with current standards and *the special specifications*.
 - x) Costs shall be given as a lump sum. Unit: LS
- 88.1731 Check of moment of force for screws**
- a) Comprises capacity check of screws in friction connections.
 - x) As in Specification 88.173. Unit: LS
- 88.1732 Nail and screw inspection**
- a) Comprises visual inspection of nails and screws.
 - x) As in Specification 88.173. Unit: LS
- 88.1733 Weld inspection**
- a) Comprises visual weld inspection of steel.
 - x) As in Specification 88.173. Unit: LS
- 88.1734 X-ray inspection**
- a) Comprises X-ray inspection of steel components.
 - x) As in Specification 88.173. Unit: LS
- 88.1735 Ultrasound inspection**
- a) Comprises ultrasound inspection of steel components.
 - x) As in Specification 88.173. Unit: LS

- 88.1736 Magnetic particle inspection**
- a) Comprises magnetic particle inspection of steel structures.
 - x) As in Specification 88.173. Unit: LS
- 88.1737 Fibre optics**
- a) Comprises fibre optics inspection of steel.
 - x) As in Specification 88.173. Unit: LS
- 88.1738 Material thickness measurements using ultrasound**
- a) Comprises ultrasound measurement of steel thickness.
 - x) As in Specification 88.173. Unit: LS
- 88.174 Material investigations – wood and stone**
- a) Comprises material investigations of wood and stone.
 - c) The investigations shall be performed in accordance with current standards and *the special specifications*
 - x) Costs shall be given as a lump sum. Unit: LS
- 88.1741 Moisture inspection of wood**
- a) Comprises moisture inspection of wood.
 - x) As in Specification 88.174. Unit: LS
- 88.1742 Inspection for fungal growth/wood rot**
- a) Comprises inspection of wood for fungal growth/rot.
 - x) As in Specification 88.174. Unit: LS
- 88.1743 Compressive strength**
- a) Comprises extraction of samples by core drilling and measurement of the compressive strength of wood or rock.
 - x) Quantity shall be measured as number of pressure tests. Unit: No.
- 88.175 Inspection of surface treatment**
- a) Comprises inspection of surface treatment.
 - c) The investigation shall be carried out in accordance with sampling standards provided in relevant specifications for applying surface treatments. See Specification 85.3, Handbook 015 Field investigations and *the special specifications*.
 - x) Unless otherwise stated in *the special specifications*, the quantity shall be given as the number of measurements. (One measurement may be the average value of several individual measurements.) Unit: No.
- 88.1751 Dry film thickness**
- a) Comprises measurement of the dry film thickness of surface treatment.
 - x) As in Specification 88.175. Unit: No.
- 88.1752 Adhesion measurement**
- a) Comprises measurement of the adhesion of the surface treatment to the base.
 - x) As in Specification 88.175. Unit: No.
- 88.1753 Penetration depth**
- a) Comprises measurement of the penetration depth of impregnation.
 - x) As in Specification 88.175. Unit: No.
- 88.1754 Chemical analyses**
- a) Comprises chemical analyses of the surface treatment.
 - x) As in Specification 88.175. Unit: No.
- 88.18 Instrumented monitoring**
- a) Comprises instrumented monitoring of bridges. The specification includes individual readings of local instrumentation, emptying of data logs manually or by means of modems, processing and presentation of the instrumentation results and reporting.
 - c) Instrumented monitoring shall be performed in accordance with *the special specifications*.
 - x) Costs shall be given as a lump sum. Unit: LS

- 88.2 Operation and groundworks**
- a) Comprises operation and earthworks.
 - x) Costs shall be given as a lump sum. Unit: LS
- 88.21 Rigging and access equipment**
- a-x) As in Specification 88.31. Unit: LS
- 88.22 Cleaning**
- a) Comprises cleaning of bridges and ferry terminals when this is not carried out as part of the general cleaning of the road network, as well as collection and dumping of waste.
 - b-c) Flushing is carried out using clean water. Where hosing alone is not enough, deposits shall be removed by sweeping and scraping or, if necessary, chipping, but in a manner that does not damage the bridge.
- On bridges and ferry terminals that are exposed to salt, cleaning shall be carried out using high-pressure hosing with water (100-150 bar) to remove as much salt as possible.
- Hosing shall be carried out with a water quantity and pressure as well as a distance from the structure that ensure that no damage is caused by the work. This applies to surface treatment and wooden components etc. Furthermore, the work shall be carried out in such a way that underlying components are not soiled.
- When cleaning parapets on bridges over railways with current-carrying lines, the precautionary measures and restrictions necessary shall be clarified with the railway company.
- After cleaning, all vegetation, sand and gravel on the structure, in joints, on ledges along and on edge beams, around the attachment points of guardrail posts etc. shall be removed.
- x) Quantity shall be measured as area cleaned. Unit: m²
- 88.221 Cleaning of the load-bearing system**
- a) Comprises hosing and cleaning of the load-bearing system.
 - c) It is especially important in the case of steel structures to clean components where wet gravel may accumulate (horizontal H-beams, flanges, stiffeners etc.) It shall be ensured that drain holes are open.
 - x) Quantity shall be measured as linear metres of bridge. Unit: m
- 88.222 Cleaning of kerbing, edge beams and parapets**
- a) Comprises hosing and cleaning of kerbing, edge beams and parapets.
 - c) If large quantities of sand and gravel should accumulate along the kerbing, suction equipment shall be used to collect up loose materials.
 - x) Quantity shall be measured as linear metres of bridge. Unit: m
- 88.223 Cleaning of bearings/bearing ledges**
- a) Comprises hosing and cleaning of bearings/bearing ledges.
 - c) Cleaning shall be carried out so that bearings/bearing ledges are completely free of sand, gravel, soil etc.
 - x) Quantity shall be measured as the number of bearing ledges including bearing. Unit: No.
- 88.224 Cleaning of joints/joint structures**
- a) Comprises hosing and cleaning of joints/joint structures.
 - c) Joint structures shall be cleaned with suitable equipment and methods that do not damage any waterproofing such as rubber profiles, membranes etc. An inspection shall be carried out to ensure that formwork material such as expanded polystyrene (EPS) and wood is removed from joint openings.
- Any removal of remaining formwork material is included in Specification 88.233.
- x) Quantity shall be measured as number of joints/joint structures. Unit: No.
- 88.225 Cleaning of water outlets/drainage systems**
- a) Comprises cleaning of water outlets/drainage systems.
 - c) Water outlets/drainage systems shall be cleaned by hosing, and if necessary scraping and rodding. The method must be adapted to the type of outlet or drainage system so that it is not damaged.
- Where a drainage system has become blocked, the specification comprises dismantling, cleaning and reassembly.
- x) Quantity shall be measured as linear metres of bridge. Unit: m

- 88.226 Cleaning of sand traps**
- a) Comprises cleaning of sand traps.
 - c) Cleaning/emptying of sand traps shall be done by sludge extraction.
 - x) Quantity shall be measured as number of cleaned sand traps. Unit: No.
- 88.23 Clearing/cleaning up**
- a) Comprises clearing/cleaning up above and below water on bridges and ferry terminals. Removal of vegetation, underbrush and trees, waste, loose objects and other items that have accumulated/are stored under, by, on and in bridges, stripping and removal of remaining formwork, superfluous materials and elements that are not in use as well as collection and depositing of waste are included in the specification.

Clearing/cleaning up is assumed to be carried out above or below water in relation to the water-table as defined in Specification 81.
 - c) The work shall be carried out carefully so that the structure is not damaged.
 - x) Costs shall be given as a lump sum. Unit: LS
- 88.231 Clearing/cleaning of water outlets**
- a) Comprises manual and mechanical cleaning of water outlets of branches, twigs, drift timber, trees and other objects that restrict or block outlets. This applies above and below water.
 - x) As in Specification 88.23. Unit: LS
- 88.232 Clearing/cleaning of ground above water**
- a) Comprises clearing/cleaning of ground above water.
 - x) As in Specification 88.23. Unit: LS
- 88.233 Clearing/cleaning on bridges and ferry terminals above water**
- a) Comprises clearing/cleaning on bridges and ferry terminals above water.
 - x) As in Specification 88.23. Unit: LS
- 88.234 Clearing/cleaning of ground below water**
- a) Comprises clearing/cleaning of ground below water.
 - x) As in Specification 88.23. Unit: LS
- 88.235 Clearing/cleaning on bridges and ferry terminals below water**
- a) Comprises removal of fouling and remaining formwork on foundations below water on bridges and ferry terminals.
 - b-e) See *the special specifications*.
 - x) As in Specification 88.23. Unit: LS
- 88.24 Expenses for operation of bridges and ferry terminals**
- a) Comprises wages and other expenses for operators, all expenses for electricity, water supply, waste-water system, sanitation, communications, service buildings (waiting room, toilets, shelters, ticket booths and operator rooms) etc. for the operation of bridges and ferry terminals.
 - x) Costs shall be given as a lump sum. Unit: LS
- 88.25 Inspection/service of electrical equipment and machinery**
- a) Comprises inspection/service and function testing of electrical equipment and machinery on bridges and ferry terminals.
 - b-e) See *the special specifications*.
 - x) The cost shall be given as a lump sum. Unit: LS
- 88.251 Inspection/service, electrical equipment**
- a) Comprises inspection/service and function testing of electrical equipment on bridges and ferry terminals.
 - b-e) See *the special specifications*.
 - x) As in Specification 88.25. Unit: LS
- 88.252 Inspection/service, machinery**
- a) Comprises inspection/service and function testing of machinery on bridges and ferry terminals.
 - x) As in Specification 88.25. Unit: LS

88.253 Performance testing, bridges and ferry terminals

- a) Comprises complete function testing with test runs on movable bridges and ferry terminals, inspection of installations on negative supports and storing in the bridge tip, locking bolts, weighted, adjustment of counterweights etc.]
- c) Function testing shall be carried out in accordance with *the special specifications*.
- x) As in Specification 88.25. Unit: LS

88.26 Earthworks

- a) Comprises earthworks above and below water for bridges and ferry terminals.

Earthworks are assumed to be carried out above or below water depending on where the work is located in relation to the water-table as specified in Specification 81.
- c) As in Specification 81, Handbook 016 Geoteknikk for veibygging [Geotechnics for road construction] and *the special specifications*.

The special specifications shall specify what limitations there are to the works due to consideration for the stability and safety of surrounding structures.
- x) Costs shall be given as a lump sum. Unit: LS

88.261 Rigging

- a-c) Comprises all costs related to putting the relevant equipment in operational condition on the site. (Excavation equipment, lorries, frontloaders etc.) Also comprises de-rigging and removal of equipment and temporary installations when the work is completed and other rigging costs that are not included in other specifications.
- x) Costs shall be given as a lump sum. Unit: LS

88.262 Excavation works above water

- a) Comprises excavation of soils and rock above water in connection with replacement of materials, removal of landslip material, levelling etc. Also covers delivery of material, loading, transport and dumping of soils at specified dumps.
- b-c) As in Specification 81.1 og *the special specifications*.
- x) As in Specification 81.1. Unit: m³

88.263 Excavation work below water

- a) Comprises excavation of uncompacted material and rock below water. Also covers scaling work and levelling as well as loading, transport and dumping of soils to specified dumps.
- b-c) As in Specification 81.3.
- x) As in Specification 81.3. Unit: m³

88.264 Placement of uncompacted soils above water

- a) Comprises delivery and placing of soils above water in connection with replacement of material, filling in of landslip areas etc. Also covers compaction and levelling.

The work is considered to be carried out above water if the fill volume is above the water-table or in a dry work location.
- b-c) The new fill materials shall be self-draining materials without susceptibility to frost. When backfilling slopes, cones and against foundations, erosion-proof materials shall be used, if no special erosion protection is to be laid out.

See also Specification 81.6 and *the special specifications*.
- x) Quantity shall be measured as planned placed volume. Unit: m³

88.265 Placement of low density materials

- a) Comprises delivery and placing of light fill materials (light clinker (expanded clay), fragmented aerated concrete, expanded polystyrene etc.) and delivery and placing of a load distribution layer over the light materials.
- b-c) See Specification 24.7, sub-specifications and *the special specifications*.
- x) Quantity shall be measured as completed placed volume. Unit: m³

88.266 Placement of uncompacted soils below water

- a) Comprises delivery and placing of soils below water in connection with replacement of materials, filling in/backfilling against and possibly under scoured foundations and abutments etc. Also covers compaction and levelling.

The work is considered to be carried out below water if the fill volume is in or below the water-table and the work location is not expected to be dry.

- b-c) Erosion-proof materials shall be used if no special erosion protection is to be laid out. See also *the special specifications*.

The filling work must be directed and controlled by divers or similar to achieve accurate positioning, slope inclination, levelling and height level check.

See also Specification 81.7 and *the special specifications*.

- x) Quantity shall be measured as planned placed volume. Unit: m³

88.267 Erosion protection

- a) Comprises placing materials for erosion protection and pitching above and below water.
- b) Requirements for rock diameter and content of fines that provide filtering effects are specified in *the special specifications*.

Erosion-protection shall be carried out with blasted rock, gabions or other relevant methods in accordance with *the special specifications*.

- c) See *the special specifications* for requirements for the thickness of erosion protection, extension from foundation edges etc.

The special specifications shall state whether the works shall be carried out below or above water.

- x) Quantity shall be measured as planned placed volume. Unit: m³

88.268 Frost protection

- a) Comprises delivery and placing of materials for frost protection.
- b-c) As in Specification 52.3 and *the special specifications*.
- x) Quantity shall be measured as planned placed volume. Unit: m³

88.3 Concrete works

- a) Comprises maintenance of reinforced concrete in bridges and ferry terminals.
- b-e) See Specification 84 Concrete, Norwegian standards related to concrete and concrete design, including NS 3473 and standards referred to in it and *the special specifications*.
- x) Costs shall be given as a lump sum. Unit: LS

88.31 Rigging, scaffolding and shielding

- a) Comprises transport, temporary storage, rigging, construction, maintenance, dismantling, derigging and overheads for all types of access equipment, lifts, bridge lifts, access and work scaffolding, shielding and cover etc. Other costs shall be included in the unit prices for work that is to be carried out and general rigging in Principal Specification 1.
- c) All works shall be executed in a satisfactory manner in compliance with current Norwegian Standards for the materials that are used, and according to the rules and regulations of the Norwegian Labour Inspection Authority.

If there are plans to subject the structure to greater loads than it has been designed for, this shall be documented with calculations that shall be submitted to the Project Owner.

Scaffolding shall be built in and shielded/covered so that spill, splashes and materials falling from the work operations that are being carried out cannot damage or soil structural elements or the environment. Any soiling shall be removed and damage repaired so that the quality is at least the same as it was before soiling/damage.

Scaffolding shall be mounted on the structure in such a way that no damage is done. This also applies to surface treatment of concrete and corrosion protection coating on steel.

Access shall be designed so that the distance to the structure is optimal for the work that is to be performed.

The contractor shall provide drawings that show the design and mounting of the scaffolding. Any damaged and/or untreated areas after anchoring and mounting shall be repaired with products that yield a quality after repair that at least corresponds to existing concrete, surface treatment of concrete and corrosion protection coating on steel.

- x) Costs shall be given as a lump sum. Unit: LS

88.311 Rigging, scaffolding, and shielding for works above water

- a) Comprises rigging, scaffolding, and shielding for work above water.
- x) Costs shall be given as a lump sum. Unit: LS

88.312 Rigging, scaffolding, and shielding for works below water

- a) Comprises rigging, scaffolding, and shielding for work below water.
- x) Costs shall be given as a lump sum. Unit: LS

88.32 Mechanical repairs

- a) Comprises maintenance of concrete.

Unless otherwise stated in *the special specifications*, the specification comprises the following work operations:

- Inspection
- Reference field
- Removal of concrete
- Reinforcement works
- Pre-treatment
- Formwork
- Cleaning and pre-wetting
- Hand grouting/spray grouting/pouring
- Finishing treatment (curing measures)

If *the special specifications* specify hand grouting, corrosion protection of reinforcement and adhesive layer is included in the specification. Cleaning of the structure and ground as well as collection, transport and depositing of used abrasives, removed concrete etc., are included in the specification.

Supplementary collection requirements for work above water and watercourses, are included in *the special specifications*. Repair of fissures and cracks is included in Specification 88.34.

- b) See Specification 84.3, Specification 84.4 and the Norwegian Concrete Association Publication no. 7, Guidelines for sprayed concrete (Norwegian text).

The contractor shall document that the materials chosen satisfy the specified requirements.

The materials shall be transported, handled and stored in such a way that the quality of the finished product is not impaired. They shall be stored and marked so that different product types and grades cannot be confused or mixed together.

All materials that are used in a repair shall be mutually compatible. Materials from the same supplier shall preferably be used to ensure this. If the contractor wished to carry out repairs with materials from different suppliers, documentation that the materials are compatible shall be submitted to the Project Owner for comment.

Special material requirements for electro-chemical methods

Should the mechanical repairs be carried out in connection with re-alkalizing/chloride extraction or installation of cathodic protection, the repair materials must not have properties that will significantly reduce or impair the effect of these methods. At the same time, the strength of the repair materials and other important properties for load-bearing and durability shall not be less than that used as a basis when designing the structure/structural element.

All water that is used for cleaning, chiselling, pre-wetting etc. shall be freshwater that does not contain substances harmful to fresh or cured reinforced concrete.

Compressed air shall be oil-free.

Reinforcement

Reinforcement shall be in accordance with Specification 84.3, and unless otherwise stated in *the special specifications*, of grade B500NC. If stainless reinforcement is to be used, the reinforcement quality shall unless otherwise stated in *the special specifications* be stainless steel rebars in accordance with NS-EN 10088, No. 1.4401 or similar with measurements and mechanical properties in accordance with NS 3576-3.

Unless otherwise stated in *the special specifications*, new reinforcement replacing damaged reinforcement shall have the same diameter, form and casing as the original.

Repair system using hand grouting

Corrosion protection of reinforcement shall be cement-based and alkali-resistant.

In environments that are exposed to chloride, corrosion protection shall have documented properties with respect to resistance to chloride penetration.

Adhesive layer

The adhesive layer shall satisfy requirements for an adhesive layer for load-bearing repairs in accordance with NS-EN 1504-4. An adhesive layer shall be used that provides full structural integration between repairs and the concrete base. When pull-off is carried out, breaks shall occur in the base or repair concrete.

Hand grouting shall satisfy the following requirements:

Table 88.32-1		
Property	Test method	Requirement
Compressive strength	NS-EN 196-1	35-55 MPa
Flexural strength	NS-EN 196-1	>5 MPa
E modulus	NS 3676	20-30 GPa
Water vapour permeability	NT Build 369	>0.5 × 10 ⁻¹² kg/msPa
Thermal expansion	TP BC-PCC	0.7-1.5 × 10 ⁻⁵ per °C
Frost resistance	SS137244	Good
pH of pore water	SINTEF KS 70133 or equivalent method	>12.5
Chloride diffusion	One of the methods NT Build 443, NT Build 355 or SINTEF MB 71116	Equal to or lower diffusion coefficient than reference concrete group B in NS 3099
Shrinkage	DIN 52450	<0.5 ‰
Swelling	DIN 52450	Shall be less than measured shrinkage

Repairs using sprayed grout

Sprayed grout shall satisfy the following requirements:

Table 88.32-2		
Property	Test method	Requirement
Compressive strength	NS-EN 196-1	45-80 MPa
Flexural strength	NS-EN 196-1	>6 MPa
E modulus	NS 3676	20-35 GPa
Water vapour permeability	NT Build 369	>0.1 × 10 ⁻¹² kg/msPa
Thermal expansion	TP BC-PCC	0.7-1.5 × 10 ⁻⁵ per °C
Frost resistance	SS137244	Good
pH of pore water	SINTEF KS 70133 or equivalent method	>12.5
Chloride diffusion	One of the methods NT Build 443, NT Build 355 or SINTEF MB 71116	Equal to or lower diffusion coefficient than reference concrete group B in NS 3099

Setting accelerators may not be used.

Concrete for casting

Concrete for casting shall be in accordance with Specification 84.4 and, unless otherwise stated in *the special specifications*, of concrete grade B45 SV-40. D_{max} is chosen on the basis of geometry, reinforcement density and obstacles to the casting, and shall be specified in *the special specifications*. If rapid curing is necessary for traffic flow reasons, this shall be stated in *the special specifications*.

Curing compound as in Specification 84.541.

Other material requirements shall be specified in *the special specifications*.

- c) See Specification 84.4 and Norwegian Concrete Association Publication No. 7: Guidelines for sprayed concrete.

All work shall be carried out in accordance with the specifications and the supplier's technical data sheet. Where there are discrepancies between the specifications and the data sheets, the Project Owner shall be informed and choices shall be made in consultation with the supplier.

Repair works shall be executed with methods and equipment in a way that permits good integration of the various sub-operations.

Work shall not be carried out at temperatures below +5°C.

Unless otherwise stated in *the special specifications*, all visible flaws, stone accumulations and spalling shall be repaired. Furthermore, all delaminations (hollow sound areas) and flaws such as embedded wood etc. shall be repaired.

If stated in *the special specifications*, all nails, band steel and other pieces of steel, plastic reinforcement spacers etc. shall be removed and cut out honeycomb shall be grouted. (This is usually necessary when electro-chemical methods are used or in subsequent surface treatment of concrete.)

When electro-chemical methods are used, consideration must be given to whether materials or repair materials have been used previously (for example curing compound, epoxy grout, water-repellent impregnations, surface treatment with epoxy etc.) which might prevent the passage of an electrical current to such an extent that the method would not produce satisfactory results. Measures shall be specified in *the special specifications*.

Inspection

Unless otherwise stated in *the special specifications*, inspections shall be carried out as close-up visual inspections supplemented with checks of hollow sound areas on all concrete surfaces that are to be maintained. If larger surfaces are to be sand-blasted, or treated with water-jetting, inspection shall be carried out afterwards, as this has been empirically shown to expose more damage/defects.

All defects shall be marked on the structure to limit water-jetting of flaws.

If damage is discovered that may affect the load-bearing capacity, the Project Owner shall be immediately notified.

Reference fields

Purpose of reference fields:

- Verify that the works will be carried out with satisfactory workmanship.
- Check that the work processes of the quality control plan provide satisfactory results or whether they must be changed.
- Detect unforeseen factors that will imply a need for new work procedures or a change in work procedures.
- Used for calibrating, for example, water-jetting equipment for selective cutting etc.
- Act as an overall reference for satisfactory execution after various work operations. The reference fields must be accessible so that they can be used throughout the work period.

In general, a reference field shall be established for all critical or repetitive work procedures before start of work on a larger scale. Reference fields shall be approved by the Project Owner before further work can commence.

It shall be documented on the reference field that execution requirements and inspection requirements are met. The location and size of the reference field shall be specified in *the special specifications*.

Removal of concrete

The safety of the structure

With the safety of the structure in mind, restrictions on the removal of concrete and the intended sequence of cutting and grouting/spray grouting/filling and necessary concrete strength before cutting can continue shall be specified in *the special specifications* and shall be followed exactly. These restrictions shall take precedence over all other cutting criteria.

If, during the work, large/deep defects that exceed the limits placed on cutting and/or severely corroded reinforcement are found, the Project Owner's representative shall be notified immediately.

Shaping of cut flaws

The edges of the remaining concrete must be shaped so that good casting is assured. In the case of spray grouting, the edges shall form an angle of about 45 degrees with the concrete surface.

Use of an angle grinder is acceptable if this is done to give a sharp transition between cut and uncut surfaces for reasons of aesthetics. Cuts shall then be a maximum of 10 mm deep. Other use of angle grinders is prohibited.

Reinforcement where the circumference of the cross-section is exposed more than 50% shall be exposed entirely. Reinforcement shall be sufficiently exposed to allow for its recasting. After exposure, the free distance between the reinforcement steel and the concrete base layer shall be a minimum of 20 mm.

Method

Unless otherwise stated in *the special specifications* mechanical cutting with handheld equipment (manual chiselling) or water-jetting shall be used.

If mini-blasting is acceptable, this shall be stated in *the special specifications*.

If selective water-jetting is to be performed with a water-jetting robot, this shall be stated in *the special specifications*.

Manual cutting

In the case of manual cutting, the machine shall be of an easily hand-held type, with a maximum weight of 6 kg and an impact frequency of > 50 Hz.

Cutting shall not be carried out directly on reinforcement.

Water-jetting

Selective water-jetting with water-jetting robots shall be carried out by companies that are approved in accordance with the Norwegian Public Roads Authority's approval scheme for water-jetting and with water-jetting equipment that is approved for selective water-jetting.

In the case of selective water-jetting, the equipment shall be calibrated against average cutting depth in accordance with *the special specifications*.

In the case of water-jetting of concrete to specified depths, the calibration shall be performed in such a way that this is possible in each individual case.

Good drainage of the water shall be ensured.

Miscellaneous

Concrete that is inadvertently removed to a larger extent than specified or remaining concrete and reinforcement that is damaged or loosened is the responsibility of the contractor and shall be repaired by the contractor without compensation.

Reinforcement work

Unless otherwise stated in *the special specifications*, exposed reinforcement can be cleaned by blast cleaning (sandblasting) to Sa 2 in accordance with NS-EN ISO 8501-1, i.e. almost all mill scale, rust and foreign particles shall be removed. When an exposed reinforcement surface has a high salt content (chlorides), it shall be cleaned with high-pressure hosing before blast cleaning. The reinforcement surface shall also be free of dust and loose particles. Exposed reinforcement that may have a high salt content on the reinforcement surface shall be cleaned using high-pressure hosing as close to the time of grouting/spray grouting/filling as possible.

Corrosion protection of reinforcement shall be carried out only using hand grouting when the reinforcement cover is less than the structure's specified reinforcement cover and it is stated in *the special specifications* that it shall be levelled flush with the concrete surface. Corrosion protection of reinforcement shall not be used when electro-chemical methods are used.

Corrosion protection shall cover the reinforcement thoroughly, including the back. The corrosion protection shall be applied the same day that cleaning has taken place. In environments where there is exposure to chloride, the corrosion protection shall be applied immediately after cleaning. The supplier's instructions shall be followed.

Removal of reinforcement is not permitted without approval from the Project Owner. Reinforcement that has been weakened or corroded shall be replaced with new reinforcement according to agreement with the Project Owner.

For limited mechanical repairs or topping where the existing reinforcement lies partly in carbonated or chloride-containing concrete, or if it is necessary in order to achieve satisfactory durability, stainless reinforcement shall be used.

Reinforcement that has loosened in connection with cutting shall be fixed in place again with the same shear load connector as before cutting.

Reinforcement work shall otherwise be carried out in accordance with Specification 84.3.

Pre-treatment

Hand-jettted surfaces shall be thoroughly sandblasted.

After mini-blasting, the flaw surfaces shall be cut clean with a jetting lance of an easily hand-held type, with a maximum weight of 6 kg and an impact frequency of > 50 Hz. Finally, the cut surfaces shall be thoroughly sandblasted.

Surfaces that are not cut but which are to be grouted/spray grouted/cast against shall, unless otherwise stated in *the special specifications*, be sandblasted thoroughly so that they have no surface skin or pollution and have a partially exposed aggregate and rough surface.

Immediately after water-jetting, surfaces shall be thoroughly cleaned with high-pressure hosing so that unhydrated cement does not set and prevent adhesion. If this is not done, further water-jetting shall be carried out with subsequent cleaning immediately afterwards. Shadows under reinforcement shall be removed with handheld equipment so that satisfactory recasting is ensured.

Formwork

Formwork shall be erected in accordance with Specification 84.2. Formwork shall be carried out so that when the formwork is removed, surfaces have a structure and colour like that of surrounding concrete surfaces.

Formwork shall fit closely to existing concrete at transitions and be stiff enough to ensure that there is an even transition in the surface between casting and existing concrete without disfiguring gaps or lips.

Cleaning/pre-wetting

The base layer shall be thoroughly pre-wetted at least one day before a cement-based adhesive layer is applied and grouting/spray grouting/filling commences. Existing concrete surfaces shall have a dry surface and be lightly absorptive when application takes place.

Immediately before grouting/spray grouting/casting, the base layer shall be cleaned and free of dust, cement mud, oil, free water etc.

Hand grouting/spray grouting/filling

The special specifications shall specify limits for the thickness of the hand grouting/spray grouting/filling so that the structure is not subjected to additional loads that would weaken its load-bearing capacity.

The air temperature during grouting/spray grouting/filling shall be between +5 and +25°C. Application may be carried out at temperatures above +25°C if special protective measures are initiated against the effects of direct sunlight and desiccation.

Hand grouting/ spray grouting/ filling shall take place as soon as possible after the base layer has been cleaned and 2 days at the latest after concrete removal and pre-treatment.

When the reinforcement is located such that screeding flush with the concrete surface results in a cover that is more than 10 mm less than the specified reinforcement cover for the structure (minimum cover), unless otherwise stated in *the special specifications*, hand grouting/spray grouting shall be carried out in such a way as to ensure the minimum coverage.

When hand grouting/spray grouting cut out flaws, grout shall not be applied to uncut surfaces so that it forms "lips" outside the edge of the cut out section.

Transitions between repairs and old concrete shall be worked so that they are even and without fissures or weak zones.

Unless otherwise stated in *the special specifications*, grout shall be applied by means of dry spraying or casting.

Hand grouting

If *the special specifications* specify hand grouting, an adhesive layer shall be brushed well into the base layer, also behind reinforcement, and cover all flaw surfaces.

The grout shall be applied wet-on-wet with an adhesive layer and such that the thickness for each layer does not exceed the maximum thickness in the supplier's instructions, and adapted to the shape of the flaw. Deeper flaws shall be built up in two or more layers immediately after the grout has set. Pre-wetting to the necessary extent shall take place between layers as stated for pre-wetting. If a long time passes between stages, an adhesive layer shall also be applied between the layers.

The grout shall be packed so that there is complete filling around the reinforcement.

Spray grouting

Before spray works begin, equipment and rigging as well as each individual spray operator shall be approved by the Project Owner.

The spray equipment shall have gearless capacity regulation with proportional regulation of water and dry matter. It must be possible to regulate the spray capacity down to a capacity low enough to ensure good filling around reinforcement.

Spray grouting shall not be carried out in strong winds due to the danger of separation.

Spraying shall always commence against a panel, box or similar until it can be verified visually that the water dose is correct.

When spraying commences, the entire flaw shall first be sprayed with a somewhat softer mass so that dust and rebound material do not lie on the surface and reduce adhesion.

On vertical or diagonal surfaces, spraying shall start at the bottom and continue upwards. An attempt shall be made to spray in such a way that the least possible dust sticks to the cleaned surface.

Layers thicker than the maximum thickness stated by the supplier shall not be sprayed in any spray session. Irregularities shall be scraped down gradually to prevent their propagating to the surface. The flaws shall be sprayed about 10 mm beyond the intended screeding level. The final layer shall be sprayed with a somewhat higher water content so that smoothing is easier.

The spray grout shall be well compacted and without layering, sand pockets or porous parts. Flawed spray grout shall be cut away and replaced by satisfactory material.

Spraying behind reinforcement shall be done at an angle and from a reduced distance so that sand pockets and shadow effects are avoided and good fill is ensured behind reinforcement.

Where there are large flaws, these shall if possible be sprayed against formwork to re-establish the previously existing shape.

The following requirements are made of the finished surface:

- 1) The finished sprayed surface without further work can constitute the final surface, but spraying should be done in such a way that there is as little unevenness and roughness as possible.
- 2) The finished sprayed surface is levelled with a straightedge and finished to give a surface like a float-finished surface.
- 3) The finished sprayed surface is levelled with a straightedge and finished so that it has a chippy surface structure.
- 4) The sprayed surface is polished, and additional grout added as necessary, so that major irregularities are corrected giving a surface like a float-finished surface.

Unless otherwise stated in *the special specifications* the surface shall satisfy the requirement in option 2.

"Chips", rebound loss and loose particles from sprayed grout on adjacent surfaces shall be removed while the grout is still fresh.

Casting

Casting of concrete is carried out in accordance with Specification 84.4 and *the special specifications*.

Finishing treatment (curing measures)

If it is specified in *the special specifications*, the formwork shall be pre-wetted in such a way that it remains moist until it is dismantled. Pre-wetting must not start so early that the grout or cast concrete is washed out.

Curing measures shall be chosen so that adhesiveness of the pre-treated surface is not significantly reduced by subsequent surface treatment.

Curing measures shall be initiated immediately after hand grouting/spray grouting/casting and work or the stripping of formwork.

Curing compound shall be applied as stated in Specification 84.541.

See Specification 84.54 and sub-specifications.

- d) The tolerance for evenness of hand grouted/spray grouted/cast surfaces is ± 10 mm.
- e) Cut surfaces and exposed reinforcement shall be inspected by the Project Owner before hand grouting/spray grouting/casting.

A check shall be made that the form of cut areas and exposed reinforcement satisfies requirements in Specification 88.32 c).

In the case of water-jetting, the following requirements apply to the remaining concrete:

- Free of hollow-sounding zones
- Aggregate shall split when hit with a hammer
- Small craters that are difficult to cast shall make up a maximum of 5% evenly distributed over the cut surface
- Free of shadows under reinforcement.

Hand grouting/spray grouting/casting

A visual inspection shall be made of the repaired surface when it is finished. The surface structure shall be virtually the same as surrounding concrete surfaces. In transitions between repairs and existing concrete, there shall be no gaps or lips against the existing concrete outside the cut flaw.

The surfaces shall be inspected for fissures and cracks. Repairs shall have no fissures or cracks with a width of more than 0.05 mm after a minimum of 28 days. If surface treatment is applied that makes later inspection impossible, the requirement shall be enforced at the time of application.

An inspection using hammer blows shall be carried out to ensure that there are no flawed areas in repaired areas. This inspection shall be performed 14-28 days after hand grouting/spray grouting/casting.

In repaired areas, the adhesive strength shall be controlled by means of a pull-off test after 14-28 days.

Adhesive testing shall be done in accordance with method 15.541 in Handbook 015 Field investigations. A series of tests consists of three individual tests. Adhesive strength shall be greater than or equal to 1.2 MPa, and no single test result shall be less than 1.00 MPa. In the case of a break in the base layer, an assessment shall be made of whether it is due to the quality of the concrete base or to chiselling/pre-treatment.

One test series shall be carried out for each 20 m² of repaired surface or part thereof. If the five last test series satisfy the requirements, the test frequency may be set at one test series for each 100 m² of repaired surface. If the adhesiveness requirement is not satisfied, further measures shall be clarified with the Project Owner. Flawed adhesiveness as a result of poor workmanship shall normally not be accepted.

All holes from sampling shall be carefully refilled and levelled flush with the adjacent concrete surface as specified in Specification 88.327.

For cast concrete see Specification 84.4. Unless otherwise stated in *the special specifications*, fissure gaps shall in repaired areas shall not exceed 0.1 mm.

The specified testing extent is appropriate for large works where scaffolding remains standing and ensures access for work. For smaller repairs, where scaffolding is removed immediately after repairs, the extent of testing and execution shall be specially adapted in accordance with *the special specifications*.

- x) Quantity shall be measured as complete volume of repaired concrete. (If necessary, Specifications 88.3281 - 88.3285 shall be used, and if relevant also a specification of quantities under each individual sub-operation).

Rules for the calculation of volume

Charging for defects larger than 0.1 dm³ is based on volume. If area supplements (Specification 88.3284) are used, defects with a volume less than 0.1 dm³ (litre) shall be charged for in terms of area supplement only.

Surface damage

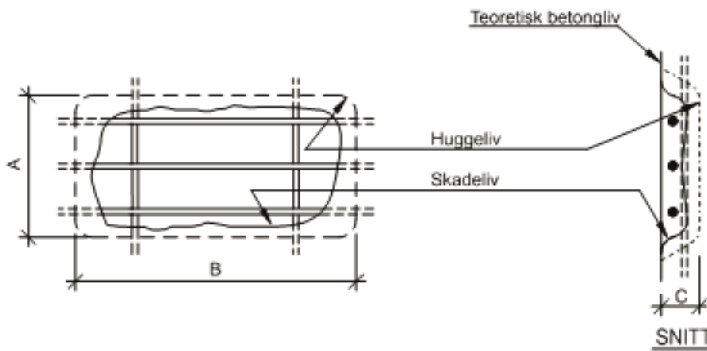

Teoretisk betongliv = theoretical concrete surface
 Huggeliv = extent of cut
 Skadeliv = extent of damage
 SNITT = cross section

C = Average depth to which the surface has been cut
 Volume repaired = A x B x C dm³ (litre)

Corner damage

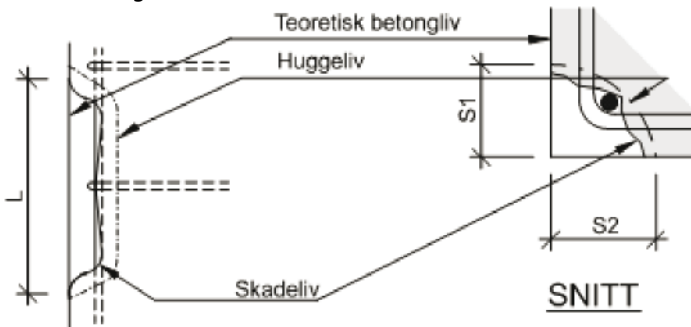

Job account volume = 1/2 x S² x L dm³ (litres)
 S_m = 1/2 x (S₁ + S₂)

Largest side edge S necessary for a flaw to be counted as corner damage is 4 dm.

Edge damage – plate wing

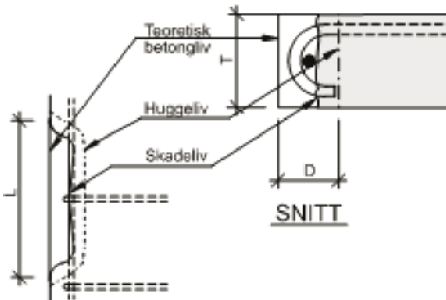

Edge damage - UK beam

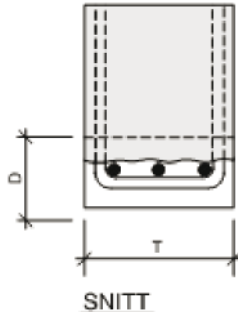

Job account volume = $D \times T \times L \text{ dm}^3$ (litres)
Unit: dm^3 (litres)

88.321 Inspection

- a) Comprises inspection of the concrete surface and marking of damage to be repaired.
- x) Quantity shall be measured as inspected area. Unit: m^2

88.322 Reference fields

- a) Comprises the establishment of reference fields.
- b-e) See *the special specifications*.
- x) Quantity shall be measured as number of reference fields. Unit: No.

88.323 Removal of concrete

- a) Comprises removal and depositing of concrete.
- b-e) See *the special specifications*.
- x) Quantity shall be measured as the volume of concrete removed using the volume calculations as in Specification 88.32. Any supplements are covered by 88.3281-88.3285. Unit: dm^3 (litre)

88.3231 Mechanical chiselling

- a) Comprises mechanical chiselling of concrete.
- x) As in Specification 88.323. Unit: litre

88.3232 Mini-blasting

- a) Comprises mini-blasting of concrete and mechanical chiselling as finishing work.
- x) As in Specification 88.323. Unit: litre

88.3233 Water-jetting

- a) Comprises chiselling of concrete and cleaning of damaged surfaces with water-jetting.
- x) As in Specification 88.323. Unit: litre

88.324 Reinforcement work

- a) Comprises cleaning of reinforcement, corrosion protection of reinforcement, extra reinforcement to replace damaged reinforcing bars and reinforcement of topping.
- b-e) As in Specification 84.3 and *the special specifications*.
- x) Quantity shall be measured as length of reinforcement. Unit: m

88.3241 Cleaning of reinforcement

- a) Comprises cleaning of reinforcement before spraying/filling.
- x) Quantity shall be measured as length of cleaned reinforcing bars. Unit: m

88.3242 Application of corrosion protection

- a) Comprises application of corrosion protection on cleaned reinforcement.
- x) Quantity shall be measured as length of reinforcing bars to which corrosion protection is to be applied. Unit: m

88.3243 Extra reinforcement

- a) Comprises installation of extra reinforcement to replace damaged reinforcing bars.
- x) Quantity shall be measured as length of installed new reinforcement. Unit: m

88.3244 Reinforcement of toppings

- a) Comprises reinforcement of toppings
- b-e) As in Specification 84.3.
- x) Quantity shall be measured as tons of reinforcement used. Unit: ton

88.3245 Drilling and injection grouting of dowels and splicing bars

- a) Comprises drilling, injection grouting of dowels/splicing bars. Delivery of dowels and splicing bars is included in Specification 88.3244.
- b) The injection grout for grouting dowels/splicing bars shall be of a quality that ensures solid, permanent anchoring in the specified drillhole (length and diameter).
- c) Drilling shall be carried out in accordance with Specification 88.326. Hole diameter shall be chosen in accordance with recommendations from the materials supplier for the respective diameters of reinforcement rods that are to be grouted and the length of the holes to be grouted.

Grouting shall be carried out in accordance with the product supplier's instructions. It shall be possible to load grouted reinforcement rods to flow without fracture in grouting.

If there is a risk of macro-cell corrosion between new and old reinforcement, special measures to prevent this shall be stated in *the special specifications*. There shall be no electrical contact between new and old reinforcement.
- e) If grouted reinforcement rods are important for the load-bearing capacity, dowels/splicing bars shall be test loaded. The scope and method used shall be stated in *the special specifications*.
- x) Quantity shall be measured as number of dowels/splicing bars. Unit: No.

88.325 Grouting/spray grouting/casting

- a) Comprises pre-treatment, formwork, cleaning and pre-wetting, hand grouting/spray grouting/casting and finishing treatment (curing measures).
- x) As in Specification 88.32. Unit: dm³ (litre)

88.3251 Pre-treatment

- a) Comprises pre-treatment of concrete surfaces with sandblasting or water-jetting before hand grouting/spray grouting/casting.
- c) Pre-treated concrete surfaces shall have no surface skin etc. and shall have an evenly rough surface with partly exposed aggregate that provides good adhesion.
- x) Quantity shall be measured as area treated. Unit: m²

88.32511 Pre-treatment using sandblasting

- a) Comprises pre-treatment of concrete surfaces with sandblasting.
- x) As in Specification 88.3251. Unit: m²

88.32512 Pre-treatment using water-jetting

- a) Comprises pre-treatment of concrete surfaces with water-jetting.
- x) As in Specification 88.3251. Unit: m²

88.3252 Formwork

- a) Comprises formwork for hand grouting/spray grouting/casting.
- x) Quantity shall be measured as area covered by formwork. Unit: m²

88.3253 Cleaning and pre-wetting

- a) Comprises cleaning and pre-wetting of all concrete surfaces that are to be hand grouted/sprayed/cast against.
- x) Quantity shall be measured as area cleaned and pre-wet surface. Unit: m²

88.3254 Hand grouting

- a) Comprises repair by hand grouting, any adhesive layer and working of the hand-grouted surface.
- x) As in Specification 88.32. Unit: dm³ (litre)

88.3255 Spray grouting

- a) Comprises repair by spray grouting and working of the spray grouted surface.
- x) As in Specification 88.32. Unit: dm³ (litre)

88.3256 Casting

- a) Comprises repair by casting and working of the cast surface.
- x) As in Specification 88.32. Unit: dm³ (litre).

88.3257 Finishing treatment (curing measures)

- a) Comprises finishing treatment/curing measures for hand grouted/spray grouted/cast concrete surfaces.
- x) Quantity shall be measured as area post-treated surface. Unit: m²

88.326 Drilling in concrete

- a) Comprises drilling holes in concrete.
- b-c) Clean freshwater shall be used to cool the drill.

Unless otherwise stated in *the special specifications*, the contractor may choose the drilling method. Reinforcement shall be located using a covermeter, and holes adjusted so that the least possible reinforcement is cut.

Care shall be taken to avoid harming tensioned reinforcement. Tensioned reinforcement shall be measured and marked on the basis of "as built" drawings before drilling. If drilling is to be carried out near tensioned reinforcement, chiselling in to the tensioning duct shall be carried out before drilling starts. Drilling shall be discontinued and core broken flush with the tensioning duct for visual inspection of the break surface so that drilling into the tensioned reinforcement is avoided. If the drill bit sticks on a level with the tensioning duct, drilling shall immediately be discontinued, the core broken out and the break surface inspected.

When drilling through sections, the drill shall be fed carefully towards the end in order to avoid chipping the concrete around the drillhole.

See also *the special specifications*.

- x) Quantity shall be measured as number of drilled holes. (In the case of different diameters and drilled lengths, quantities for each drill diameter and drilled length shall be stated.) Unit: No.

88.3261 Drilling with masonry drills

- a) Comprises drilling with masonry drills.
- x) As in Specification 88.326. Unit: No.

88.3262 Drilling with core drills

- a) Comprises drilling with core drills.
- x) As in Specification 88.326. Unit: No.

88.327 Packing/refilling of drillholes

- a) Comprises packing/refilling of drillholes in concrete.
- b) See Specification 88.32.

Drillholes with a diameter < 25 mm can be refilled with grey, overpaintable single component polyurethane joint filler or suitable cement grout.

Grout that is used to repair larger holes from core drilling etc. shall satisfy the requirements for hand grouting in Specification 88.32. Film-forming coatings shall satisfy the requirements in Specification 88.37.

- c) See Specification 88.32.

Drillholes with a diameter < 25 mm

Drillholes shall be blown empty of dust and completely filled using a joint pistol to pump into the hole through a tube that is pressed to the bottom of the hole and gradually withdrawn as the hole is filled.

Drillholes with a diameter > 25 mm

Holes from core drilling shall be cleaned of dust and loose particles, pre-wetted and dried of free water. Repair grout shall be mixed to a suitable consistency and the hole filled to 20-30 mm from the surface. After the grout has set, the hole shall be grouted flush with the surface

A film-forming coating of the same colour as the adjacent concrete surface shall be immediately applied. See also *the special specifications*.

- x) Quantity shall be measured as number of packed/refilled holes. (If there are different diameters and depths, the quantities for each hole diameter and depth shall be stated.) Unit: No.

- 88.3271 Packing/refilling of small drillholes**
- a) Comprises packing/refilling of drillholes with a diameter < 25 mm.
 - x) As in Specification 88.327. Unit: No.
- 88.3272 Packing/refilling of large drillholes**
- a) Comprises packing/refilling of drillholes with a diameter > 25 mm.
 - x) As in Specification 88.327. Unit: No.
- 88.328 Supplement, special work operations**
- a) Supplement for special work operations is included in the specification.
 - x) Costs shall be given as a lump sum. Unit: LS
- 88.3281 Volume supplement for repairs, for areas from 9 dm² to 50 dm²**
- a) Comprises a volume supplement for complete repair of damaged areas in the concrete surface larger than 9 dm² and less than 50 dm² ($9.0 \text{ dm}^2 < A \times B < 50.0 \text{ dm}^2$).
 - x) Quantity shall be measured as number of damage spots. Unit: No.
- 88.3282 Volume supplement for repairs, for areas from 1 dm² to 9 dm²**
- a) Comprises a volume supplement for complete repair of damaged areas in the concrete surface larger than 1 dm² and less than 9 dm² ($1.0 \text{ dm}^2 < A \times B < 9.0 \text{ dm}^2$).
 - x) Quantity shall be measured as number of damage spots. Unit: No.
- 88.3283 Volume supplement for repairs, for areas less than 1 dm²**
- a) Comprises a volume supplement for complete repair of damaged areas in the concrete surface less than 1 dm² ($A \times B < 1.0 \text{ dm}^2$).
 - x) Quantity shall be measured as number of damage spots. Unit: No.
- 88.3284 Area supplement for repair of damage spots**
- a) Comprises an area supplement for complete repair of damage where chiselled volume is not measured, for example removal of nails, steel wire and so forth.
 - x) Quantity shall be measured as number of damage spots. Unit: No.
- 88.3285 Supplement for repairs behind reinforcement**
- a) Comprises supplementary costs for removal of concrete in depths behind reinforcement.
 - x) Quantity shall be measured as volume of repaired concrete behind the outer layers of load-bearing structural reinforcement (not installation bars). Unit: dm³ (litre)
- 88.33 Repairs below water**
- a) Comprises maintenance of reinforced and unreinforced concrete below water and in the tidal zone. Removal of any remaining formwork is included in Specification 88.235.
 - b-e) See Specifications 84.28, 84.3 and 84.43 including sub-specifications, Specification 88.32 and Norwegian Concrete Association Publication No. 5: Project planning and production of concrete structures in water.
- Repairs shall be performed using materials and according to methods in *the special specifications*.
- Unless otherwise stated in *the special specifications*, the materials used for repairs shall be AWO concrete or AWO grout. Castability to ensure adhesion and water-proofing shall be good.
- All porous, flawed concrete shall be removed. The upper face of the damaged area shall be cut to a 45° angle so that water and mud can escape and the entire flaw shall be filled with sound concrete.
- Concrete surfaces that are to be cast against shall be thoroughly cleaned before casting. This also applies to non-cut surfaces.
- Unless otherwise stated in *the special specifications*, all repairs carried out below water shall be carried out as pump or pipe casting.
- See also Specification 88.32 and *the special specifications*.
- x) As in Specification 88.32. Unit: dm³ (litre).
- 88.331 Removal of concrete**
- a) Comprises removal of concrete below water.
 - x) As in Specification 88.32. Unit: dm³ (litre).

- 88.332 Pre-treatment**
- a) Comprises pre-treatment below water by means of sandblasting or water-jetting before casting.
 - x) Quantity shall be measured as pre-treated area. Unit: m²
- 88.333 Reinforcement below water**
- a) Comprises reinforcement below water. Also comprises drilling and grouting of dowels and splicing bars.
 - x) Quantity shall be measured as installed reinforcement weight. Unit: ton.
- 88.334 Formwork below water**
- a) Comprises formwork below water.
 - x) Quantity shall be measured as area of formwork surface. Unit: m²
- 88.335 Casting**
- a) Comprises casting below water.
 - x) Quantity shall be measured as volume of cast concrete. Unit: dm³ (litre).
- 88.336 Repairs using special grouts**
- a) Comprises repair of minor flaws and casting flaws below water.
 - b) Materials shall be chosen on the basis of the type of flaw and the local conditions. See *the special specifications*.
 - c) Minor flaws and casting flaws shall be repaired to at least 0.1 m beyond the flaw along all faces and to a repair thickness of at least 0.15 m beyond the existing surface. Depending on the extent and size, repairs shall be carried out using scip/bucket, pump or pipe casting. See also *the special specifications*.
 - x) Quantity shall be measured as volume of cast concrete. Unit: dm³ (litre).
- 88.337 Injection and injection grouting**
- a) Comprises injection and injection grouting of cavities and fissures/cracks below water.
 - b-c) Materials and methods shall be chosen according to the type of damage and local conditions. See also *the special specifications*.
 - x) Quantity shall be measured as linear metres of injected fissure/crack. Unit: m
- 88.338 Grouting of foundations**
- a) Comprises grouting of foundations after erosion (scouring). Any erosion protection is included in Specification 88.267.
 - b) Rock materials and cemented materials (concrete, mortar, grouting mortar) shall meet all requirements in *the special specifications*.
 - c) Grouting methods shall be chosen according to the type of flaw and local conditions, for example packing with specially graded rock masses and injection with laitance, packing with concrete in sacks, masonry with rock and stiff mortar, grouting with special concrete etc.
 - x) Costs shall be given as a lump sum. Unit: LS
- 88.34 Repair of fissures and cracks**
- a) Comprises repair of fissures and cracks above water.
 - b-c) The materials chosen must have properties documented as being consistent with the requirements in *the special specifications*. Choice of materials and methods shall be in accordance with recommendations from the material supplier.

Any requirements with respect to appearance are stated in *the special specifications*.

See also *the special specifications*.
 - x) Quantity shall be measured as linear metres of repaired fissure/crack. Unit: m
- 88.341 Painting of fissures/cracks**
- a) Comprises painting or filling of dry fissures/cracks with suitable material on horizontal surfaces.
 - b) See *the special specifications*.
 - c) To be carried out in dry fissures/cracks on horizontal surfaces. Fissures/cracks shall be treated repeatedly until saturated. See also *the special specifications*.
 - x) Quantity shall be measured as linear metres of painted fissure/crack. Unit: m

88.342 Sealing of fissures/cracks

- a) Comprises sealing of fissures and cracks.
- b-c) Sealing is done by applying a layer over the fissure/crack. For selection of materials and methods, see *the special specifications*.
- x) Quantity shall be measured as linear metres of sealed fissure/crack. Unit: m

88.343 Injection

- a) Comprises injection of fissures and cracks.
- b) Injection shall be carried out using low viscosity injection material that can penetrate and seal fine fissures. See also *the special specifications*.
- c) The fissure/crack shall be sealed and the injection agent pumped into the crack via nipples that have been installed in drillholes (injection ports). The holes shall drilled from either side of the fissure/crack alternately. The nipples must not be so deeply inserted that they block the fissure/crack.

In the case of fissures/cracks that go right through the section, both sides of the section to be injected shall be sealed.

The injection agent shall be pumped in from the lowest nipple until it emerges from the nipple above, etc. The injection pressure must not be so great that it could lead to the destruction of the structural component.

After injection is finished, projecting nipples and sealing shall be removed. Unevennesses shall be eliminated with filler.

For requirements regarding the appearance of surrounding surfaces after injection, see *the special specifications*.

- e) To document how successful an injection has been, post-injection testing shall be carried out, for example core drilling in accordance with *the special specifications*.
- x) Quantity shall be measured as linear metre of injected fissure/crack. Unit: m

88.344 Re-concreting of fissures/cracks

- a) Comprises breaking up the surface, cleaning and re-concreting of fissures/cracks.
- b-c) As in Specification 87.32. Fissures/cracks shall be broken up, reinforcement and flawed surfaces cleaned and repaired with suitable mortar. See also *the special specifications*.
- x) Quantity shall be measured as linear metres of re-concreted cracks. Unit: m

88.345 Repair of movable cracks

- a) Comprises repair of movable cracks.
- b) A joint filler or membrane shall be used that can absorb the movement in question. See also *the special specifications*.
- c) If it is possible with respect to reinforcement cover, joint filler shall be placed in cut grooves. The distance between the bottom of the groove and crossing reinforcement shall be a minimum of 20 mm in order to be acceptable. A joint filler groove shall be cut with a width and depth as specified by the supplier of the joint filler. The groove shall be made perpendicular to the concrete surface.

Surfaces in joint grooves shall be thoroughly cleaned before filling.

See also *the special specifications*.

- x) The quantity shall be measured as linear metres of repaired crack. Unit: m

88.35 Re-alkalising/chloride extraction

- a) Comprises electrochemical re-alkalising and chloride extraction.
Necessary mechanical repairs to the concrete are included in Specification 88.32.
Surface treatment is included in Specification 88.37.
- c) All necessary mechanical repairs shall have been carried out before re-alkalising/chloride extraction.
In the case of any welding of reinforcement to ensure reinforcement continuity, the existing reinforcement must be checked for weldability. Welding shall be done on shear reinforcement. Welding on main reinforcement is not permitted unless special conditions make it necessary, and must in the event be clarified with the Project Owner in advance.
- x) Quantity shall be measured as treated surface. Unit: m²

88.351 Re-alkalising

- a) Comprises electrochemical re-alkalising.

Electrochemical re-alkalising will, unless otherwise stated in *the special specifications*, comprise the following sub-operations:

- Check of reinforcement continuity and establishment of reinforcement continuity if necessary
- Check of discontinuity and any measures to prevent short circuiting
- Establishing conduction contacts to the reinforcement.
- Installation of an electrode network (titanium network unless otherwise stated in the special specifications)
- Installation of reservoir and electrolyte
- Wetting with electrolyte
- Connecting the current
- Adjustment and monitoring of current/voltage
- pH testing
- Disconnecting the current
- Removal of the electrode network and electrolyte
- Documentation
- Follow-up work.

- b-e) See NS 3420 chapter L82, CEN/TS 14038-1 and *the special specifications*.

- x) Quantity shall be measured as re-alkalised surface area. When calculating the network area, openings and recesses that individually are less than 0.5 m² shall not be subtracted. Unit: m²

88.352 Chloride extraction

- a) Comprises electrochemical chloride extraction.

Unless otherwise stated in *the special specifications*, electrochemical chloride extraction will comprise the following sub-operations:

- Detail design
- Reference field, if any
- Check of reinforcement continuity and establishment of reinforcement continuity if necessary
- Check of discontinuity and any measures to prevent short-circuiting
- Establishment of conduction contacts to the reinforcement.
- Marking places for chloride analyses and first time analysis of chloride content
- Installation of an electrode network (titanium network unless otherwise stated in the special specifications)
- Installation of reservoir and electrolyte
- Wetting with electrolyte
- Connecting the current
- Adjustment and monitoring of current/voltage
- Analysis of chloride content at regular intervals
- Disconnecting the current
- Removal of electrode network and electrolyte
- Documentation
- Follow-up work

- b-e) See NS 3420 chapter L83 and *the special specifications*.

- x) Quantity shall be measured as protected surface area. When calculating the network area, openings and recesses that individually are less than 0.5 m² shall not be subtracted. Unit: m²

88.36 Cathodic protection

- a) Comprises cathodic protection of reinforcement in concrete above and below water.

Cathodic protection includes the following work operations unless otherwise stated in *the special specifications*:

- Detail design
- Reference field, if any
- Check of reinforcement continuity and short-circuit monitoring
- Concrete work for cabling and connections
- Concrete work for instrumentation
- Concrete work for anode system
- Commissioning and final documentation
- Operations and maintenance

Necessary mechanical repair of concrete is included in Specification 88.32. Delivery and installation of cables, instrumentation, anode system, T/L-unit and control and monitoring systems are included in Specification 88.7611.

- b-e) Materials that do not reduce the effect of cathodic protection shall be used for mechanical repairs.

In the case of any welding of reinforcement to ensure reinforcement continuity, the existing reinforcement must be checked for weldability. Welding shall be done on shear reinforcement. Welding on

main reinforcement is not permitted unless special conditions make it necessary, and must in the event be clarified with the Project Owner in advance.

See also NS-EN 12696-1 and *the special specifications*.

- x) Quantity shall be measured as protected surface area. When calculating the network area, openings and recesses that individually are less than 0.5 m² shall not be subtracted. Unit: m²

88.37 Surface treatment of concrete

- a) Comprises surface treatment of concrete.

Unless otherwise stated in *the special specifications*, comprises the following work operations:

- Reference field if specified
- Pre-treatment of concrete surfaces
- Application of surface treatment
- Finishing treatment (curing)

- b) Materials shall have documented qualities that satisfy the specified protection requirements.

General material requirements

The contractor shall document that the materials chosen satisfy the specified requirements.

The materials shall be transported, handled and stored in such a way that the quality of the finished product is not impaired. They shall be stored and marked so that different product types and grades cannot be confused or mixed together.

All materials shall be alkali- and frostresistant.

All materials that are used for surface treatment shall be compatible with one another. Materials from the same supplier shall preferably be used to ensure this. If the contractor wishes to carry out repairs using materials from different suppliers, documentation that they are compatible shall be submitted to the Project Owner for comment.

Water

All water used for cleaning, chiselling, pre-wetting etc. shall be freshwater that does not contain substances that are harmful to fresh or cured reinforced concrete.

Compressed air

Compressed air shall not contain oil.

Chemical paint removal/cleaning

Substances used in chemical paint removal/cleaning shall not damage the underlying concrete.

Surface treatment

General

If concrete surfaces that are to receive surface treatment have a high alkalinity as a result of re-alkalisation, the surface treatment must tolerate this.

Water-repellent impregnation

The impregnation material's properties shall be documented in accordance with Norwegian Road Authority's Technology Department internal report no. 2034: Documentation requirements for chloride-inhibiting products for surface treatment of concrete.

Water-repellent impregnation shall be carried out with clean silanes without solvents, and with a molecule length that permits good penetration into damp concrete.

The impregnation material shall meet the following requirements:

Table 88.37-1		
Property	Test method	Requirements
Resistance to chloride penetration	SINTEF MB 71301	>75% reduction in relation to the reference
Depth of penetration	SINTEF MB 71301	Average penetration depth for a sample shall be minimum 1 mm and for each individual core sample minimum 0.5 mm
Asphalt solubility	SINTEF KS 70125 or equivalent method.	No solution. Only relevant when the product may come into contact with asphalt.

Film-forming coatings

Film-forming coatings shall satisfy the requirements in the Norwegian Road Authority Technology Department's internal report no. 2034: Documentation requirements for chloride-inhibiting products for surface treatment of concrete.

Film-forming coatings shall meet the following requirements:

Table 88.37-2		
Property	Test method	Requirements
Resistance to chloride penetration	SINTEF MB 71301	>75% reduction in relation to the reference
Tensile strength	NS-EN ISO 4624	>0.8 MPa at 20°C
Bond strength	NS-EN ISO 4624	>1.2 MPa or the material's tensile strength
Carbonation resistance	NT Build 300	>90% reduction after 16 weeks
Water vapour permeability	NT Build 369	0.5×10^{-12} kg/msPa
UV durability	ASTM G53 1990	Class m ² /g ² according to DIN 209
Fissure covering property	ZTV SIB 90 TP OS	Class III T

Other surface treatment/Anti-graffiti treatment

Other types of surface treatment and anti-graffiti treatment shall satisfy relevant requirement for water-repellent impregnation and film-forming coatings. Requirements that deviate from this and other requirements shall be specified in *the special specifications*.

- c) Execution of all work shall be in accordance with the specifications and the supplier's technical data sheet. Where there are discrepancies between the specifications and the data sheet, the Project Owner shall be informed and a choice made in consultation with the supplier.

The following requirements apply to weather conditions for execution of the work:

- Surface temperature: +5°C<T<+30°C and falling
- Air temperature during execution: +5°C<T<+30°C and falling
- Relative humidity, maximum 95%
- Wind velocity maximum 10 m/s
- Direct sunlight and temperature increases on the surface shall be avoided.

Immediately after application, the treated area shall be covered if this is necessary to give satisfactory drying and curing conditions, as well as protection against sun, wind and precipitation.

Reference field

Purpose of reference fields:

- To verify that the work will be carried out with satisfactory workmanship.
- To check that work procedures in the quality assurance programme provide satisfactory results or whether they must be changed
- To reveal unforeseen factors that entail a need for new work procedures or changes in work procedures.
- To act as a consensual reference for satisfactory execution after various work operations. The reference field must thus remain exposed so that it can be used throughout the work period.

In general, reference fields shall be established using all critical or repetitive work procedures before the startup of work on a large scale. Reference fields shall be approved by the Project Owner before further work can be initiated.

It must be documented on the reference field that all requirements with respect to execution and inspection are fulfilled. The location and size of the reference field shall be stated in *the special specifications*.

Pre-treatment

Pre-treated surfaces shall provide sufficient penetration depth for impregnation and adhesion for film-forming coatings. Unless otherwise specified in *the special specifications*, all existing surface treatments shall be completely removed down to clean concrete. Cleaned surfaces shall be free of sand, loose particles, cement sludge, soot, dirt, oil, curing compound, chemical residues, moss, algae etc. in as far as it is possible to remove these. If electrochemical methods have been used, all residues from reservoirs, electrolytes, corrosion products on the surface of the concrete from the electrode net, and salts on the surface of the concrete shall be removed.

Unless otherwise stated in *the special specifications*, pre-treatment shall be carried out consisting of thorough sandblasting, possibly with some water added to reduce dust.

Surface treatment

Water-repellent impregnation

Impregnation shall be carried out at stable or falling temperatures and on an absorbent underlay. The impregnation material shall be sprayed using compressed air equipment. The surface shall be as dry as possible when it is sprayed, and at least "light grey dry".

Spray application shall start from the top. The spraying rate shall be governed by checking that the downward flow is 30-40 cm. Two impregnation coats shall be sprayed as two coats with a drying time between coats as specified by the supplier. The use of impregnation shall normally be 0.1-0.2 kg/m² for each coat. If an application is interrupted, the surface must be marked so that no spots remain untreated when application recommences.

Application of gel- or cream-based impregnation shall be carried out as specified by the supplier.

Film-forming coatings

Surface treatment shall close all pores and cracks in the surface so that a pore- and crack-free surface results.

Two coats of surface treatment shall be applied on primed, dry but sticky surface (normally after 2-24 hours). Unless otherwise stated by the supplier, the first coat shall use approximately 2 kg/m², and the total amount used shall be 3.5 kg/m². The first coat shall be used as pore filler and shall be spread by means of a squeegee. The second coat shall be applied when the first coat has sunk in, i.e. after 1-6 hours. The treatment may be applied by spraying, but shall be spread using a brush. All levelling shall be straight and ensure good water drainage.

Spraying equipment: Small monopump (sand filler spray gun), spray nozzle and compressed air.

Other surface treatment

Shall be carried out as specified for water-repellent impregnation and film-forming coatings when relevant and as specified in *the special specifications*

e) **Before cleaning**

Mechanical repairs shall be carried out before cleaning. Surfaces that are to receive surface treatment shall be inspected visually. Unless otherwise stated in *the special specifications*, all foreign bodies on the concrete surface shall be removed as part of the mechanical repair. This applies to nails, wire, woodchips etc.

Cleaning

Cleaned surfaces shall be inspected visually before application. The concrete surface shall be clean and dry without contaminants.

Cleaned surfaces shall allow good penetration or adhesion of the surface treatment chosen. If there are requirements with respect to adhesion for the subsequent surface treatment, the concrete base's tensile strength after cleaning shall be checked by means of pull-off tests. One series of tests consisting of 3 individual strips shall be made for every 50 m² or part thereof. If the 5 previous test series satisfy requirements, the testing frequency can be reduced to 1 test series for every 500 m².

The requirement for the concrete base's tensile strength shall be a minimum of 1.2 MPa for each test, no individual pull-off under 1.0 MPa.

If the requirement regarding the concrete surface's tensile strength is not met, further, improved cleaning and testing shall be carried out. If the requirement is still not met, an evaluation shall be made of what tensile strength the concrete grade making up the base layer is capable of.

Surface treatment

Water-repellent impregnation

During application, an ongoing overview shall be maintained of the amount used for each application and application section.

The penetration depth shall be checked by drilling cores with a minimum diameter of 60 mm, splitting the cores and using water as an indicator to measure penetration depth. One test consists of 3 cores. The penetration depth is read off by means of a crack magnifier at a minimum of 10 points on each half core. An average is calculated for each half core. A more precise method may also be used. The requirement for average penetration depth is 1 mm for each test. No half core shall show an average penetration depth of less than 0.5mm. One test series shall be taken for each 50 m² or part thereof. If the previous 5 test series satisfy the requirement, the testing frequency can be reduced to 1 test series for every 250 m².

Penetration depth shall be measured the day after the last coat has been applied. Documentation of satisfactory penetration depth can also be based on testing at a later point in time if the material supplier has specified this. In this case, penetration depth the day after the last coating was applied shall be measured nonetheless, for use as a "preliminary verification criterion".

Film-forming coatings

During application, an ongoing overview shall be maintained of the amount used for each application and application section.

A visual inspection of the surface shall be made after application. The surface shall not have visible pores, cracking, fissures or conspicuous colour variations.

Adhesion shall be checked with a pull-off test 14 days after application in accordance with Handbook 015 Field investigations, method 15.541. A test series consists of three individual strips.

When testing, the portion of the rupture that is in the base layer, the adhesion zone or the coating material itself shall be recorded. The requirement for adhesive strength if the break is completely or partly in the base layer or adhesion zone is a minimum of 1.2 MPa at 20°C for each test and for the individual strip less than 0.8 MPa. One test series shall be taken for each 50 m² or part thereof. If the previous 5 test series satisfy the requirement, the testing frequency can be reduced to 1 test series for every 250 m².

After stripping, the surface shall be treated in the area where the stripping has taken place.

Other surface treatment

As specified for water-repellent impregnation and film-forming coatings when this is relevant and as specified in *the special specifications*.

- x) Quantity shall be measured as cleaned and surface-treated area. When calculating network area, openings and recesses that individually are less than 0.5 m² shall not be deducted. Unit: m²

88.371 Cleaning of surfaces

- a) Comprises cleaning of concrete surfaces before application of surface treatment.

- x) As in Specification 88.37. Unit: m²

88.372 Brush coating with slurry

- a) Comprises brush coating of concrete surfaces with slurry.

- b-e) See *the special specifications*.

- x) As in Specification 88.37. Unit: m²

88.373 Pore-filling

- a) Comprises filling of pores and spackling of concrete surfaces.

- b-e) All the pores in the concrete surface shall be filled.

See also *the special specifications*.

- x) As in Specification 88.37. Unit: m²

88.374 Finishing

- a) Comprises finishing of concrete surfaces.

- b-e) See *the special specifications*.

- x) As in Specification 88.37. Unit: m²

88.375 Water-repellent impregnation

- a) Comprises water-repellent impregnation of concrete.

- x) As in Specification 88.37. Unit: m²

88.376 Surface treatment using film-forming coatings

- a) Comprises surface treatment using film-forming coatings.

- x) As in Specification 88.37. Unit: m²

88.377 Anti-graffiti treatment

- a) Comprises removal of graffiti and application of anti-graffiti treatment.

- b-e) Materials and methods that have the least possible effect on the concrete surface shall be used to remove graffiti.

See also *the special specifications*.

- x) As in Specification 88.37. Unit: m²

88.3771 Removal of graffiti

- a) Comprises removal of graffiti.

- x) As in Specification 88.37. Unit: m²

88.3772 Anti-graffiti treatment

- a) Comprises anti-graffiti treatment.

- x) As in Specification 88.37. Unit: m²

- 88.378 Other surface treatment**
- a) Comprises other surface treatment.
 - b-e) See *the special specifications*.
 - x) As in Specification 88.37. Unit: m²
- 88.38 Other maintenance of concrete**
- a) Comprises other concrete maintenance.
 - x) Costs shall be given as a lump sum. Unit: LS
- 88.381 Delivery and mounting of weather cowls**
- a) Comprises delivery and mounting of weather cowls.
 - b) Prefabricated weather cowls in a UV resistant material unless otherwise stated in *the special specifications*.
 - c) Weather cowls shall be installed on a concrete base that has been cleaned by sandblasting.
The gap between the weather cowl and the concrete shall be completely filled with glue/joint filler so that no voids occur. The bond shall be watertight.
 - d) Weather cowls shall have an even alignment without disfiguring deviations.
 - e) A check shall be made that the weather cowl is firmly attached after the joint filler/glue has dried/hardened.
 - x) Quantity shall be measured as length of supplied and installed weather cowls. Unit: m
- 88.4 Steel works**
- a) Comprises maintenance of structures and structural components of steel.
 - b-e) As in Specification 85 and *the special specifications*.
 - x) Costs shall be given as a lump sum. Unit: LS
- 88.41 Rigging, scaffolding and protection**
- a-c) As in Specification 88.31.
 - x) Costs shall be given as a lump sum. Unit: LS
- 88.411 Rigging and scaffolding**
- a) Comprises rigging and scaffolding.
 - x) Costs shall be given as a lump sum. Unit: LS
- 88.412 Protection/cover**
- a) Comprises protection/cover and any heating/air conditioning necessary to satisfy requirements concerning collecting up of waste materials and satisfactory conditions for corrosion protection work.
 - c) Frames with light tarpaulins and similar are not permitted as cover. The cover shall be so comprehensive that the structure is fully enclosed and such that sand from sand-blasting and all other waste can be collected for transport to a special waste depot.

If the cover results in the structure being subjected to extra wind forces, static calculations shall be carried out to check that the structure will tolerate a higher wind load. These shall be submitted to the Project Owner for verification.
 - x) Costs shall be given as a lump sum. Unit: LS
- 88.42 Inspection**
- a) Comprises inspection in connection with maintenance work.
 - c) If maintenance or replacement of corrosion protection on steel forms part of the works, a visual inspection shall be carried out after cleaning/bast cleaning.

All damage/deficiencies in the steel structure such as cracks, rolling defects, welding defects, delaminations, sharp corners, corrosion with cross-section reductions, wire breaks and loose rivets/bolts/screws shall be detected and reported.

Inspections shall be so extensive that maintenance needs over and above those described in the tender documents are identified and necessary measures with associated quantities described in inspection reports.

Any further measures shall be clarified with the Project Owner and carried out, in the form of supplementary work if there are no appropriate unit prices in the contract.
 - x) Quantity shall be measured as inspected steel area. Unit: m²

- 88.421 Inspection of steel surfaces**
a) Comprises inspection of steel surfaces.
x) As in Specification 88.42. Unit: m²
- 88.422 Inspection of steel railings**
a) Comprises inspection of steel railings.
x) Quantity shall be measured as inspected railing length. Unit: m
- 88.423 Inspection of steel details**
a) Comprises inspection of steel details such as bearings etc.
x) Quantity shall be measured as number of inspected steel details. Unit: pcs
- 88.424 Chemical analysis of surface treatment**
a) Comprises sampling and chemical analysis of surface treatment.
c) Chemical analysis of surface treatment shall be carried out to clarify type of existing surface treatment and overpaintability of the existing surface treatment by the new one.
x) Quantity shall be measured as number of measurements. Unit: pcs
- 88.43 Maintenance of steel**
a) Comprises maintenance of structural components of steel
Surface treatment is included in Specification 88.48.
b-e) As in Specifications 85.1, 85.2, 85.4 and 85.5.
Before welding onto steel in the existing load-bearing structure takes place, the weldability of the steel shall be tested and a welding procedure set up especially to avoid shrink forces and risk of fatigue.
x) Costs shall be given as a lump sum. Unit: LS
- 88.431 Straightening of members, beams etc.**
a) Comprises straightening of members, beams etc.
c) As in Specification 85.221 and *the special specifications*.
x) Costs shall be given as a lump sum. Unit: LS
- 88.432 Welding of cracks**
a) Comprises welding of parts that have developed fractures or cracked welded joints.
b-e) Cracks shall be stopped by drilling out the root of the crack.
See also Specification 85.24 and *the special specifications*.
x) Quantity shall be measured as linear metres of welding. Unit: m
- 88.433 Screwing on of couplers**
a) Comprises screwing on of couplers in connection with reinforcement or cracks/fractures in the material.
b-e) As in Specification 85.25 and *the special specifications*.
x) Costs shall be given as a lump sum. Unit: LS
- 88.434 Grinding**
a) Comprises grinding of steel surfaces with hardening zones or delaminations.
c) As in Specification 85.221 and *the special specifications*.
x) Quantity shall be measured as ground area. Unit: m²
- 88.435 Rounding off of sharp edges**
a) Comprises rounding off of sharp edges.
c) As in Specification 85.221 and *the special specifications*.
x) Quantity shall be measured as length of rounded off sharp edges. Unit: m
- 88.436 Drilling of drainage holes**
a) Comprises drilling of drainage holes in areas with standing water. Grinding of hole edges is included. Repair of damage to the corrosion protection is included in Specification 88.48.

- c) Drainage holes shall not be made anywhere before the Project Owner has given his consent. Diameter shall be specified in *the special specifications*. Holes must not have dimensions or be located such that load-bearing capacity is reduced. The holes shall be located such that there is no standing water at junctions.

Drilled holes shall be ground to even the edges.

See also Specification 85.221 and *the special specifications*.

- x) Quantity shall be measured as number of holes drilled. Unit: pcs

88.437 Cathodic protection

- a) Comprises cathodic protection of steel in soils and/or in seawater.

The following work operations are included with cathodic protection unless otherwise indicated in *the special specifications*:

- Detail engineering
- Continuity and short-circuiting inspection
- Commissioning and final documentation
- Operation and maintenance

Delivery and installation of cables, instrumentation, anode system, T/L unit and control and monitoring system are included in Specification 88.7611.

- b-c) See *the special specifications*.

- x) Quantity shall be measured as area of protected surface. Unit: m²

88.44 Replacement of steel

- a) Comprises all materials, work and equipment for replacing steel.

- b-e) For delivery of materials, see Specifications 85.11, 85.13, 85.2, 85.221, 85.24 and 85.25. See also the special works specification.

- x) Quantities shall be measured as net weights according to final bills of materials. The density of steel is assumed to be 7.85 kg/dm³. Unit: ton

88.45 Maintenance of connectors

- a) Comprises replacement of rivets and tightening/replacement of screws and nuts with washers in friction and shear connections.

- c) Rivets/screws in connections between load-bearing elements shall only be removed one at a time, and a new one shall be inserted and tightened before the next rivet/screw is loosened.

Undamaged screws in shear connections can be tightened. Defective or damaged screws shall be replaced with new ones.

New friction screws with associated nuts with washers shall be used in friction connections. This also applies to loose screws.

Before new friction screws are installed, the surfaces on which the washers are to be placed shall be plane and at right angles to the screw holes. All paint and surface corrosion shall be removed from the contact surface and from the inside of screw holes.

Rivets shall be replaced with friction screws with associated nuts with washers. When rivets are replaced, the old rivets shall be replaced by drilling them out without widening the rivet hole, and a new screw adapted to the rivet hole shall be used.

See also Specifications 85.13 and 85.25 and *the special specifications*.

- x) Costs shall be given as number of screws/rivets replaced. Unit: pcs

88.451 Replacement of rivets

- a) Replacement of rivets is included in the specification.

- x) As in Specification 88.45. Unit: pcs

88.452 Tightening of screws in shear connections

- a) Tightening of screws/nuts in shear connections is included in the specification.

- x) As in Specification 88.45. Unit: pcs

88.453 Replacement of screws in shear connections

- a) Replacement of screws/nuts in shear connections is included in the specification.

- x) As in Specification 88.45. Unit: pcs

88.454 Replacement of screws in friction connections

- a) Replacement of screws/nuts with washers in friction connections is included in the specification.
- x) As in Specification 88.45. Unit: pcs

88.46 Maintenance of bridge cables

- a) Comprises maintenance and replacement of load-bearing cables with fasteners on cable-stayed and suspension bridges.
- b-e) As in Specification 85.6, Specification 85.7 and *the special specifications*.
- x) Costs shall be given as a lump sum. Unit: LS

88.47 Maintenance of hangers

- a) Comprises maintenance and replacement of hangers with upper and lower hanger attachments.
- b-e) As in Specifications 85.6 and 85.7 and *the special specifications*.
- x) Quantity shall be measured as number of repaired hangers. Unit: pcs

88.48 Surface treatment of steel

- a) Comprises maintenance and replacement of corrosion-protection coating on steel. Includes collection and transport of waste to approved special waste depots.
- b) The following section contains a description of the maintenance and replacement of the existing corrosion-protection system.

Choice of corrosion-protection system

Maintenance of duplex system

For maintenance of a "duplex system" consisting of a cathodic protection metallic coating plus paint, System 1 is used: metallisation plus epoxy/polyurethane (duplex system) as described in Specification 85.3. A full system is applied to pretreated bare steel, and epoxy mastic and polyurethane when a top coat is renewed. Zinc-enriched primer as described in Maintenance System 2 and an epoxy polyamide tie-coat sealer shall be applied to damage with a cleaned area of less than 50x50 mm. The same painting system shall then be applied as on the rest of the structure.

Maintenance of painting system

Maintenance System 1 or 2 shall be used, depending on which system has been used on the structure, for maintenance of a corrosion-protection coating that is not designed as a duplex system. A full system shall be applied to pretreated bare steel, and epoxy mastic and polyurethane when a top coat is renewed.

When completely replacing existing corrosion proofing, it must be decided whether a duplex system should be used or simply a new painting system in the form of Maintenance System 1 or 2.

Maintenance of hot dip galvanizing

Maintenance system 3 is used for minor damage to hot dip galvanizing. A corrosion-protection system must be considered in the case of major damage in particular, and shall be described in *the special specifications*. It is particularly important to ensure adhesion when painting hot-dip galvanized surfaces.

Requirements regarding corrosion-protection systems

With the exception of Maintenance System 3, each coat shall have a different colour. The colour code of the last coat shall be indicated in *the special specifications*.

The various paint products in Maintenance system 1 and any additives, thinners etc. to be used shall be obtained from the same supplier unless otherwise indicated in *the special specifications*.

For Maintenance system 2, epoxy polyamide tie-coat sealer and other paint products and any additives, thinners etc. used in the zinc-rich primer shall be from the same supplier.

The contractor shall specify supplier and paint system. The supplier shall deliver technical data sheets containing the following information:

- Pretreatment requirements
- Volume% solid matter
- % by weight of zinc in dry film (zinc-rich epoxy primer)
- Wet/dry film thickness (max./min. specified)
- Overpainting intervals at 5, 10 and 23°C (max., min.)
- Recommended thinner (quantity and type)
- Theoretical coverability
- Recommendation/requirements concerning application

All paint products and solvents shall be stored in their original packaging and shall bear the supplier's guidelines. The manufacturing number and use-by date shall be shown on all containers.

Corrosion protection system

Unless otherwise indicated in *the special specifications*, maintenance of corrosion protection consisting purely of a paint systems shall be carried out with one of the following systems.

Maintenance system 1: Zinc-rich epoxy primer (at least 90% by weight of zinc in the dry film) plus epoxy/polyurethane

Pretreatment (minimum requirements to be satisfied):

- Removal of flaking paint and corrosion products
 - Degreasing with appropriate cleaning agent and hosing with clean freshwater
 - Blast cleaning:
- Cleanliness: Sa 2.5
 Roughness: Medium G, Ry5 = 50-85 µm
 Coating system:

1. 40-75 µm zinc-rich epoxy primer
2. Min. 125 µm epoxy mastic
3. 60-100 µm polyurethane or polyurethane acryl

The thickness of the first and the last coat shall be chosen in accordance with the manufacturer's instructions for the paint type in question (see technical data sheet).

Total coating thickness: Minimum 225 µm

All thicknesses stated are dry film thicknesses.

The following general requirements are made with respect to Maintenance system 1:

1. Coating systems shall be prequalified in accordance with ISO 20340 Procedure A and shall be qualified in accordance with NORSOK M-501 "System no. 1"
2. Zinc-rich epoxy primer shall have at least 90% by weight of zinc in the dry film.
3. It shall be documented that zinc-rich primer is capable of providing cathodic protection of the sub-grade over time.

Prequalification test methods (Maintenance system 1):

Table 88.48-1	
Test	Acceptance criteria
ISO 20340	Acceptance criteria specified in ISO 20340 apply. Also applicable: Adhesion over 5 MPa before testing and less than 50% reduction after testing (NS-EN ISO 4624) Chalking: Rating 2 or less (NS-EN ISO 4628-6) Overpaintable with top coat after testing without mechanical working of surface. Adhesion at least 5 MPa (NS-EN ISO 4624)

In addition to prequalification, documentation is required of considerable experience with the coating system with respect to corrosion protection effect, general degradation and over-paintability in repeated maintenance rounds.

Maintenance system 2: Zinc-rich primer (at least 95% by weight of zinc in the dry film) plus epoxy/polyurethane

Pretreatment (minimum requirements to be satisfied):

- Removal of flaking paint and corrosion products
- Degreasing with appropriate cleaning agent and hosing with clean freshwater
- Blast cleaning: Cleaness: Sa 2.5 Roughness: Medium G, Ry5 = 50-85 µm

Coating system:

1. 50-60 µm zinc-rich primer
2. 25-30 µm epoxy tie-coat sealer
3. Min. 125 µm epoxy mastic
4. 60-100 µm polyurethane or polyurethane acryl

The thickness of the first and the last coats shall be chosen in accordance with the manufacturer's instructions for the paint type in question (see technical data sheet).

Total coating thickness: Minimum 260 µm

All thicknesses stated are dry film thicknesses.

The following general requirements are made with respect to Maintenance system 2:

1. Zinc-rich primer shall have at least 95% by weight of zinc in the dry film.
2. Epoxy tie-coat sealer shall satisfy the requirements in Specification 85.3.
3. Epoxy mastic and polyurethane or polyurethane-acrylic shall satisfy the general requirements made of Maintenance system 1.

Maintenance system 3: Zinc-rich primer (at least 95% by weight of zinc in the dry film)

Pretreatment (minimum requirements to be satisfied):

- Removal of flaking paint and corrosion products
- Degreasing with appropriate cleaning agent and hosing with clean freshwater
- Blast cleaning:

Cleanliness: Sa 2.5

Roughness: medium G, Ry5 = 50-75 µm

Coating system:

1. 50-60 µm zinc-rich primer
2. 50-60 µm zinc-rich primer
3. 50-60 µm zinc-rich primer

Total coating thickness: Minimum 150 µm

All thicknesses stated are dry film thicknesses.

The following requirements are made with respect to Maintenance system 3:

1. Zinc-rich primer shall have at least 95% by weight of zinc in the dry film.

c) **Pretreatment**

Flaking paint and corrosion products shall be removed from all surfaces that are to be treated. Degreasing shall then take place with the aid of an alkaline cleaning agent and hosing with clean freshwater.

Spinning compound shall be completely removed from the surface of hangers and cables.

In connection with partial replacement of the coating system and complete renewal of top coat, degraded paint can be removed with cautious high-pressure hosing or light sand-blasting if underlying coats can be exposed without damage due to the treatment.

All types of pre-treatment of remaining corrosion-protection coats that are to be overpainted shall be carried out cautiously to avoid damage. Transitions between bare steel and intact corrosion protection shall be gradual, and shall be built up as described in Specification 85.3.

All blast cleaning waste shall be collected, delivered and deposited at approved sites.

The cleaning method must be determined through procedure tests. If the salt content of the steel surface after blast cleaning is too high, it must be washed again and blast cleaning carried out until the specified cleanliness is achieved (Sa 2.5 for paint system and Sa 3 for duplex system).

Application

Zinc-rich primer shall be applied only to bare, blast-cleaned steel. If necessary, masking shall be used to prevent overpainting of existing coats with zinc-rich primer. The prescribed system shall then be applied to all surfaces.

For each coat that is applied, edges, corners, angles, rivet and screw heads etc. shall be stripe-coated before spray-painting.

The stripe-coating shall dry for the same length of time as that stipulated in the supplier's instructions for spray-painting.

Special work procedures shall be drawn up for narrow gaps that are difficult to access, to ensure as good a result as possible.

In other respects, as in Specification 85.3 and *the special specifications*.

- e) Inspection Class 2 according to Specification 85.3 shall be used unless otherwise indicated in *the special specifications*. In other respects as in Specification 85.3.
- x) Quantity shall be measured as total surface of steel components. The surface shall be calculated without deductions for holes and without supplements for screws, fillers etc. The surface of suspension cables and hangers shall be calculated on the basis of the theoretical diameter without supplements for grooves between individual strands. Unit: m²

88.481 Qualification of work procedures

- a) Comprises qualification of work procedures before the work starts.
- c) The procedure tests shall preferably be carried out on test plates with a minimum size of 0.5 m² or, according to agreement with the Project Owner, on the bridge structure. Procedure tests to determine the need for extra washing or blast cleaning to remove salt shall be carried out on the bridge structure. If several systems or methods of application are used, at least one test shall be made of each system and method of application.

All work procedures shall be carried out in situ, and at least one test shall be carried out for each system and method of application before the painting work starts, and then one monthly for the duration of the contract. Procedure tests shall also be carried out in the event of nonconformities and if climatic conditions or the likes change substantially.

Works that typically demand procedure tests:

- Cleaning/blast cleaning
- Complete replacement of corrosion protection, spray-painting
- Complete replacement of corrosion protection, application with brush or painting glove in narrow gaps or on surfaces that cannot be sprayed
- Process between complete replacement and maintenance of existing corrosion protection

Procedure tests shall be described in *the special specifications*.

The Project Owner may require that the contractor carry out further procedure tests if the circumstances indicate they are necessary. The contractor shall have the results available for the Project Owner at all times.

- e) As in Specification 85.31.
- x) Quantity shall be measured as number of procedure tests. Unit: pcs

88.482 Washing and degreasing

- a) Comprises cleaning of steel surface to remove oil, grease, salts etc. and hosing with clean freshwater.
- b-c) As in Specification 85.32.
- x) As in Specification 88.48. Unit: m²

88.483 Removal of degraded paint coating

- a) Comprises removal of broken down paint with cautious high-pressure hosing or light blast cleaning.
- c) Pressure, quantity of water and distance between nozzle and object shall be optimized to yield the best possible result.

High-pressure hosing shall be carried out in such a way that paint with poor adhesion is removed and intact paint remains in place.

High-pressure hosing must be carried out in such a way that as little water as possible is forced into cavities and gaps.

- x) As in Specification 88.48. Unit: m²

88.484 Grinding

- a) Comprises grinding with sandpaper or a grinding wheel on intact existing paint or hot galvanizing.
- c) Grinding shall be sufficient to satisfy all adhesion requirements and at the same time so gentle that existing coatings are preserved as well as possible.
- x) As in Specification 88.48. Unit: m²

88.485 Blast cleaning

- a) Comprises removal of corrosion-protection coating and cleaning of steel surface. The specification also covers local grinding of existing coating to prevent sharp transitions to bare, cleaned steel or exposed underlying layers of corrosion-protection coating.
- b-c) Unless otherwise indicated in *the special specifications*, blast cleaning shall be used for cleaning.

If the level of salt after the first round of degreasing, washing and blast cleaning is too high, operations must be repeated until cleanness requirements are satisfied.

In other respects, as in Specification 85.33 and *the special specifications*.

- x) As in Specification 88.48. Unit: m²

88.4851 Blast cleaning to Sa 2.5

- a) Comprises blast cleaning to Sa 2.5 and grinding of transitions before application of Maintenance System 1, 2 or 3.
- x) As in Specification 88.48. Unit: m²

88.4852 Blast cleaning to Sa 3

- a) Comprises blast cleaning to Sa 3 and grinding of transitions before metallizing with thermal spray zinc.
- x) As in Specification 88.48. Unit: m²

- 88.4853 Supplement for repeated washing and blast cleaning**
- a) Comprises supplement for repeated washing and blast cleaning to Sa 2.5 due to too high salt content.
 - x) As in Specification 88.48. Unit: m²
- 88.4854 Supplement for repeated washing and blast cleaning**
- a) Comprises supplement for repeated washing and blast cleaning to Sa 3 due to too high salt content.
 - x) As in Specification 88.48. Unit: m²
- 88.486 Metallizing**
- a) Comprises thermal spraying with zinc and hot-dip galvanizing.
 - b-e) As in Specifications 85.341 and 85.342 and *the special specifications*.
 - x) As in Specification 88.48. Unit: m²
- 88.4861 Metallizing with thermal spray zinc**
- a) Comprises thermal spraying with zinc.
 - b-e) As in Specification 85.341 and *the special specifications*.
 - x) As in Specification 88.48. Unit: m²
- 88.4862 Metallizing by hot-dip galvanizing**
- a) Comprises hot-dip galvanizing (dipping in molten zinc).
 - b-e) As in Specification 85.342 and *the special specifications*.
 - x) As in Specification 88.48. Unit: m²
- 88.487 Application of paint/organic coatings**
- a) Comprises application of paint/organic coatings.
 - b-e) As in Specification 85.35.
 - x) As in Specification 88.48. Unit: m²
- 88.4871 Zinc-rich epoxy primer**
- a) Comprises application of zinc-rich epoxy primer (at least 90% by weight of zinc in the dry film).
 - x) As in Specification 88.48. Unit: m²
- 88.4872 Zinc primer**
- a) Comprises application of zinc-rich primer (at least 95% by weight of zinc in the dry film).
 - x) As in Specification 88.48. Unit: m²
- 88.4873 Sealer /tie-coat**
- a) Comprises application of sealer/tie-coat on zinc-rich primer in Maintenance System 2 and thermally sprayed zinc to protect and fill the pores in the subgrade before applying epoxy mastic and polyurethane.
 - x) As in Specification 88.48. Unit: m²
- 88.4874 Epoxy mastic**
- a) Comprises application of epoxy mastic.
 - x) As in Specification 88.48. Unit: m²
- 88.4875 Polyurethane/polyurethane acryl**
- a) Comprises application of polyurethane or polyurethane acryl.
 - x) As in Specification 88.48. Unit: m²
- 88.5 Timber, stone and aluminium work**
- a) Comprises maintenance of timber, stone and aluminium.
 - b-e) See Specifications 86.1, 86.2, 86.3 and current Norwegian standards for timber and aluminium structures.
See also the special works specification.
 - x) Costs shall be given as a lump sum unless otherwise indicated in *the special specifications*. Unit: LS
- 88.51 Rigging, scaffolding and protection**
- a-x) As in Specification 88.31. Costs shall be given as a lump sum. Unit: LS

88.52 Wood maintenance

- a) Comprises maintenance of timber with connectors. The collection and deposition of removed materials, off-cuts etc. at approved special waste sites forms part of the specification.

Maintenance of timber surface course forms part of Specification 88.68.

- b-e) Impregnated timber shall be used. The type of pressure-impregnation and class shall be specified in *the special specifications*.
Steel components shall as a minimum be hot-dip galvanized according to Specification 85.342. See also *the special specifications*.

- x) Quantity shall be measured as planned volume of timber. Unit: m³

88.521 Removal and deposition of timber

- a) Comprises removal and deposition of timber

- b-d) A demolition plan shall be prepared that safeguards the load-bearing capacity of the structure when wood in load-bearing structures is to be replaced. All demolished timber shall be collected and deposited at approved special waste sites.

See also *the special specifications*.

- x) As in Specification 88.52. Unit: m³

88.522 Replacement of timber

- a) Comprises replacement of timber and connectors as specified in *the special specifications*.

- b-d) As in Specifications 86.11, 86.111, 86.112, 86.113, 86.12, 86.13 and 86.14.

See also *the special specifications*.

- x) As in Specification 88.52. Unit: m³.

88.523 Inspection and post-tensioning stress-laminated decks

- a) Comprises inspection and post-tensioning of stress-laminated decks as specified in *the special specifications*.

- b-d) As in Specification 86.1441. See also *the special specifications*.

- x) Quantity shall be measured as number of inspected and post-tensioned stays. Unit: pcs

88.53 Protection of timber structures

- a) Comprises surface treatment and structural protection with fittings. Cleaning, pretreatment and treatment with fungicides are included in the specification.

- b) Surface treatment shall be oil-based in accordance with Specification 86.132 and *the special specifications*. Surface treatment systems shall be built up of layers and layer thicknesses according to supplier's recommendations and adapted to the maintenance to be carried out.

Fittings with fasteners shall be as specified in Specification 86.1341.

Supplier's instructions shall form the basis for pretreatment and application of each coat. The products used for painting over existing impregnation or surface treatment must be compatible with the latter.

- c) The base shall be washed/degreased with an alkaline cleaning agent and flushed clean with water to remove fungus, grease, soot and dirt. The pressure used must not be so high that the wood splinters. All flaking existing paint shall be removed by scraping or grinding and transitions shall be established with grinding down to existing intact surface treatment. If stipulated in *the special specifications*, fungicide shall be applied.

Application of wood oil, creosote or other types of materials and stains that soak into the woodwork shall take place at least twice and any surplus oil etc. shall be removed afterwards.

When a film-forming surface treatment is used, a primer must be applied to bare wood and at least two coats of surface treatment applied.

See also the supplier's instructions and *the special specifications*.

Structural protection shall be carried out as described in Specification 86.1341 and *the special specifications*.

- x) Quantity shall be measured as protected surface. Unit: m²

88.531 Cleaning by means of washing and degreasing

- a) Comprises cleaning and removal of fungus from wooden surfaces.

- x) Quantity shall be measured as cleaned area. Unit: m²

- 88.532 Pretreatment**
- a) Comprises pretreatment with wire brushing, grinding and scraping to remove degraded wood and existing surface treatment with poor adhesion and to establish transitions to intact surface treatment that is not to be removed.
 - x) Quantity shall be measured as pretreated area. Unit: m²
- 88.533 Fungicide**
- a) Comprises cleaning and removal of fungus from wooden surfaces.
 - x) Quantity shall be measured as treated area. Unit: m²
- 88.534 Priming**
- a) Comprises priming of bare wood.
 - x) Quantity shall be measured as treated area. Unit: m²
- 88.535 Film-forming coating**
- a) Comprises surface treatment with film-forming coating on primed wood and existing surface treatment.
 - x) Quantity shall be measured as fully treated area with the stipulated number of coats. Unit: m²
- 88.536 Impregnation**
- a) Comprises surface treatment with preserving agent on bare and previously impregnated wood.
 - x) Quantity shall be measured as fully treated area with the stipulated number of coats. Unit: m²
- 88.537 Stain**
- a) Comprises surface treatment with stain on bare and previously impregnated or stained wood.
 - x) Quantity shall be measured as fully treated area with the stipulated number of coats. Unit: m²
- 88.538 Structural protection with fittings**
- a) Comprises maintenance, delivery, assembly and replacement of structural protection with fittings.
 - x) Quantity shall be measured as fitted area. Unit: m²
- 88.54 Maintenance of stone**
- a) Comprises maintenance of stone
 - b-e) As in Specification 86.24 and *the special specifications*.
 - x) Costs shall be given as a lump sum. Unit: LS
- 88.541 Filling joints in stone walls**
- a) Comprises filling of joints in stone walls
 - b) Joint-filler mortar is used with a quality as specified in *the special specifications*.
 - c) In areas where old joint mortar has fallen out or been damaged, it shall be replaced.
See also *the special specifications*.
 - x) Quantity shall be measured as linear metres of repaired joints. Unit: m.
- 88.542 Injection of stone walls**
- a) Comprises injection of stone walls
 - b) Injection grouting materials with a grade as specified in *the special specifications* shall be used.
 - c) Injection grouting shall not be carried out before the necessary anchoring has taken place. In injection work, the injection pressure must be closely monitored so that slides do not occur.
See also *the special specifications*.
 - x) Costs shall be given as a lump sum. Unit: LS
- 88.543 Anchoring of stone walls**
- a) Comprises anchoring of stone in stone walls.
 - b) Anchoring rods shall be used and if relevant other material with a grade as specified in *the special specifications*.
 - c) Well anchored and corrosion-protected anchoring rods shall be used to prevent bulges and sliding. Steel components shall as a minimum be hot-dip galvanized according to Specification 85.342.
See also *the special specifications*.

- x) Costs shall be given as a lump sum. Unit: LS

88.544 Masonry

- a) Comprises laying and replacement of stones in stone walls. The specification comprises delivery of new stone for supplementing and removal and dumping of surplus existing stone. Joint-filling is included in Specification 88.541. Membrane is included in Specification 88.6 and earthworks in Specification 88.2.
- b-e) See *the special specifications*.
- x) Quantity shall be measured as laid volume. Unit: m³.

88.55 Maintenance of aluminium

- a) Comprises maintenance and replacement of structural elements of aluminium.
- b-e) See *the special specifications*.
- x) Costs shall be given as a lump sum. Unit: LS

88.56 Surface treatment of aluminium

- a) Comprises maintenance and replacement of coatings on aluminium. Collection and deposition of waste at approved sites is included in the specification.
- b-c) As in Specification 88.48 and *the special specifications*.
- x) As in Specification 88.48. Unit: m²

88.6 Waterproofing and surface course work

- a) Comprises maintenance, replacement and re-laying of waterproofing on bridge decks and culverts, asphalt and other types of surface course, including connections.

All measures to satisfy traffic flow requirements are included in the specification.

Maintenance, replacement and re-laying crack inducing joints, asphalt joints and expansion-joint nosings are included in the specification.

If specified in *the special specifications*, cover with drying or heating, and protection of materials used against harmful effects during the curing period and until protective layers are applied shall be included, so that the specification can be carried out under controlled conditions, for example in winter.

Pretreatment of the subgrade forms part of the specification.

Earthworks that are necessary for the execution of maintenance work shall be included in Specification 88.2. Maintenance of the subgrade before paving takes place is included in Specifications 88.3, 88.4 and 88.5.
- b-e) See Specification 87.1, Handbook 018 Road construction, and the applicable contractual basis for asphaltting work for the Norwegian Public Roads Administration.

The work shall be planned and executed so as to satisfy traffic flow requirements. See *the special specifications* for choice of materials and methods.
- x) Quantity shall be measured as weight of material used. Unit: ton

88.61 Rigging, protection and temporary cover

- a) Comprises rigging, protection/cover and temporary cover for the execution of waterproofing and surface course works.
- c) As in Specification 88.31.
- x) Costs shall be given as a lump sum. Unit: LS

88.611 Rigging

- a) Comprises rigging for the execution of waterproofing and surface course work.
- x) Costs shall be given as a lump sum. Unit: LS

88.612 Protection

- a) Comprises protection/cover for carrying out waterproofing and surface course work.
- x) Costs shall be given as a lump sum. Unit: LS

88.613 Temporary cover

- a) Comprises temporary cover and air conditioning with demisting and heating, and protection of materials used against harmful effects during the curing period and until protective layers are applied so that the specification can be carried out under controlled conditions.
- b-c) As in Specification 87.11 and *the special specifications*.

- x) Quantity shall be measured as temporary covered and air-conditioned area. Unit: m²

88.62 Grinding, milling and removal of waterproofing and surface course

- a) Comprises grinding, milling and removal of waterproofing, levelling layers, binder course and surface courses of asphalt, concrete, reinforced concrete and timber. Collection and deposition at approved sites form part of the specification.

Any dismantling and re-erection of rails on parapets to permit access to a kerbing/edge beam shall form part of the specification. Moreover, all necessary adaptation and special work in connection with removal against water outlets and joint structures etc. are included.

Damage to the load-bearing structure as a result of accidental grinding, milling or removal shall be repaired by the contractor to the same standard as before the work started without cost to the Project Owner.

If Specification 88.624 is not used, all necessary sawing in connection with step-by-step execution because of traffic flow requirements shall be included.

- c) Milling equipment shall be adequately dimensioned for this type of work, and have the stability and adjustability necessary to meet the specified evenness requirements for the upper face without damage to the underlying bridge deck.

On concrete surface courses that are only to be levelled and not protected with waterproofing or concrete topping, only grinding as specified in Specification 88.621 is permitted.

Before grinding/milling, the contractor shall document that the structure can be subjected to the milling stress imposed by the equipment in question. The documentation shall be submitted to the Project Owner for verification.

The concrete cover shall be recorded before and after grinding or milling. A check shall be carried out of how much concrete is milled away, either by measuring the concrete cover or by level control.

The minimum cover after grinding/milling of a monolithic concrete surface course is set at 10 mm above the structural concrete.

Unless otherwise specified, the maximum milling depth in each pass shall not exceed 10 mm.

When removing a concrete topped surface course or pavement right down to the upper face of structural concrete in connection with replacement or re-laying of waterproofing, the contractor must take into consideration when choosing equipment and approach that, depending on the type of bridge and earlier work, the upper face of the structural concrete may be very uneven, and that the reinforcement cover in the structural concrete will vary substantially compared with theoretical reinforcement cover. Unless otherwise indicated in *the special specifications*, the contractor shall assume that the construction joint between structural concrete and concrete surface course, or the transition between structural concrete and an added layer, will be very uneven.

Unless otherwise indicated in *the special specifications*, topping shall be removed in their entirety down to the construction joint with the structural concrete. The contractor must use the combination of equipment and methods that makes this possible without the structural concrete being damaged in any way.

When topping on a concrete surface course is removed, extensive use of chipping equipment must be expected, and that the construction joint against the structural concrete must be exposed in its entirety by means of chipping.

When an asphalt layer is removed, the use of specially adapted light milling equipment and manual work to expose the upper edge of the structural concrete must be expected. When milling asphalt on bridges with a steel deck, milling equipment that has a measuring unit that continuously measures and regulates the distance to the steel deck must be used. The distance shall be measured continuously at a minimum of 2 points in the section. This is to ensure that milling takes place to the correct depth.

When milling or removing, kerbing or edge beams shall be exposed carefully so that they are not damaged. The same applies to guardrail posts, water outlets and joint structures.

Equipment and the use of equipment shall result in a surface that is appropriate for a new layer or traffic and in compliance with *the special specifications*.

If waterproofing is to be laid, the surface shall be as even as possible and without deep grooves. After the work has been completed, the structure shall be cleaned of all loose material.

- d) The fully treated surface shall not have surface defects larger than those specified in *the special specifications*.

- x) Quantity shall be measured as weight of ground/milled/removed material. Unit: ton

88.621 Grinding of concrete surface course

- a) Comprises grinding of concrete surface course to a specified level.

- b-e) As in Specification 84.67 and *the special specifications*.

- x) Quantity shall be measured as ground area. Unit: m²

- 88.622 Milling and removal of concrete surface course**
- a) Comprises milling and removal of concrete surface course to an extent specified in *the special specifications*.
 - b-e) See *the special specifications*.
 - x) As in Specification 88.62. Unit: ton
- 88.6221 Milling of monolithic cast concrete surface course**
- a) Comprises milling of concrete surface course to an extent specified in *the special specifications*.
 - b-e) See *the special specifications*.
 - x) As in Specification 88.62. Unit: ton
- 88.6222 Milling of topped concrete surface course**
- a) Comprises milling of topped concrete surface course to an extent specified in *the special specifications*.
 - b-e) See *the special specifications*.
 - x) As in Specification 88.62. Unit: ton
- 88.6223 Removal of topped concrete surface course**
- a) Comprises removal of topped concrete surface course down to structural concrete.
 - b-e) See *the special specifications*.
 - x) As in Specification 88.62. Unit: ton
- 88.623 Milling and removal of asphalt layer**
- a) Comprises milling or removal of waterproofing, levelling layer, binder course and surface course of asphalt.
 - b-e) See *the special specifications*.
 - x) As in Specification 88.62. Unit: ton
- 88.6231 Milling of asphalt on concrete decks**
- a) Comprises milling of asphalt to specified level on concrete bridge decks before re-asphalting.
 - b-e) See *the special specifications*.
 - x) As in Specification 88.62. Unit: ton
- 88.6232 Milling of asphalt on steel decks**
- a) Comprises milling of asphalt to specified level on steel bridge decks before re-asphalting.
 - b-e) See *the special specifications*.
 - x) As in Specification 88.62. Unit: ton
- 88.6233 Milling of asphalt on timber decks**
- a) Comprises milling of asphalt to specified level on timber bridge decks before re-asphalting.
 - b-e) See *the special specifications*.
 - x) As in Specification 88.62. Unit: ton
- 88.6234 Milling of asphalt on other types of bridge decks**
- a) Comprises milling of asphalt to a given level on bridge decks of aluminium, stone arch bridges, fill structures etc., before re-asphalting.
 - b-e) See *the special specifications*.
 - x) As in Specification 88.62. Unit: ton
- 88.6235 Removal of asphalt pavement on concrete decks**
- a) Comprises removal of all waterproofing, levelling layer, binder course and surface course down to the upper edge of the concrete bridge deck in connection with the installation of waterproofing or full replacement of the pavement.
 - b-e) See *the special specifications*.
 - x) As in Specification 88.62. Unit: ton

88.6236 Removal of asphalt layer on steel decks

- a) Comprises removal of all waterproofing, levelling layer, binder course and surface course down to the upper edge of the steel bridge deck in connection with the installation of waterproofing or full replacement of the pavement.
- b-e) See *the special specifications*.
- x) As in Specification 88.62. Unit: ton

88.6237 Removal of asphalt layer on timber decks

- a) Comprises removal of all waterproofing, levelling layer, binder course and surface course down to the upper edge of the timber bridge deck in connection with the installation of waterproofing or full replacement of the pavement.
- b-e) See *the special specifications*.
- x) As in Specification 88.62. Unit: ton

88.6238 Removal of asphalt on other types of bridge decks

- a) Comprises milling of asphalt to a given level on bridge decks of aluminium, stone arch bridges, culverts etc., before re-asphalting. Earthworks are included in Specification 88.2.
- b-e) See *the special specifications*.
- x) As in Specification 88.62. Unit: ton

88.624 Sawing

- a) Comprises sawing of grooves in the longitudinal direction of the bridge when removing concrete surface courses and pavement in stages because of traffic flow requirements.
- c) The cut depth shall be set so that structural concrete and load-bearing reinforcement are not sawn.
- e) There must be constant monitoring of the cut depth of sawing to ensure that the cut does not damage structural concrete or load-bearing reinforcement.
- x) Quantity shall be measured as length of sawn section. Unit: m.

88.63 Groove filling/patching of surface course

- a) Comprises groove filling or patching of surface courses of asphalt or concrete. The specification also includes cleaning of the subgrade.
- b-e) For cleaning, see Specifications 84.62 and 84.63. See also *the special specifications*.
- x) Quantity shall be measured as weight of groove-filling material used. Unit: ton

88.64 Waterproofing

- a) Comprises maintenance, replacement and re-laying of waterproofing on old bridges.

The specification includes pretreatment with sand-blasting or a similar method and cleaning of the subgrade before application, drying and if necessary heating.
- b-e) If driving has taken place directly on the top face of the bridge deck over a period of time, oil, grease and other contaminants that may result in reduced adhesion must be removed by washing with acid or a similar method. This must be done before pretreatment of the subgrade.

Pretreatment of the subgrade shall not be carried out before all repairs have been made to the concrete and adequate strength has been achieved. When pre-treating repaired surfaces, any wax-based curing compound or other type of curing compound that results in reduced adhesion between waterproofing and concrete deck shall be removed.

In other respects as in Specifications 84.62 and 84.63 for concrete, Specification 85.37 for steel, Specification 86.145 for timber and *the special specifications*.
- x) Quantity shall be measured as area with waterproofing. An area of less than 1 m² shall be counted as 1 m². Unit: m²

88.641 Simplified waterproofing

- a) Comprises simplified waterproofing type A2-1 or A2-2.
- b-e) As in Specification 87.13.
- x) As in Specification 88.64. Unit: m²

88.6411 Simplified waterproofing type A2-1

- a) Comprises simplified waterproofing type A2-1 with low viscosity epoxy.
- x) As in Specification 88.64. Unit: m²

- 88.6412 Simplified waterproofing type A2-2**
- a) Comprises simplified waterproofing type A2-2 with polymer-modified bitumen emulsion PmBE60 (C60BP3).
 - x) As in Specification 88.64. Unit: m²
- 88.642 Full waterproofing**
- a) Comprises full waterproofing type A3-1, A3-2, A3-3 or A3-4.
 - b-e) As in Specification 87.14.
 - x) As in Specification 88.64. Unit: m²
- 88.6241 Full waterproofing type A3-1**
- a) Comprises full waterproofing type A3-1 with epoxy and insulating cast asphalt.
 - x) As in Specification 88.64. Unit: m²
- 88.6422 Full waterproofing type A3-2**
- a) Comprises full waterproofing type A3-2 with prefabricated membrane.
 - x) As in Specification 88.64. Unit: m²
- 88.6423 Full waterproofing type A3-3**
- a) Comprises full waterproofing type A3-3 with polyurethane membrane.
 - x) As in Specification 88.64. Unit: m²
- 88.6424 Full waterproofing type A3-4**
- a) Comprises full waterproofing type A3-4 with PmB-based materials.
 - x) As in Specification 88.64. Unit: m²
- 88.6425 Membrane above groundwater level on structures in embankments**
- a) Comprises membrane above groundwater level on structures in embankments.
 - b-e) As in Specification 87.145 and *the special specifications*.
 - x) Quantity shall be measured as planned area. Unit: m²
- 88.6426 Membrane below groundwater level on structures in embankments**
- a) Comprises membrane below groundwater level on structures in embankments.
 - b-e) As in Specification 87.146 and *the special specifications*.
 - x) Quantity shall be measured as planned area. Unit: m²
- 88.643 Combined waterproofing/surface course**
- a) Comprises maintenance, replacement and re-laying of combined waterproofing and surface course.
 - b-e) As in Specification 87.13, 87.14 and 87.15 and *the special specifications*.
 - x) As in Specification 88.64. Unit: m²
- 88.6431 Combined waterproofing/surface course type C1**
- a) Comprises laying of combined waterproofing/surface course type C1 with PmBE60 (C60BP3) and Topeka 4S strewn with chippings.
 - b-c) Maximum thickness of combined waterproofing/surface course type C1 shall be indicated in *the special specifications*.
 Mass temperature shall be 180-190°C, but shall never exceed 200°C to avoid damaging the properties of the binding agent.
 Deck and air temperature shall be above +10°C when the operation takes place.
On bridges with a concrete deck:
 Tack coat shall be applied to mechanically pretreated and cleaned surface in a quantity of 0.3-0.5 kg/m². Tack coat shall be immediately strewn with fine sand 0.5/1.5 mm in a quantity of 1-2 kg/m². If the concrete appears open/porous, a layer of PmBE60 (C60BP3) shall be added in a quantity of 0.3-0.4 kg/m² and immediately strewn with fine sand of a similar type and quantity.
 There must be no untreated patches and/or pools.
 Once the surface is dry (3-24 hours) surplus sand shall be removed with compressed air.

On bridges with steel decks:

On steel decks the quantity of PmBE60 (C60BP3) tack coat shall be reduced to 0.1-0.15 kg/m². In other respects as for concrete decks.

On bridges that tolerate a maximum of 50 kg/m² surface course:

A 15-20 mm thick layer of waterproofing/surface course of Topeka 45 shall be laid mechanically on a fully prepared, dry and cleaned deck. After the layer has cooled, it shall be strewn with pre-coated chippings 4/8 or 8/11 mm in a quantity of 3-5 kg/m². The binding agent content shall be 11.5-12%.

On bridges that tolerate a maximum of 75 kg/m² surface course:

A 20-30 mm thick layer of waterproofing/surface course of Top8/Top 11 or Sta8/Sta11 with modified binding agent shall be mechanically laid on a fully prepared, dry and cleaned deck. After the layer has cooled, it shall be strewn with pre-coated chippings 4/8 or 8/11 mm in a quantity of 3-5 kg/m². The thickness of the placed material shall be at least 2.5 times the upper nominal stone size in the pre-coated chippings.

- x) As in Specification 88.64. Unit: m²

88.6432 Thin surface course and friction surfaces

- a) Comprises friction surfaces and thin asphalt layers with moisture-insulating properties on carriage ways and walkways.
- b-e) As in *the special specifications*. The maximum allowable weight shall be indicated. The surface shall be strewn with appropriate material in order to secure satisfactory friction.
- x) As in Specification 88.64. Unit: m²

88.65 Levelling layer, binder course and asphalt surface course

- a) Comprises maintenance, replacement and re-laying of levelling layer, binder course and asphalt surface course

Mechanical working, cleaning and sticking to the subgrade form part of the specification when the asphalt surface course is placed directly on the concrete.
- b-e) The maximum allowable weight on the surface course shall be indicated in *the special specifications*. The type of surface course and structure shall be indicated in *the special specifications*. For mechanical working, see Specifications 84.62 and 84.63.

For asphalt works, see Specification 87.15. Tack coat shall be PmBE60 (C60BP3) and meet the requirements for Specification 87.14.

Surface courses shall be laid with a slope down to drains etc. so that water does not collect in depressions etc. See also *the special specifications*.
- x) The specification shall be measured as material used. Unit: ton

88.66 Connections

- a) Comprises maintenance and establishment/replacement of special works with waterproofing and surface course at connections on the side of bridge decks and bridge ends, connections to kerbing, edge beams or concrete parapets, guardrail posts, water outlets and to asphalt decks on abutting roads and paving in parapet areas when this is not included in other specifications.
- b-e) As in Specification 87.16.
- x) Quantity shall be given as a lump sum. Unit: LS

88.661 Edges without edge beam/kerbing

- a) Comprises maintenance and establishment/replacement of edges and waterproofing/ surface course on sides of bridges without an edge beam/kerbing.

Maintenance and establishment/laying of waterproofing and surface course in the parapet area form a part of Specification 88.664.
- c) As in Specification 87.161 and *the special specifications*.
- x) Quantity shall be measured as length of edge. Unit: m

88.662 Connection with edge beam/kerbing

- a) Comprises maintenance and establishment/replacement of connection between waterproofing/surface course and kerbing or edge beams.
- c) As in Specification 87.162 and *the special specifications*.
- x) Quantity shall be measured as length of connection. Unit: m

- 88.663 Edge at bridge ends and connections in joints**
- a) Comprises maintenance and establishment/replacement of end of pavement at bridge ends, connection between pavement and joints, expansion-joint nosings, butt joints and development of wheel ruts in pavement on abutting road.
 - b-e) As in Specification 87.163 and *the special specifications*.
 - x) Quantity shall be measured as length of edge/ connection. Unit: m
- 88.6631 Edge at bridge ends**
- a) Comprises end of pavement in bridge ends with abutment-free design.
 - x) Quantity shall be measured as planned vertical area of bridge end. Unit: m²
- 88.6632 Connection with crackinducing joints**
- a) Comprises connection with crack inducing joint.
 - x) Quantity shall be measured as length of edge/connection. Unit: m
- 88.6633 Connection at asphalt joints**
- a) Comprises connection at asphalt joints.
 - x) Quantity shall be measured as length of edge/connection. Unit: m
- 88.6634 Connection with expansion-joint nosings/joint structures**
- a) Comprises connection with expansion-joint nosings/joint structures
 - x) Quantity shall be measured as length of edge/connection. Unit: m
- 88.6635 Waterproofing joints**
- a) Comprises joints between new and existing waterproofing.
 - c) Waterproofing shall be joined with an overlap over existing waterproofing.
 - x) Quantity shall be measured as length of edge/connection. Unit: m
- 88.6636 Butt joints**
- a) Comprises butt joints between new and existing surface course.
 - x) Quantity shall be measured as area of butt joints. Unit: m²
- 88.6637 Wedging out**
- a) Comprises wedging out of wheel ruts in existing surface course.
 - x) Quantity shall be measured as volume of placed wedging out. Unit: litre
- 88.664 Connection against guardrail posts and laying in parapet areas**
- a) Comprises maintenance and establishment/replacement of connection between waterproofing/surface course and guardrail posts and in parapet areas.
 - b-c) As in Specification 87.164 and *the special specifications*.
 - x) Quantity shall be measured as length of parapet areas with guardrail posts. Unit: m
- 88.6641 Laying in parapet area**
- a) Comprises laying in the parapet area.
 - x) Quantity shall be measured as planned quantity. Unit: ton
- 88.6642 Connection with guardrail posts**
- a) Comprises connection with guardrail posts.
 - x) Quantity shall be measured as number of connected guardrail posts. Unit: pcs
- 88.665 Connection with water outlets**
- a) Comprises maintenance and establishment/replacement of connection between waterproofing/surface course and water outlets.
 - b-c) As in Specification 87.165 and *the special specifications*.
 - x) Quantity shall be measured as number of connections. Unit: pcs
- 88.666 Crack inducing joint**
- a) Comprises maintenance and establishment/replacement of crack inducing joint and asphalt joint.

b-e) As in Specifications 87.17, 87.171 and *the special specifications*.

x) Quantity shall be measured as length of joint per joint type and joint size. Unit: m

88.667 Asphalt joint

a) Comprises maintenance and establishment/replacement of asphalt joint. Edges that are raised against or pass through kerbing and/or edge beam form part of the specification.

If removal and depositing of existing joint structure form part of the specification, this shall be indicated in *the special specifications*.

All concrete works form a part of Specification 88.3.

b-e) As in Specifications 87.17, 87.172 and *the special specifications*.

Dimensions and design of steel plates over joint openings and thickness and breadth of asphalt joints shall be indicated in the drawings and *the special specifications*.

Grooves for installation/passage of asphalt joints in kerbing and edge girders are restricted by saw cuts and the concrete in between removed. The bottom of the groove shall be chipped plane and pretreated with thorough sand-blasting.

Other design and erection or passage in kerbing and/or edge beam shall be indicated on the drawings and *the special specifications*.

x) Quantity shall be measured as planned volume. Unit: litre.

88.668 Expansion joint nosings

a) Comprises maintenance and establishment/replacement of expansion joint nosings.

b-e) As in Specification 87.18 and *the special specifications*.

x) Quantity shall be measured as planned volume. Unit: litre

88.67 Concrete surface course

a) Comprises maintenance, replacement and re-laying of concrete surface course, including mechanical working of subgrade before casting, gluing and other necessary pretreatment such as pre-wetting, including screeding, finishing and curing in connection with casting works.

Minor maintenance such as mechanical repair of local damage and grouting of fissures/cracks in concrete surface course form part of Specification 88.3 with underlying specifications.

Repair of structural concrete before surface wearing course work forms part of Specification 88.32 with underlying specifications.

b-e) The maximum allowable weight shall be indicated in *the special specifications*.

For mechanical treatment of existing subgrade, see Specifications 84.62 and 84.63.

For gluing, see Specifications 84.81, 84.811 and 84.82.

For screeding and treatment of concrete surface course, see Specification 84.522.

Surface courses shall be laid with a slope down to drains etc. so that water does not collect in depressions etc. For curing measures, see Specification 84.546.

See also *the special specifications*.

x) Quantity shall be measured as cast concrete volume. Unit: m³

88.68 Timber surface course

a) Comprises maintenance and replacement of timber surface course.

Maintenance and replacement of strew wood form part of Specification 88.522.

b-e) Unless otherwise indicated in the special working specifications, spruce wood with strength class C24 shall be used, with the same dimensions and design as the old surface course. Connectors shall be of the same type, dimensions and execution as existing connectors.

See also Specifications 86.146, 86.147 and *the special specifications*.

x) Quantity shall be measured as volume of timber used. Unit: m³

88.7 Equipment

a) Comprises maintenance, replacement and installation of new equipment for bridges and ferry terminals.

b-e) See *the special specifications*.

- x) Costs shall be given as a lump sum. Unit: LS

88.71 Rigging and scaffolding

- a-e) As in Specification 88.31.

- x) Costs shall be given as a lump sum. Unit: LS

88.72 Maintenance, replacement and reinstallation of parapets

- a) Comprises maintenance, replacement and reinstallation of all types of parapets of steel, wood or aluminium, protective parapets with a screen over an electrified railway, road safety barriers and transitions to road safety barriers and noise barriers.

Removal and depositing of existing parapets, and any temporary parapets form part of the specification.

Surveying and detailed design form part of the specification.

Maintenance of corrosion protection on existing parapets in connection with installation work form part of the specification. General maintenance of surface treatment forms part of Specification 88.48.

Concrete work in connection with maintenance of base plate grouting and casting of parapet recesses forms part of the specification.

Other maintenance of concrete around parapet installation points and concrete parapets forms part of Specifications 88.32 and 88.37.

- b) Drill holes and other minor damage to corrosion-protective coatings after other working of existing steel parapets shall be protected against corrosion with Maintenance System 3 according to Specification 88.48.

When components are replaced, new components shall have the same dimensions and quality as original components unless otherwise indicated in *the special specifications*. Maintenance of type-approved parapets shall be carried out with original components from the supplier who has had the parapets approved.

Tack coat anchors shall be appropriate for injection grouting of steel in concrete. (Expansion bolts may not be used). See also Specification 87.2 and *the special specifications*.

- c) **Removal of existing parapets**
Unless otherwise indicated in *the special specifications*, bolts or posts shall be cut off plane with the upper face of the concrete surface.

Inspection, surveying and detailed design

Inspection, surveying and detailed design shall be based on the tender documents, drawings and currently applicable rules and regulations.

Inspection shall identify complete needs for maintenance of existing parapets. Inspection, coupled with surveying to supplement the drawing basis, shall be so detailed that the contractor can plan procurement and execution in detail. Guardrail posts with plastic deformations or reduced capacity shall be replaced. Rails, panels, hand and foot rails can be straightened after pre-heating and maintained so that capacity is satisfactory, or be replaced.

A report in which measures and quantities are specified shall be drawn up. This shall be submitted to the Project Owner for comment before work starts.

In other respects as in Specification 87.2.

Posts in the ground

As in Specification 87.2.

Installation of guardrail posts

As in Specification 87.2.

The tensile capacity of the tack coat anchors shall be as indicated in *the special specifications*.

Templates shall be used for drilling holes for bolt groups. When drilling through, it is necessary to proceed cautiously at the end to avoid concrete being shattered on the lower face.

Before gluing, drilled holes shall be blown clean.

When fixing in place with throughgoing holes, the gap between hole and threadbar shall be grouted if the base plate is not grouted.

- d) As in Specification 87.2.

- e) The capacity of the tack coat anchors shall be tested. Before the parapets are installed, four tack coat anchors installed in the parapet area shall be loaded with 80% of characteristic capacity. If cracks or permanent deformations are found in or around one or more of the bolts, the test shall be repeated on new bolts, after revision of the installation procedure if necessary. Bolts shall be removed after the test has been carried out if they do not have sufficient capacity and are to be used for installing parapets.

If cracks or permanent deformations are not revealed by testing, tack coat anchors for the parapets may be installed. A minimum of 2% of bolts for installation of parapets shall be tested to 80% of characteristic capacity. If a defect is found, a new bolt shall be installed, and a further 2% of the bolts tested. This shall be repeated until no defects are registered during testing.

- x) Unless otherwise indicated in *the special specifications*, quantity shall be measured as linear metres of parapet.

Lengths of less than 1 m shall be calculated as 1 m. Unit: m

88.721 Maintenance of parapets

- a) Comprises maintenance of existing parapets with grouting of base plates and cast recesses in parapet installations.
- x) As in Specification 88.72. Unit: m

88.7211 Maintenance of grouting

- a) Comprises maintenance of grouting under base plates.
- x) Quantity shall be measured as number of maintained grouts. Unit: pcs

88.7212 Maintenance of grouting

- a) Comprises maintenance of grouting of guardrail post in recess.
- x) Quantity shall be measured as number of maintained groutings. Unit: pcs

88.7213 Straightening of profiles

- a) Comprises straightening of profiles in steel and aluminium parapets with plastic deformations.
- b-e) Guardrail posts with plastic deformations shall not be straightened, but replaced. Before straightening, steel shall be pre-heated.
- x) Quantity shall be measured as number of straightened profiles. Unit: pcs

88.7214 Tightening of screws

- a) Comprises tightening of screws/nuts as part of the specification.
- x) Costs shall be given as number of screws. Unit: pcs

88.722 Replacement of individual components

- a) Comprises replacement of damaged individual components of parapets.
- x) As in Specification 88.72. Unit: pcs

88.7211 Replacement of handrail

- a) Comprises replacement of handrail.
- x) As in Specification 88.72. Unit: m

88.7222 Replacement of footrail

- a) Comprises replacement of footrail.
- x) As in Specification 88.72. Unit: m

88.7223 Replacement of panel

- a) Comprises replacement of panel.
- x) As in Specification 88.72. Unit: m

88.7224 Replacement of guide rail with rear rail and block

- a) Comprises replacement of guide rail with rear rail and block.
- x) As in Specification 88.72. Unit: m

88.72241 Replacement of guide rail

- a) Comprises replacement of guide rail.
- x) As in Specification 88.72. Unit: m

88.72242 Replacement of rear rail

- a) Comprises replacement of rear rail.
- x) As in Specification 88.72. Unit: m

- 88.72243 Replacement of block**
- a) Comprises replacement of block.
 - x) Quantity shall be measured as number of replaced blocks. Unit: pcs
- 88.7225 Replacement of posts**
- a) Comprises replacement of guardrail posts and posts in protective barriers and noise barriers of steel, wood, aluminium or plastic on bridges and in transitions to road safety barriers.
 - x) Quantity shall be measured as number of replaced posts. Unit: pcs
- 88.72251 Replacement of steel guardrail post**
- a) Comprises replacement of steel guardrail post.
 - x) As in Specification 88.7225. Unit: pcs
- 88.72252 Replacement of wooden guardrail post**
- a) Comprises replacement of wooden guardrail post.
 - x) As in Specification 88.7225. Unit: pcs
- 88.72253 Replacement of aluminium guardrail post**
- a) Comprises replacement of aluminium guardrail post.
 - x) As in Specification 88.7225. Unit: pcs
- 88.72254 Replacement of plastic guardrail post**
- a) Comprises replacement of plastic guardrail post.
 - x) As in Specification 88.7225. Unit: pcs
- 88.7226 Replacement of screws and nuts including washers**
- a) Comprises replacement of screws and nuts including washers
 - c) Defective or damaged screws shall be replaced with new fitted screws or friction screws with associated nuts and washers.
- See also Specifications 85.13 and 85.25 and *the special specifications*.
- x) Quantity shall be measured as number of replaced screws. Unit: pcs
- 88.7227 Replacement of glass and panels in noise barriers**
- a) Comprises replacement of glass and panels in noise barriers.
 - x) Quantity shall be measured as number of replaced glass sheets/panels. Unit: pcs
- 88.723 Reinforcement and upgrading of existing parapets**
- a) Comprises reinforcement and upgrading of existing parapets.
 - x) As in Specification 88.72. Unit: m
- 88.7231 Reinforcement with screwed-on guide rail**
- a) Comprises reinforcement with screwed-on guide rail.
 - x) As in Specification 88.72. Unit: m
- 88.7232 Supplementing with guardrail posts in transitions to road safety barriers and end edges**
- a) Comprises supplementing with guardrail posts in transitions to road safety barriers and end edges.
 - x) Quantity shall be measured as number of posts. Unit: pcs
- 88.724 Replacement and reinstallation of parapets**
- a) Comprises replacement and reinstallation of parapets.
 - b-e) As in Specification 88.72.
 - x) As in Specification 88.72. Unit: m
- 88.7241 Detailed design**
- a) Comprises detailed design of parapets.
 - x) Quantity shall be given as a lump sum. Unit: LS

- 88.7242 Removal and depositing of existing parapets**
- a) Comprises removal and depositing of existing parapets.
 - x) As in Specification 88.72. Unit: m
- 88.7243 Delivery and erection of bridge parapets**
- a) Comprises delivery and erection of bridge parapets.
 - x) As in Specification 88.72. Unit: m
- 88.7244 Supply and erection of protective barriers over railway**
- a) Comprises delivery and erection of protective barriers over railways included in the specification.
Earthing and signposting of parapets are also included in the specification.
 - x) As in Specification 88.72. Unit: m
- 88.7245 Delivery and erection of noise barrier**
- a) Comprises delivery and erection of noise barrier.
 - x) As in Specification 88.72. Unit: m
- 88.7246 Delivery and erection of end edges**
- a) Comprises delivery and erection of end edges.
 - x) Quantity shall be measured as number of end edges. Unit: pcs
- 88.7247 Delivery and assembly of crash cushions**
- a) Comprises delivery and erection of crash cushions.
 - x) Quantity shall be measured as number of crash cushions. Unit: pcs
- 88.7248 Delivery and erection of transition to road safety barriers**
- a) Comprises delivery and erection of transition to road safety barriers with attachment to existing road safety barriers included in the specification.
 - x) Quantity shall be measured as number of transitions. Unit: pcs
- 88.73 Maintenance of bridge bearings**
- a) Comprises maintenance and replacement of bridge bearings.

Measures to prevent the structure being restrained so that jacking up cannot take place, is included in the specification. The same applies to finishing work in this connection.

Jacking and temporary support is covered by the specification. Removal and dumping of existing bearings and delivery, erection and grouting of new bearings form part of the specification.

Concreting is included in Specification 88.3 and maintenance of corrosion protection in Specification 88.48.
 - b) As in Specification 87.3 and *the special specifications*.
 - c) When making adjustments and replacements, the height and position shall be adjusted according to *the special specifications*.

Jacks shall be appropriately designed and have sufficient capacity, as specified in *the special specifications*. In connection with jacking up, jacks shall be placed and used in accordance with *the special specifications* to ensure that structural components are not damaged. All movements must be calm, without shocks or blows.

During jacking up, there must be constant monitoring to ensure that the bridge is not restrained in parapets, joint structure, support or joint openings.

Temporary bearings shall be protected against collision and possible damage in connection with the work.

After jacking up, jacks must be locked so that the overlying structure does not rest on the hydraulics.

If there is a risk of settlements in the support, settlement developments shall be monitored by taking readings, and subsequent jacking shall take place if settlement exceeds an acceptable level as indicated in *the special specifications*.

Bridge bearings shall not be loaded before the grout has achieved satisfactory strength. When replacing bearings, the supplier's instructions shall be complied with.

See also Specification 87.3 and *the special specifications*.
 - x) Quantity shall be measured as number of maintained or replaced bridge bearings. Unit: pcs

88.74 Maintenance of joint structures

- a) Comprises maintenance and replacement of joint structures, such as tightening of bolts, maintenance/replacement of worn or damaged parts, maintenance/replacement of joint components or whole joint structures.

Included in replacement are detailed engineering and delivery and installation of a complete joint structure in the specification unless otherwise indicated in *the special specifications*. End edges and passages in kerbing/edge beams and concrete parapets are included. The same applies to cleaning and/or removal of remaining old formwork and other material that may block the joint gap.

Removal and dumping of existing joint structure and concrete chippings and other waste form part of the specification.

Any dismantling/intermediate storage and re-erection of parapets is included in the specification.

When there is a need for maintenance of concrete beyond a joint bed for casting of a new joint structure with edge edges/passages, this is included in Specification 88.32.

If there is a need for drilling in and grouting in place of dowels and splicing bars, this is included in Specification 88.3245.

Work associated with waterproofing and surface courses, crack inducing joints, asphalt joints and expansion-joint nosings is included in Specification 88.6.

- b) Joint structures shall satisfy the requirements in Specification 87.4.

c) **Detailed design**

The contractor shall check the length of joints and the opening of the joint gap in situ and carry out detailed design of the selected joint structure before the joint structure is ordered.

The drawings and surveying at the bridge site shall form the starting point for the detailed design, which shall among other things ensure that the size of the joint bed, end edges and installation are adapted to the specific joint structure that is used.

Cables that may come in conflict with joint work shall be identified and safety measures necessary for avoiding damage to persons and installations shall be described.

Detailed design shall be submitted to the Project Owner for comment before the final ordering of a joint structure.

Subsidiary operations

Joint work shall be divided up into subsidiary operations so that traffic flow requirements are satisfied.

Concreting

If a need is discovered for measures beyond the work necessary to cast in place a joint structure, the Project Owner shall be notified and further work shall be agreed separately. There may, for example, be a need to rectify damage or to establish a larger joint gap so that movements can be absorbed.

Unless otherwise indicated in *the special specifications*, the contractor may choose freely among the three methods for removing concrete described in Specification 88.32.

Joint bed shall be chiselled up according to the joint supplier's specification.

The method used must not have a harmful effect on the remaining reinforcement and concrete. Existing reinforcement shall be exposed and preserved. If irregularities in relation to original design drawings are discovered, the Project Owner shall be notified immediately so that the plans can be specially adapted.

In other respects as in Specification 87.4.

Delivery and installation of joint structure

In order to achieve flexibility, extra joint components and rubber membrane length in excess of theoretical measures shall be ordered to allow for cutting of lengths etc. in a stage by stage installation.

In other respects as in Specification 87.4.

Cleaning up

Joint gap, support recess and underlying terrain shall be completely free of sand, dirt, chippings etc. when the work is completed.

Waste

All waste such as existing joints, removed asphalt and concrete shall be dumped at an officially approved landfill.

See also *the special specifications*.

- d-e) As in Specification 87.4.

- x) Quantity shall be measured as length of replaced joint structure. Unit: m

- 88.741 Joint replacement**
- a) As in Specification 88.74. End edges are included in Specifications 88.742 and 88.743, passages in Specification 87.744 and extra underlying water runoff system in Specification 88.745.
 - b-x) As in Specification 88.74. Unit: m
- 88.742 End edges in kerbing/edge beam**
- a) Comprises end edges of joint structure in kerbing/edge beam
 - x) Quantity shall be measured as number of end edges. Unit: pcs
- 88.743 End edges in concrete parapets**
- a) Comprises end edges of joint structure in concrete parapets.
 - x) Quantity shall be measured as number of end edges. Unit: pcs
- 88.744 Passage in kerbing/edge beam**
- a) Comprises passage of joint structure in kerbing/edge beam.
 - x) Quantity shall be measured as number of passages. Unit: pcs
- 88.745 Water runoff system**
- a) Comprises delivery and installation of underlying water runoff system in joint space in addition to joint structure with primary waterproofing.
Surveying and detailed design form part of the specification.
 - b-c) As in Specification 87.47.
 - x) Quantity shall be measured as length of underlying water runoff system. Unit: m
- 88.75 Maintenance of water runoff and other pipe systems**
- a) Comprises maintenance, modification and replacement of water outlets and other pipe systems. Removal and dumping of existing water outlets, concreting of holes and core drilling for new water outlets form part of the specification.
Work with waterproofing and surface courses in connection with maintenance of water outlets forms part of Specification 88.665.
 - b-c) As in Specifications 87.5, 88.32 and 88.326.
New water outlets shall be fixed properly and the passage in the bridge deck shall be waterproof.
It must be checked that water runoff is satisfactory and that water does not accumulate and remain on the bridge deck or other parts of the structure.
See also *the special specifications*.
 - x) Quantity shall be measured as number of water outlets. Unit: pcs
- 88.751 Removal of existing water outlets**
- a) Comprises removal and dumping and concreting of holes from water outlets.
 - x) Quantity shall be measured as number of removed water outlets. Unit: pcs
- 88.752 Modification of water outlets**
- a) Comprises modification of existing water outlets, for example lengthening of pipes on the lower face of the bridge deck.
 - x) Quantity shall be measured as number of modified water outlets. Unit: pcs
- 88.753 Delivery and installation of new water outlets**
- a) Comprises delivery and installation of new water outlets.
 - x) Quantity shall be measured as number of installed water outlets. Unit: pcs
- 88.76 Maintenance of electrical installations and machinery**
- a) Comprises maintenance, replacement and initial installation of electrical facilities and machinery. Inspection/service and performance testing of electrical installations and machinery is included in Specification 88.25.
 - b- c) See *the special specifications*.
 - x) Costs shall be given as a lump sum. Unit: LS

88.761 Maintenance, electrical installations

- a) Comprises detailed design, maintenance, replacement, delivery, installation and link-up of complete electrical installations on bridges and at ferry terminals.

Delivery and installation of cables, cable bridges (i.e. support for the cable duct), ducts etc, through which cables may be drawn on bridges are also included in the specification. Maintenance, delivery and installation of all electrical equipment for cathodic protection are included in the specification. Removal and dumping of outdated electrical installations are included in the specification.

Earthworks and concrete work that are necessary for the work are included in Specifications 88.2 and 88.3.

- b-e) For detailed design, electrical installations, power supply control and monitoring system, instrumentation, anode systems and final documentation for cathodic protection, see EN 12696-1.

In other respects, as in Specification 87.6 and *the special specifications*.

- x) Costs shall be given as a lump sum. Unit: LS

88.7611 Electrical installations

- a-c) Comprises maintenance, replacement, delivery and installation of a complete electrical installation for electrical and mechanical equipment on a bridge/at a ferry terminal.

On bridges, the specification comprises delivery and installation of tensioning ducts for cable ducts in bridge decks before casting work, heating cables on water outlets etc.

For ferry terminals the specification comprises maintenance, replacement, delivery and installation of complete electrical installations as described in Handbook 141 Ferjeleier-2 [Ferry terminals-2], Handbook 175 Standard ferjekaibrer [Standard ferry quay bridges] and Handbook 181 Standard ferjekaier [Standard ferry terminals].

- x) Costs shall be given as a lump sum. Unit: LS

88.7612 Lighting

- a-c) Comprises maintenance, replacement, delivery and installation of complete lighting with link-up to the power distribution panel. All costs that are not calculated into Specification 88.7611 are included in the specification.

For ferry terminals the specification comprises complete lighting as described in Handbook 141 Ferry terminals-2, Handbook 175 Standard ferry quay bridges and Handbook 181 Standard ferry quays.

- x) Costs shall be given as a lump sum. Unit: LS

88.76121 Road lighting

- a) Comprises maintenance, replacement, delivery and installation of complete road lighting, including pole with supports and armatures, and if relevant tensioning ducts, cables, couplings, fuse board etc. on bridges and at ferry terminals.

- x) Costs shall be given as a lump sum. Unit: LS

88.76122 Marking lights and warning lights

- a) Comprises maintenance, replacement, delivery and installation of marking lights and warning lights designed to warn traffic on roads, in the air and on water on bridges and at ferry terminals.

- x) Costs shall be given as a lump sum. Unit: LS

88.76123 Decorative lighting

- a) Comprises maintenance, replacement, delivery and installation of complete decorative lighting on bridges and at ferry terminals.

- x) Costs shall be given as a lump sum. Unit: LS

88.76124 Interior lighting

- a) Comprises maintenance, replacement, delivery and installation of complete interior lighting in box girders, hollow columns etc. Light switches shall be installed at all inspection hatches/doors.

- x) Costs shall be given as a lump sum. Unit: LS

88.76125 Other lighting

- a) Comprises maintenance, replacement, delivery and installation of other lighting.

- x) Costs shall be given as a lump sum. Unit: LS

88.7613 Special electrical equipment for ferry terminals

- a-c) Comprises maintenance, replacement, delivery and installation of special electrical equipment for ferry terminals as described in Handbook 141 Ferry terminals 2, Handbook 175 Standard ferry quay bridges, Handbook 181 Standard ferry terminals and *the special specifications*.

All costs that are not calculated into Specification 88.7611 are included in the specification.

- x) Costs shall be given as a lump sum. Unit: LS

88.76131 Electrical control gear for main and reserve power

- a) Comprises maintenance, replacement, delivery and installation of complete electrical control gear.
- x) Quantity shall be measured as number of control gears. Unit: pcs

88.76132 Electrical material and equipment in generator building

- a) Comprises maintenance, replacement, delivery and installation of electrical material and equipment such as cables, delivery point cabinets, switchboards, sockets, fittings etc. in the generator building.
- x) Quantity shall be measured as number of control gears. Unit: pcs

88.76133 Cable drum for emergency power

- a) Comprises maintenance, replacement, delivery and installation of cable drum.
- x) Quantity shall be measured as number of cable drums. Unit: pcs

88.7614 Power supply

- a) Comprises maintenance, replacement, delivery and installation of transformers, rectifiers, generators, solar panels, windmills, batteries etc. with cabinets, connections, cabling, tensioning ducts etc.

All costs that are not included in Specification 88.7611 are included in the specification.

- x) Quantity shall be given as a lump sum. Unit: LS

88.7615 Control and monitoring systems

- a) Comprises maintenance, replacement, delivery and installation of control and monitoring systems on bridges and at ferry terminals for ferry quay bridges and movable bridges, traffic flow, cathodic protection systems etc. and instrumentation and monitoring systems for recording weather conditions, stresses, function, condition development, alarm systems etc.

Data loggers, modems, computers, PLS, software, mobile telephones, instrumentation, sensors, cabinets, fixings, cabling, tensioning ducts etc. form part of the specification.

All costs that are not included in Specification 88.7611 are included in the specification.

- x) Quantity shall be given as a lump sum. Unit: LS

88.76151 Control systems for ferry quay bridges

- a) Comprises maintenance, replacement, delivery and installation of control systems for ferry quay bridges as described in Handbook 141 Ferry terminals 2, Handbook 175 Standard ferry quay bridges, Handbook 181 Standard ferry terminals and *the special specifications*.
- x) Costs shall be given as a lump sum. Unit: LS

88.761511 Radio control

- a) Comprises delivery and assembly of radio control of the type indicated in *the special specifications*.
- x) Quantity shall be measured as number of transmitters/receivers. Unit: pcs

88.761512 Signal lights for ferry quay bridge

- a) Comprises maintenance, replacement, delivery and installation of signal lights.
- x) Quantity shall be measured as number of signal boxes. Unit: pcs

88.761513 Automatic control of ferry quay bridge (docking)

- a) Comprises maintenance, replacement, delivery and installation of automatic control system for raising and lowering ferry quay bridge.
- x) Costs shall be given as a lump sum. Unit: LS

88.76152 Control systems for movable bridges

- a) Comprises maintenance, replacement, delivery and installation of control systems for movable bridges.
- x) Costs shall be given as a lump sum. Unit: LS

88.76153 Control and monitoring system for traffic flow

- a) Comprises maintenance, replacement, delivery and installation of control and monitoring systems for traffic flow on movable bridges, bridges that are closed in strong wind, facilities for automatic closing if hit by a ship etc.
- x) Costs shall be given as a lump sum. Unit: LS

88.76154 Control and monitoring system for cathodic protection

- a) Comprises maintenance, replacement, delivery and installation of control and monitoring systems for cathodic protection.
- x) Costs shall be given as a lump sum. Unit: LS

88.76155 Instrumentation and monitoring

- a) Comprises maintenance, replacement, delivery and installation of instrumentation and monitoring.
- x) Costs shall be given as a lump sum. Unit: LS

88.761551 Instrumentation and monitoring of weather conditions

- a) Comprises maintenance, replacement, delivery and installation of instrumentation and monitoring weather conditions.
- x) Costs shall be given as a lump sum. Unit: LS

88.761552 Instrumentation and monitoring of loads

- a) Comprises maintenance, replacement, delivery and installation of instrumentation and monitoring loads.
- x) Costs shall be given as a lump sum. Unit: LS

88.761553 Instrumentation and monitoring of function

- a) Comprises maintenance, replacement, delivery and installation of instrumentation and monitoring of function.
- x) Costs shall be given as a lump sum. Unit: LS

88.761554 Instrumentation and monitoring of condition developments

- a) Comprises maintenance, replacement, delivery and installation of instrumentation and monitoring of condition developments.
- x) Costs shall be given as a lump sum. Unit: LS

88.7616 Alarm systems

- a) Comprises maintenance, replacement, delivery and installation of alarm systems.
- x) Costs shall be given as a lump sum. Unit: LS

88.7617 Anodes for cathodic protection

- a) Comprises maintenance, replacement, delivery and installation of sacrificial anodes and anodes with impressed current for cathodic protection.

Electrical connections are included in the specification.
- x) Costs shall be given as a lump sum. Unit: LS

88.76171 Sacrificial anodes for cathodic protection

- a) Comprises maintenance, replacement, delivery and installation of sacrificial anodes for cathodic protection.

Electrical connections are included in the specification.
- x) Quantity shall be measured as number of anodes. Unit: pcs

88.76172 Anodes with impressed current

- a) Comprises maintenance, replacement, delivery and installation of anodes with impressed current for cathodic protection.

Electrical connections are included in the specification.
- x) Quantity shall be measured as cathodic protected area. Unit: m²

88.7618 Surge protection

- a) Comprises maintenance, replacement, delivery and installation of earthing, lightning conductor and other surge protection.
- x) Costs shall be given as a lump sum. Unit: LS

88.762 Maintenance of machinery

- a) Comprises detailed design, maintenance, replacement, delivery and installation of mechanical equipment. For ferry quay bridges, the specification includes complete mechanical equipment as described in Handbook 141 Ferry terminals-2, Handbook 175 Standard ferry quay bridges and Handbook 181 Standard ferry quays.

All costs for electrical work that are not included in Specification 88.7611 are included in the specification. Removal and dumping of outdated machinery with accessories are included in the specification.

b-e) As in Specification 87.7 and *the special specifications*.

x) Costs shall be given as a lump sum. Unit: LS

88.7621 Hydraulic equipment

a) Comprises maintenance, replacement, delivery and installation of hydraulic equipment for movable bridges, lifting systems for ferry quay bridges and other hydraulic equipment. The actual lift tower is included in Specification 85.

x) Costs shall be given as a lump sum. Unit: LS

88.76211 Hydraulic generator

a) Comprises maintenance, replacement, delivery and installation of hydraulic generator.

x) Quantity shall be measured as number of generators. Unit: pcs

88.76212 Hydraulic cylinders

a) Comprises maintenance, replacement, delivery and installation of hydraulic cylinders for opening or lifting and closing of movable bridges, ferry quay bridges, locking systems etc.

x) Quantity shall be measured as number of cylinders. Unit: pcs

88.76213 Hydraulic pipes and hoses

a) Comprises maintenance, replacement, delivery and installation of hydraulic pipes and hoses.

x) Costs shall be given as a lump sum. Unit: LS

88.7622 Pumps

a) Comprises detailed design, maintenance, replacement, delivery and installation of pumps.

x) Quantity shall be measured as number of pumps. Unit: pcs

88.7623 Dehumidification system

a) Comprises detailed design, maintenance, replacement, delivery and installation of dehumidification systems.

x) Quantity shall be measured as number of dehumidification systems. Unit: pcs

88.7624 Emergency power generator

a) Comprises detailed design, maintenance, replacement, delivery and installation of emergency power generators.

x) Quantity shall be measured as number of emergency power generators. Unit: pcs

88.7625 Fixed movable access equipment

a) Comprises detailed design, maintenance, replacement, delivery and installation of fixed movable access equipment such as lifts, internal inspection trolleys and painting trolleys etc. including suspension, lift cables, vertical rail system fastened to the load-bearing structure, propulsion machinery with control system etc.

Access to trolleys is included in Specification 87.772.

c) Access equipment shall be designed and installed so that rules from government authorities are complied with.

Trolleys shall be equipped with an emergency brake. Lifts shall be equipped with an emergency telephone with direct contact to a manned security centre.

See also the special works specification.

x) Costs shall be given as a lump sum. Unit: RS

88.76251 Lift

a) Comprises detailed design, maintenance, replacement, delivery and installation of lifts inside the bridge pylon etc.

x) Quantity shall be measured as number of lifts. Unit: pcs

88.76252 Inspection trolley

a) Comprises detailed design, maintenance, replacement, delivery and installation of inspection trolley inside box girders etc.

x) Costs shall be given as a lump sum. Unit: LS

88.76253 Painting trolley

- a) Comprises detailed design, maintenance, replacement, delivery and installation of painting trolleys.
- x) Costs shall be given as a lump sum. Unit: LS

88.7626 Barriers

- a) Comprises maintenance, replacement, delivery and installation of barriers.
- x) Quantity shall be measured as number of barriers. Unit: pcs

88.77 Maintenance of other equipment

- a) Comprises maintenance, replacement, delivery and installation of other equipment for bridges and ferry terminals. Removal and dumping of outdated equipment is included in the specification.
- b-e) As in Specification 87.8 and *the special specifications*.
- x) Costs shall be given as a lump sum. Unit: LS

88.771 Maintenance of vibration dampers and fendering

- a-c) Comprises maintenance, replacement, delivery and installation of vibration dampers on bridges, fenders on bridges and supplementary quays and fenders behind ferry quay bridges.
- x) Costs shall be given as a lump sum. Unit: LS

88.7711 Maintenance of vibration dampers

- a) Comprises maintenance, replacement, delivery and installation of vibration dampers.
- x) Quantity shall be measured as number of vibration dampers. Unit: pcs

88.7712 Maintenance of fenders for bridges and ferry quays

- a) Comprises maintenance, replacement, delivery and installation of fenders as collision protection against car and shipping traffic on bridges and ferry quays.

At ferry terminals the work includes:

Steel plate walls:

- Repair of cracks in welding joints and loose bolts
- Repair of damage to underlying wood

Steel pipes with car tyres:

- Repair of damage to bollards, chains and car tyres

Steel pipes with a rubber fender between pipe and quay, and screwed on plastic plank towards the ferry:

- Repair/replacement of cracked rubber fenders
- Repair/replacement of damaged or worn plastic plank
- Replacement of lorry/dumptruck tyres

Dumptruck tyres directly against concrete wall:

- Repair of damage to bollards, chains and car tyres

- b-e) See *the special specifications*.

- x) Costs shall be given as a lump sum. Unit: LS

88.7713 Maintenance of fenders for ferry quay bridge

- a) Comprises maintenance, replacement, delivery and installation of fenders for ferry quay bridges.
- x) Quantity shall be measured as number of fenders. Unit: pcs

88.772 Maintenance of fixed access equipment

- a) Comprises maintenance, replacement, delivery and installation of fixed access equipment.
Mobile access equipment such as lifts, inspection trolleys and painting trolleys form part of Specification 88.7625. See also the special works specification.
- c) As in Specification 87.83.
See also the special works specification.
- x) Costs shall be given as a lump sum.

88.773 Maintenance of buildings associated with bridges and ferry terminals

- a-c) Comprises maintenance of generator buildings, other equipment buildings, operations and service buildings, and other buildings associated with bridges and ferry terminals.
- x) Costs shall be given as a lump sum. Unit: LS

88.774 Maintenance of equipment for buildings

a-c) Comprises maintenance, replacement, delivery and installation of equipment for bridges and ferry terminals.

x) Costs shall be given as a lump sum. Unit: LS

88.775 Maintenance of decoration

a) Comprises maintenance, replacement, delivery and installation of decoration on bridges.

x) Costs shall be given as a lump sum. Unit: LS

88.776 Maintenance of special equipment for ferry terminals

a) Comprises maintenance, replacement, delivery and installation of special equipment for ferry terminals.

b-e) See *the special specifications*.

x) Costs shall be given as a lump sum. Unit: LS

88.7761 Maintenance of mooring equipment (bollards)

a) Comprises maintenance, replacement, delivery and installation of mooring equipment (bollards).

x) Quantity shall be measured as number of bollards. Unit: pcs

88.7762 Maintenance of safety equipment for quays

a) Comprises maintenance of safety equipment such as rescue ladder, lifebuoy, wooden edging etc.

x) Costs shall be given as a lump sum. Unit: LS

88.8 Available for other operations and maintenance

13 COMPONENT CODE WITH EXPLANATION

13.1 THE PLACE AND COMPONENT CODE

In large projects, a place code may be used to specify where the work is to be executed, for example different bridges, roads or tunnels. Place codes are not standardized, and can be chosen freely as needed. Examples:

BB Bråten Bridge
C02: Culvert 02
TA: Aksla Tunnel

In the case of large structures, a place code can also be used to specify parts of the structure:

BSA: Sund Bridge Viaduct Axis 1-15
BSB: Sund Bridge Main Span Axis 16-18
BSC: Sund Bridge Viaduct Axis 19-22

For work on bridges, a component code can be used instead or as well to specify a subdivision of place.

It may be relevant to use the component code in the following connections:

- editing of tender documents/process lists and follow up of contract operations (costs)
- damage sites in connection with inspections and maintenance

13.2 RELATIONSHIP BETWEEN THE COMPONENT CODE AND THE GENERAL SPECIFICATIONS

The component code is a supplement to, not a part of the General Specifications. The component code is a consequence of the editing method used in Principal Specification 8. To enable the General specifications to be used irrespective of how structures are designed, processes are largely broken down according to type of work.

A piece of work is only defined unambiguously when not only the type of work but also where in the building it is to be carried out has been specified. In connection with tendering for large structures, it will therefore be advisable to divide the structure into components.

Standardized component codes are given below. For special types of bridge, etc., where the standardized component code is not appropriate, available code numbers can be used, and the breakdown of components and the component code can be adapted to the individual facilities.

13.3 COMPLETE COMPONENT CODE FOR TENDER DOCUMENTS

A component code consists of one letter and one digit.

One or two more characters may be added as needed to distinguish components of the same type. The characters may represent an axis number, sequential number etc.

A component code must be defined for each individual project and be shown on a separate copy of the plan view, for example. The boundaries between the different elements must be fixed so that each element constitutes a natural part of the construction process.

In the editing of tender documents, the breakdown into elements should be limited to the essentials.

A0 GENERAL COSTS

- A1 Preparatory and general work
- A2 Non-bridge/quay work associated with bridges

B0 EARTHWORKS

- B 1 Construction pit
- B2 Piles
- B3 Sheet-piling
- B4 Embankments
- B5 Anchoring in soil/rock
- B6 Erosion protection
- B7 Slope protection
- B9 Other earthworks

C0 SUBSTRUCTURE

- C1 Abutments
- C2 Columns/piers
- C3 Towers
- C4 Cable anchorage
- C5 Arch abutments
- C6 Counterweight housing
- C7 pontoons
- C8 Protection against ship impact
- C9 Other substructure

D0 SUPERSTRUCTURE

- D1 Slab
- D2 Beams
- D3 Box girders
- D4 Arches
- D5 Suspension structure
- D6 Trusses
- D7 Bascule bridges
- D8 Strut frame
- D9 Other superstructure

E0 WATERPROOFING/WEARING COURSE

- E1 Waterproofing
- E2 Wearing course
- E3 Asphalt joints, expansion joint nosings etc.
- E9 Other sealing/wearing course

F0 STRUCTURES IN SOILS

- F1 Culverts
- F4 Vaulted elements
- F5 Pipe components
- F6 Trough structures
- F7 Support structure
- F8 Tunnel in soils
- F9 Other structures in soils

G0 BRIDGE ACCESSORIES

- G1 Parapets
- G2 Bearings
- G5 Expansion joints
- G6 Drainage
- G9 Other bridge accessories

H0 ELECTRICAL FACILITIES

- H1 Cables with ducts
- H2 Lighting
- H3 Heating system
- H4 Power supply
- H5 Control and monitoring system
- H6 Emergency system

- H7 Earthing system
- H8 Telecommunications equipment
- H9 Other electrical systems

I0 MECHANICAL EQUIPMENT

- I1 Hydraulic lifting equipment
- I2 Mechanical lifting equipment
- I3 Pumps
- I4 Mobile access equipment
- I5 Barriers
- I9 Other mechanical equipment

J0 SERVICE BUILDINGS AND SPECIAL EQUIPMENT

- J1 Vibration dampers
- J2 Fendering
- J3 Fixed access equipment
- J4 Equipment and service buildings
- J5 Special equipment for bridges
- J6 Special equipment for ferry terminals
- J7 Signs/information boards
- J9 Other service buildings and special equipment

K0 SPECIAL INSTALLATIONS

- K1 Drainage facility
- K2 Ventilation system
- K3 Fire extinguishing system
- K4 Dehumidification system
- K5 Anode system
- K9 Other special installations

L0 OTHER ELEMENTS

13.4 EXPANDED COMPONENT CODE

In order to record construction data and damage etc. in Brutus, an expanded standardised component code can be used using letters and more digits. The expanded component code can be found in the Brutus regulations and is not intended for use in the tender documents for new structures.

